

High Performance Product Catalog

ITECH - YOUR POWER TESTING SOLUTION



As a professional manufacturer of power testing instruments and solutions, ITECH always focus on 'customer needs' and is committed to the research of cutting edged power testing technologies. With the wide range of products including AC/DC programmable power supply, AC/DC programmable electronic load, regenerative power system, bidirectional DC power supply, battery tester/simulator, PV simulator, gird simulator, power meter, power system, etc., ITECH has created well matched testing solutions for various industry fields, such as EV, solar, energy storage, automotive electronics, semiconductor, academic research, 5G, IoT and so on.

We keep moving with the development of industries and continuous innovations. The long term cooperation with top research institutes and universities enable us to continuously improve technology and bring engineers with reliable, precise, easy operated and cost saving test instruments.

Meanwhile, we care about environment protection and sustainable development. We create power regenerative products to help reducing power consumption and carbon emission.

Until now, ITECH products has appeared in more than 50 countries and areas in the world. On the way to safer and more efficient testing, we never stop.

ITECH, your power testing solution.

■ Support and Service

ITECH has established professional technical team and complete service system to support you on the maintenance and repair, calibration, product upgrading worldwide.

■ Technical Training

ITECH provides you with professional technical training. You can start operation easily and conveniently.



This information is subject to change without notice. For more information, please contact ITECH.



ITECH

YOUR POWER TESTING SOLUTION



AC Electronic Load P05~15

DC Electronic Load P16~58

AC Power Supply P59~93

DC Power Supply P94~167

Source Measure Unit P168~175

Power Meter P177~178

Internal Resistance Tester P179~180

Test System P181~207

Accessories P208~210

Selection Guide P211~222

AC electronic load

IT8200 Regenerative AC/DC Electronic Load	P05
IT8600 AC/DC Electronic Load	P13

DC electronic load

IT-M3800 Regenerative DC Electronic load	P16
IT-M3300 Regenerative DC Electronic Load	P22
IT8000 Regenerative DC Electronic Load	P28
IT8700P+ High Speed Multi-channel DC Electronic Load	P32
IT8700P Multi-channel Programmable DC Electronic Load	P36
IT8700 Multi-channel Programmable DC Electronic Load	P40
IT8400 High performance DC electronic load	P42
IT8900A/E High Performance High Power DC Electronic Load	P48
IT8800 High Power DC Electronic Load	P52
IT8912E High Accuracy DC Electronic Load	P57

AC power supply

IT7900P High Performance Regenerative Grid Simulator	P59
IT7900 Regenerative Grid Simulator	P68
IT7800 High Power AC/DC Power Supply	P76
IT-M7700 High Performance Programmable AC Power Supply	P82
IT7600 High Power Programmable AC Power Supply	P87
IT7300 Programmable AC Power Supply	P92

DC power supply

IT-N6900 Programmable DC Power Supply	P94
IT-M3140 Programmable DC Power Supply	P96
IT-M3900B Regenerative Power System	P99
IT-M3900C Bidirectional Programmable DC Power Supply	P104
IT-M3900D High power DC Power Supply	P109
IT-M3100 Series Ultra-compact Wide Range DC Power Supply	P115
IT-M3100D Dual-channel DC Power Supply	P119
IT-M3200 Series High-precision Programmable DC Power Supply	p123
IT-M3400 Series Bidirectional DC Power Supply	P128
IT-M3600 Series Regenerative Power System	P134
IT6000B Series Regenerative Power System	P140
IT6000C Series Bidirectional Programmable DC Power Supply	P147
IT6000D Series High Power Programmable DC Power Supply	P151
IT6400 Bipolar DC Power Supply / Battery Simulator	P153
IT6500 Wide-range High-power DC Power Supply	P155
IT6900B Wide-range Programmable DC Power Supply	P159
IT6800A/B Single Channel Programmable DC Power Supply	P161



DC power supply

IT6700H High Voltage Wide Range Programmable DC Power Supply	P163
IT6100B High Accuracy Programmable DC Power Supply	P165
IT6100 High Performance Programmable DC Power Supply	P166
IT6300 High Performance Triple Channels DC Power Supply	P167

Source Measure Unit

IT2800 Graphical Source Measure Unit	P168
--	------

Power Meter

IT9100 Power Meter	P177
IT5100 Battery Internal Resistance Tester	P179

Test System

ITS5300 Battery Charge & Discharge Test System	P182
IT9380 Solar Battery Test Software	P191
Automotive Junction Box Test System	P193
SAS1000 Solar Array Simulation Software	P194
BSS2000 Battery Simulation Software	P200
FCS3000 Fuel Cell Simulation Software	P206

Accessories

Optional Accessories	P208
----------------------------	------

Selection Guide

Product Selection Guide	P211
-------------------------------	------

IT8200 Regenerative AC/DC Electronic Load

Applications

parallel RLC Circuit, V2G, EVSE, PCS, UPS.



Adopting advanced SiC technology, IT8200 Series is a regenerative programmable AC/DC electronic load. It is power regenerative, which not only saves electricity and cooling costs for you, but also good for energy saving and environmental protection. AC load mode supports both rectification and non-rectification, providing CC/CR/CP/CS/CC+CR/CE operating modes. It can simulate multiple circuit topologies under CE mode such as single-phase rectification RLC Circuit and parallel RLC Circuit. IT8200 can be applied to the test of V2G, EVSE, PCS, UPS, inverter, etc. IT8200 Series adopt a high power density design, and the power can reach 6kVA in a 2U unit and 15kVA in a 3U unit. After parallel connection, the power can be extended to 960kVA at most. Its LCD touch screen with graphical UI interface can directly define different waveforms. Combined with arbitrary waveform editing function and perfect protection function, it is an ideal choice for R&D testing and system construction.

Feature

- Adopt advanced SiC technology
- High power density, 15kVA in 3U unit
- Measure up to 16 parameters including Vrms/Arms/Freq/CF/PF/UTHD/ITHD/±Vpeak.
- Master/Slave parallel, power up to 960kVA
- High efficient energy regeneration
- Voltage - 350 VL-N
- Comprehensive working modes selectable: single-phase, three-phase, reversed phase. Rated voltage can be extended to 200% under reversed phase
- Frequency: 16-500Hz
- Support NORMAL/LIST/SWEEP/Surge&Sag modes
- Built-in various waveforms
- Touch screen, simple UI for easy operation
- Built-in USB/CAN/LAN/Digital IO interface, optional GPIB /Analog&RS232
- DC mode supports nine working modes, including CC, CR,CP, and CV
- AC mode supports CC/CP/CR/CS/CC+CR/CE multiple working modes, CE mode can simulate various circuit topologies such as single-phase rectifier RLC and parallel RLC
- AC mode supports both rectification and non-rectification modes
- Adjustable crest factor: 1.414 ~ 5.0
- Supports phase shift, ranging from -90° to 90° *1
- The unit power factor1 function allows the current waveform to vary with the voltage waveform and the power factor is as close to 1 as possible
- In three-phase AC mode, two access modes are supported: Y and Δ
- Comprehensive harmonics measurement and analysis, up to 50th.
- Built-in IEC61000-3-2/3-12 pre-compliance test standard *2
- Support the loading and unloading angle control, the full range of $0-359^\circ$ can be set
- Various protection functions such as Protect auto clear (UV&FE auto Clear), POVP, POCP, UVP, Software watchdog

* 1 After the rectification function is enabled, the setting range of phase shift is restricted by the peak factor

* 2 Voltage/current harmonic analysis, current harmonic simulation, fundamental wave $\leq 60\text{Hz}$

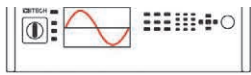

APPLICATION

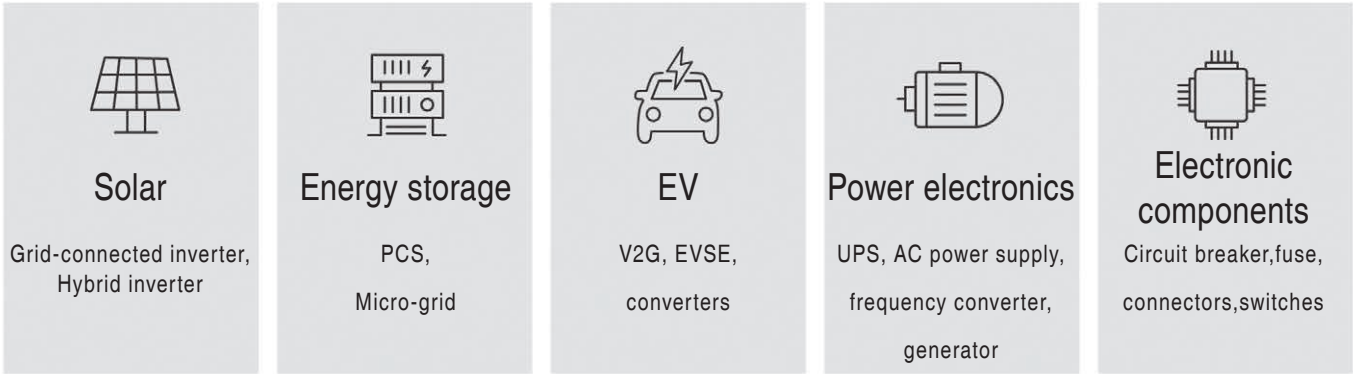

Model	Voltage	Current	Power	Phase	Phase
IT8203-350-30U	350 V	30 A	3 kVA	1Φ	3 U
IT8205-350-30U	350 V	30 A	5 kVA	1Φ	3 U
IT8206-350-90	350 V	90 A	6 kVA	1Φ or 3Φ	3 U
IT8209-350-90	350 V	90 A	9 kVA	1Φ or 3Φ	3 U
IT8212-350-90	350 V	90 A	12 kVA	1Φ or 3Φ	3 U
IT8215-350-90	350 V	90 A	15 kVA	1Φ or 3Φ	3 U
IT8230-350-180	350 V	180 A	30 kVA	1Φ or 3Φ	6 U
IT8245-350-270	350 V	270 A	45 kVA	1Φ or 3Φ	15 U
IT8260-350-360	350 V	360 A	60 kVA	1Φ or 3Φ	27 U
IT8275-350-450	350 V	450 A	75 kVA	1Φ or 3Φ	27 U
IT8290-350-540	350 V	540 A	90 kVA	1Φ or 3Φ	27 U
IT82105-350-630	350 V	630 A	105 kVA	1Φ or 3Φ	27 U
IT82120-350-720	350 V	720 A	120 kVA	1Φ or 3Φ	37 U
IT82135-350-810	350 V	810 A	135 kVA	1Φ or 3Φ	37 U
IT82150-350-900	350 V	900 A	150 kVA	1Φ or 3Φ	37 U
IT82165-350-990	350 V	990 A	165 kVA	1Φ or 3Φ	37 U

* Please contact ITECH for high power needs.
* The above specifications are subject to update without notice.

Regenerative AC/DC electronic load

The IT8200 series are new regenerative AC Electronic Load with 88% energy recovery capability. Whether in AC mode or DC mode, the power generated by the DUT can be fed back to the grid, rather than being dissipated as heat, which protects the environment and save the cost of electricity, HVAC and cooling infrastructure.

Production facility

24hours/day x 7 working days x 52 weeks



Power (kW)	Electricity saved (appr.USD/year)	CO2 emission reduced (appr.ton/year)
15	17,428	124
90	104,570	745
165	191,712	1,365
960	1,115,412	7,943

R&D lab

8hours/day x 5 working days x 52 weeks



Power (kW)	Electricity saved (appr.USD/year)	CO2 emission reduced (appr.ton/year)
15	4,368	30
90	26,208	177
165	48,048	325
960	279,552	1,891

* The data is based on :

1. approximate electricity price 0.14USD/kWh for industry facility
2. 1kWh power consumption \approx 0.997 CO2 emission

* The extra cost of air conditioning is not included.

High power density

The IT8200 series is available from 3U stand-alone to 15 U/27 U/37 U cabinets and other different compact structure design. It can meet different test requirements of users from 5k~165kVA, and the voltage output can reach 350V. The size of 3U/15 kVA model is only 1/12 of a conventional type of AC power supply, saving a lot in space and cost and providing users with a high-power test program that can be directly placed on the experimental table.

Master/slave parallel, large capacity free combination

The 3U model of IT8200 can be master-slave paralleled to reach 960kVA output at most. It can improve the output current and power capacity to meet the requirements of higher power testing. IT8200 comes with synchronous On/Off input and output signals, which ensure the synchronization of paralleling and ensures synchronous current sharing of multiple modules. After paralleling, all functions are retained and there's no loss of accuracy, making the construction of the power system faster, more flexible, and more economical, either it is a stand-alone test or ATE system.

3U

3~15kVA



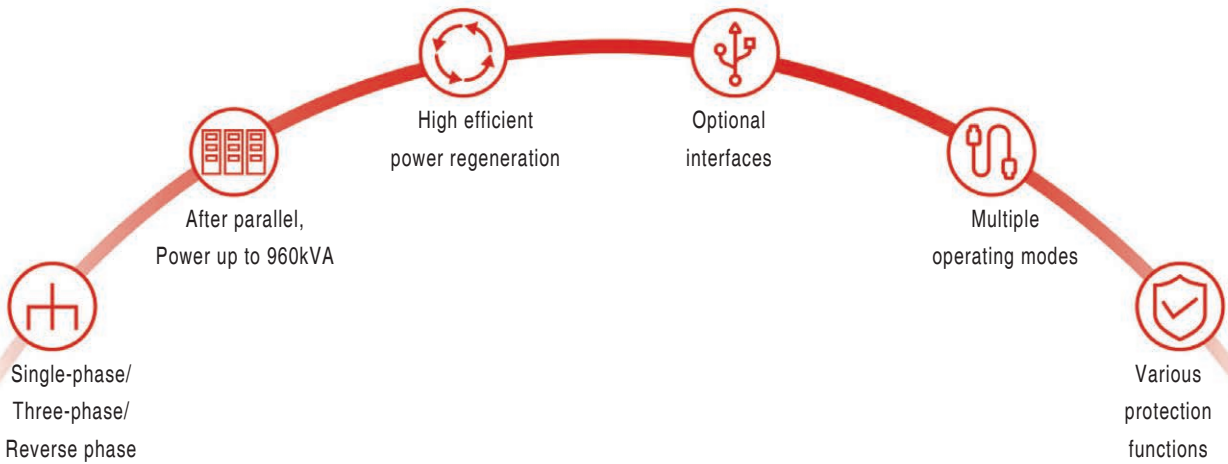

IT8200



15U	27U	37U
-----	-----	-----

Single-phase, three-phase, reverse-phase

The IT8200 series has single-phase, three-phase, and reverse-phase output modes, which can be selected through the menu. Under reverse mode, the single-phase 350V input voltage can be increased to 700V with the power down to 2/3 of the original. Under the three-phase mode, you can choose a Y-type or a Δ -type connection. The Y-type connection supports the C-phase loss.

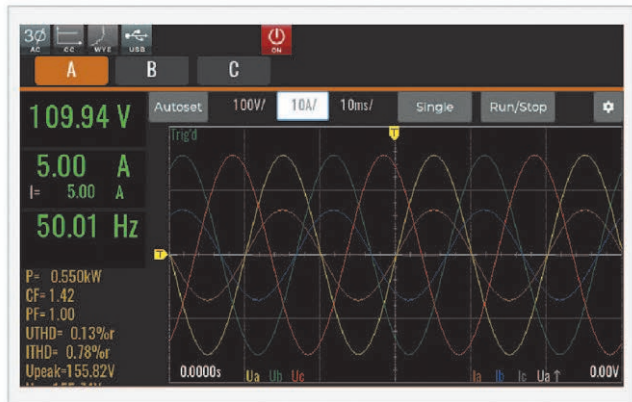

CF 1.414-5.0

The crest factor indicates the extreme peaks of the waveform. For applications that require a pure sine wave, it is desirable to have a CF value of the load current waveform of 1.414 or as close as possible. However, in practical applications, the peak shape of the current waveform of the load may become very sharp and its CF is often higher than 1.414. At this time, the starting point of the sine wave starts to shift from 0 degrees to the positive degree. So you need to correct the waveform. The Crest Factor of the IT8200 can be adjusted from 1.414 to 5.0, and it also allows to set the phase shift angle from -90° to 90° , correct the resulting amplitude, and keep the RMS unchanged. This enables more accurate simulation of field test conditions to ensure the reliability of the unit under test (UUT).

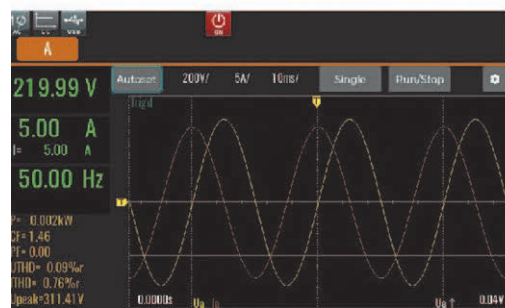
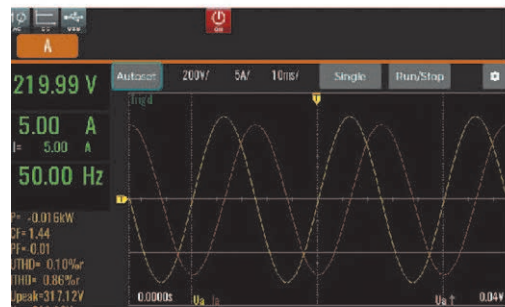
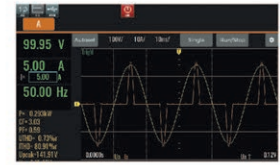
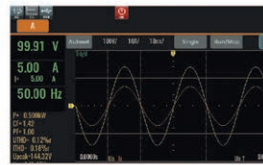
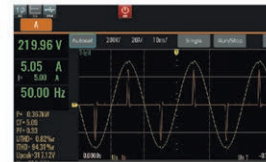



AC/DC load conditions emulation

DC load mode

- Constant Voltage (CV)
- Constant Current (CC)
- Constant Resistance (CR)
- Constant Power (CP)
- CC+CV
- CR+CV
- CP+CV
- CC+CR
- CP+CV+CR+CC

AC load mode

- Constant Current (CC)
- Constant Resistance (CR)
- Constant Power (CP)
- Constant apparent power (CS)
- CC+CR
- CE RLC

Single rectified RLC
Parallel RLC
.....

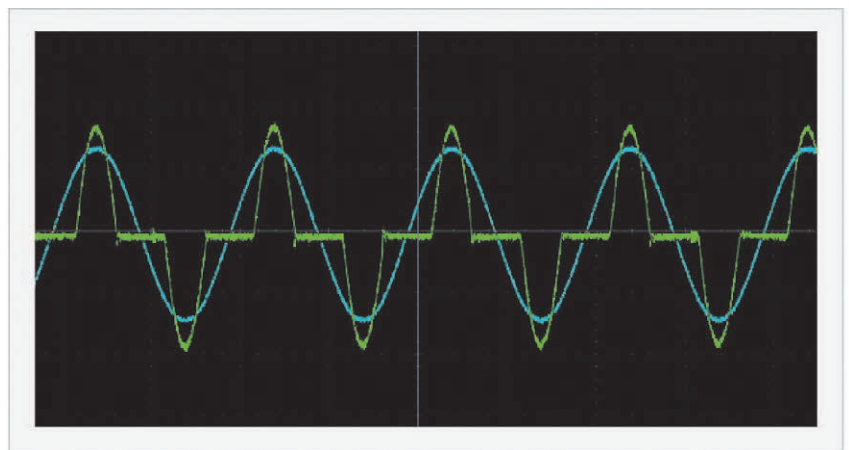
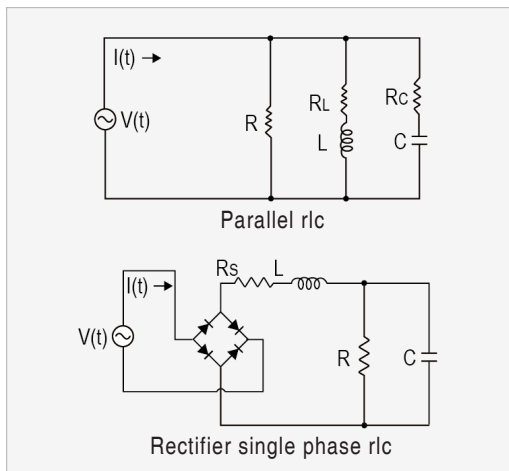

IT8200 AC electronic load can enable the 'Rectified' function in AC mode, so that the load works in the first and third quadrants to ensure that the voltage and current flow always in the same direction. At this time, full wave, positive half wave, or negative half wave can be freely selected.

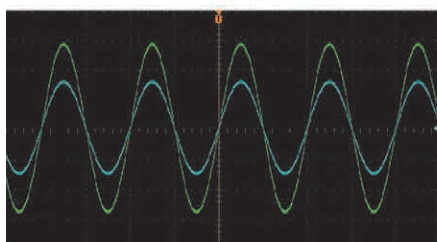

full wave

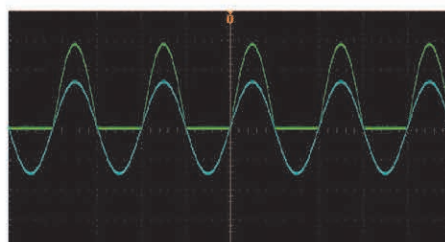

positive half wave

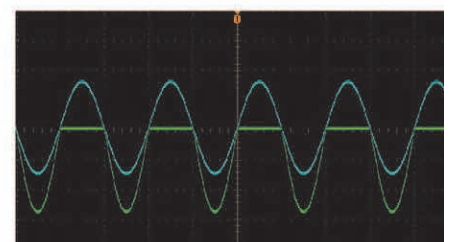

negative half wave

Waveform

Oscilloscope function

The IT8200 series has built-in digital oscilloscope functions, which can collect time domain signals of voltage and current, phase relationship, and perform waveform triggering, etc. Its sampling rate is as high as 10us, up to 6 oscilloscope curves can be displayed at the same time, and instantaneous analysis can be completed.

Further more, with its data recording function, you can observe the output for a long time, and store the obtained data to an external storage device for secondary analysis. A wide variety of test requirement can be met even without a data acquisition instrument or an oscilloscope.



Harmonic analysis

Harmonic analysis functions include both voltage and current harmonic measurement. In the harmonic mode, the voltage and current total harmonic distortion (THD) and the phase difference test of the harmonic to the fundamental wave can be realized. In addition, you can make multiple harmonic measurements. The test results are displayed in a list, histogram or vector diagram, easy to check. In the meantime, IT8200 AC electronic load also has built-in IEC 61000-3-2 / 61000-3-12 regulations, which can be recalled directly for pre-compliance testing.



Harmonic simulation

Harmonic test is one of the important test items for EMC immunity. IT8200 series has built-in 30 THD waveforms for quick recall. Thanks to the high-speed DSP technology, IT8200 series can also customize THD waveform. By setting the amplitude and phase, it can simulate up to 50th order harmonics (fundamental frequency is 50Hz or 60Hz), forming a periodic distortion waveform.



Data record

Thanks to the data record function, the IT8200 series can continuously record data for up to 7 hours at the fastest time interval of 100ms, and provides you with a 'trend' graph to check the curve of the entire test process. Up to 6 curves can be displayed simultaneously. In addition, you can also observe the precise data at a certain moment in the trend graph by sliding on the front panel. This function helps to analyze the abnormality of DUT during long-term testing, inflection point under loading, etc. Test data can be exported by a USB for further analysis.



Built-in multiple waveforms

IT8200 has built-in sine, triangle, square, trapezoidal and clipped-sine wave. These waveforms can be recalled through the menu and displayed on the screen. Further more, the complex testing requirement can be met by further editing the relevant parameters.



Intuitive software interface

IT8200 series provides free PC software PV8200 with an intuitive GUI. Meanwhile, it allows remote control, even the ATE models without display screen can be programmed, communicated and monitored.



LIST/SWEEP/Surge&Sag

IT8200 series supports NORMAL, LIST and SWEEP mode. Each mode can work with Surge&Sag function. In LIST mode, you can edit multiple steps and any waveform can be selected for each step. One List file can contain maximum 200 steps. Parameters such as frequency, amplitude, running time, and rising slope of each waveform can be edited.

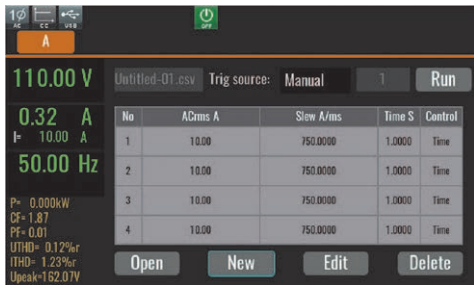

The SWEEP function helps to test the efficiency of the switching power supply in AC mode, grab the voltage and frequency of the maximum power point, and make the setting parameters change step by step.

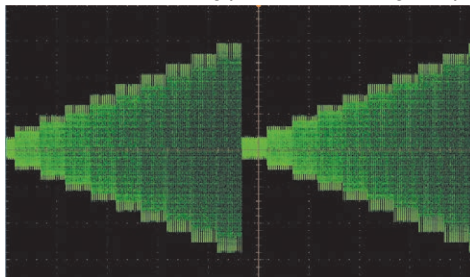

Surge&Sag works in each mode of NORMAL/LIST/SWEEP. Use trigger or cycle to control the drop of surge and sag, set the starting angle of the drop, and support waveform smoothing, symmetrical and asymmetrical waveform operations. Waveforms can be quickly created to reproduce waveform distortions or transient events such as spikes, dropouts or any other anomalies.

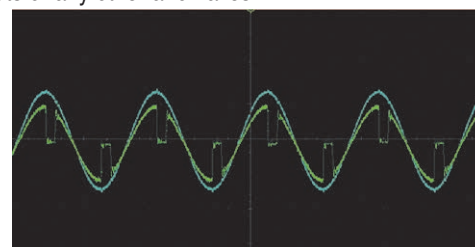
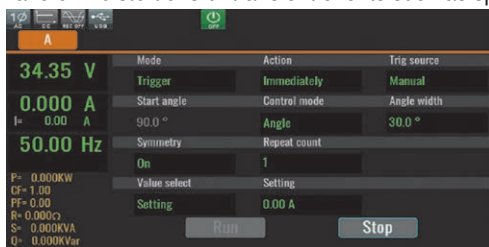

IT8600 AC/DC Electronic Load



Applications

UPS, Inverter, Frequency converter, Generator, AC power supply, Electronic component

Feature

- Frequency range: 45 Hz~450 Hz
- Power range: 0~14.4 kVA
- Voltage range: 50~420 Vrms, 15~260 Vrms
- Current range: 0~160 Arms
- Parallel connection/ 3-phase control , power can be expanded to 43.2kVA
- 7"LCD screen
- Oscilloscope function supporting display of voltage and current waveform
- High-speed AD sampling, real-time capture waveform
- Measure Vrms, Vpk, Vdc, Irms, Ipk, Idc, W, VA, VAR, CF, PF and FREQ
- Measures THD (V) up to 50th harmonic
- AC electronic load: CC/CR/CP mode
- DC electronic load: CC/CR/CP/CV mode *1
- External 0~10 V analog control input, voltage and current analog monitoring function*2
- OTP, OCP, OVP, UVP and OPP protection function
- LAN and USB communication interfaces and USB (Host) interface provides data logging functionality

*1. Only IT8615 and IT8615L have CV mode

*2. Only IT8615 and IT8615L have External analog function

*For any GPIB interface option request , check with ITECH for availability.

T8600 is ITECH latest series of AC/DC electronic loads with power range 0~14.4kVA, power can be expanded to 43.2kVA after paralleling, and adjustable frequency 45 Hz ~ 450 Hz. The unique oscilloscope waveform display function of IT8600's can display input voltage & current as waveform. It is equipped with measurement modes for different parameters such as inrush current, peak value, effective value, PF (power factor),etc. Voltage harmonic measurement capacity is up to 50th. The built-in LAN and USB communication interfaces are for reliable and fast control. IT8600 is the perfect solution for testing UPS, inverters, AC power supplies and relevant AC electronic components etc.

Application

- UPS
- Inverter
- Frequency converter
- Generator
- AC power supply
- Electronic component



Model	Voltage	Current	Power	Output
IT8615	50~420Vrms	20Arms	1800VA	1φ
IT8615L	15~260Vrms	20Arms	1800VA	1φ
IT8616	50~420Vrms	40Arms	3600VA	1φ
IT8617	50~420Vrms	60Arms	5400VA	1φ or 3φ
IT8624	50~420Vrms	80Arms	7200VA	1φ
IT8625	50~420Vrms	100Arms	9000VA	1φ
IT8626	50~420Vrms	120Arms	10.8kVA	1φ
IT8627	50~420Vrms	140Arms	12.6kVA	1φ
IT8628	50~420Vrms	160Arms	14.4kVA	1φ

Display Multiple Parameters Simultaneously

IT8600 provides 7 inch user-friendly graphical display interface. Given full consideration to engineers' requirements in different tests, IT8600 not only can display multiple parameters simultaneously, but can set as different display modes, such as waveform, histogram and list etc.



Harmonic Measuring And Analysis Function

IT8600 provides powerful data measurement function, which can not only support measurement of conventional parameters such as Vrms, Vpk, Vdc, Irms, Ipk, Idc, W, VA, VAR, CF, PF and Freq, but also provides unique voltage harmonic analysis function to verify DUT (UPS, generators, etc.). The harmonic measurement function supports analysis up to the 50th of voltage harmonic and it can display the percentage of each harmonic analysis results in different forms.

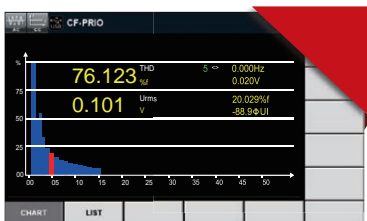

BARL

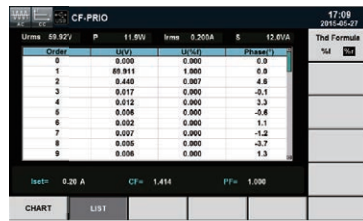

IST

Oscilloscope Function

The most unique highlight of IT8600 lies in the oscilloscope display function, which can display the input voltage and current waveform of the DUT measured. Through the screenshot function key to save the current screen picture to USB host, easy for the second analysis.

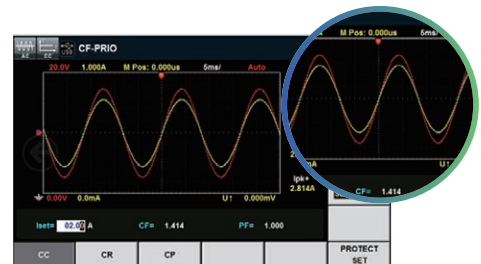

Parallel/3-Phase Control

IT8600 provides parallel and 3-phase functions for three-phase and high-power applications, power can extend up to 43.2kVA after paralleling. In 3-phase applications, users can make in star or in delta connection according to their specific requirements. IT8600 is available for AC 380V input to meet diverse test requirements.

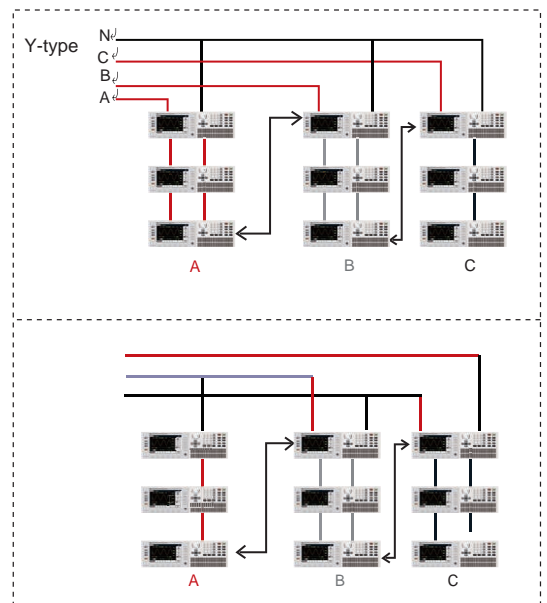

Adjustable CF/PF Value

IT8600 has CC, CR and CP operation modes. In CC and CP operation modes, PF or CF or both are available for programming. Power factor range is -1~1 lead or lag, CF setting range is 1.414~5, besides CF and PF, IT8600 also has various settings modes to realize current simulation.

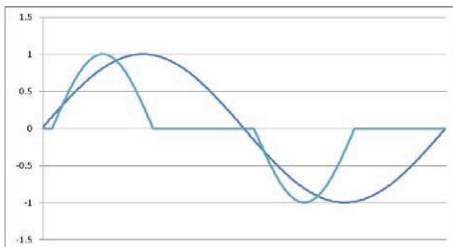

CF=2
PF=0.68

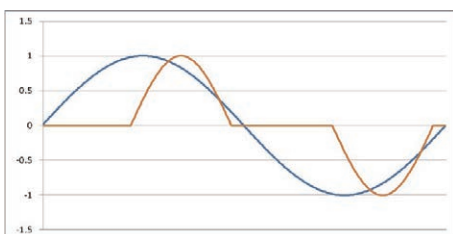

CF=2
PF=-0.68

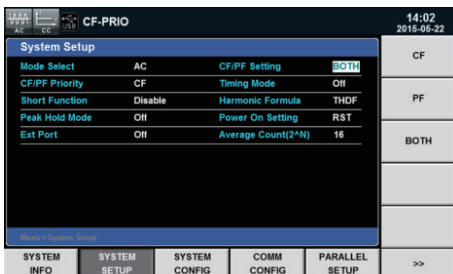

Abundant Communication Interface

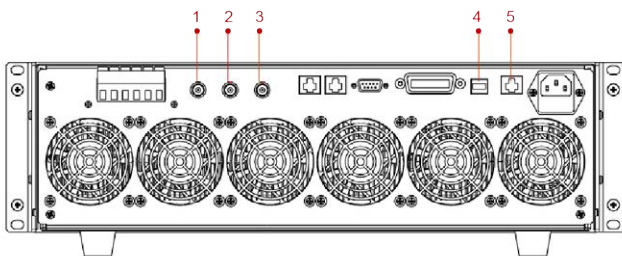

1. Analog input terminal
2. Current monitor terminal
3. Voltage monitor terminal
4. USB interface
5. LAN interface

Short circuit simulation function

IT8600 AC/DC electronic load can simulate short circuit under DC load mode.

The actual current value consumed under the short circuit state depends on the operating mode and current range of the load. Users can press [Short] soft key to switch short circuit state. The max short circuit current is 120% of current range value under CC, CP and CR mode.

In the CV mode, the short circuit means set the voltage value as 0V.*1



*1 Only IT8615 and IT8615L are with CV mode

Data Logging Function

IT8600 series AC/DC electronic load can record all the data in the measurement process, users can press [Log] key to set the time interval for recording, and press the [Start] key to start recording data, the current measured data is recorded from time to time, the data is saved to the USB host.

e.g. IT8615.csv

I/V Monitor

IT8600 AC/DC electronic load has I/V monitor and allows users to observe current and DUT output voltage through connecting to oscilloscope by BNC. The function is very useful for users to monitor the change of voltage and current by waveforms. Not only simplify the wiring, improve the measurement accuracy, but also save test cost without oscilloscope current probe.

IT-M3800 Regenerative DC electronic load

5G Communications & Data Centre

Industrial component

Photovoltaic Energy Storage

Aging



The IT-M3900 product family includes four series : DC power supply, bidirectional power supply, regenerative power system and regenerative DC electronic load. It keeps the consistent high power density design of the M series. In a 1U unit, the power can reach up to 6kW, the current can reach 510A, and the voltage is up to 1500V, which greatly saves your room. Rich models and powerful functions allow you to complete various complex tests with confidence. IT-M3800 series regenerative DC electronic load can not only perform as a DC load, but also feed back power to the grid, which saves electricity and cooling costs for you. It can complete high-precision output and measurement, and supports multiple protection functions. It is well applied to the test of 5G communication and data center, industrial components test, aging test, PV and energy storage test, power optimizer and other fields.

Feature

- Compact design, 1U@6kW, 2U@12kW
- Voltage range: 10~1500V
- Current range: 8A~720A
- Power range: 12kW
- Master/slave parallel connection keep good performance while power extension*1
- Efficient power regeneration - reduce cost of electricity and cooling
- Slope of voltage, current and power is settable
- Battery discharge test
- Short-circuit simulation
- List function, max.200 steps
- 8 operation modes under Source mode CC/CV/CW/CP/
- CC+CV/CV+CR/CR+CC/CC+CV+CW+CR
- Von function - On/Off control
- Multiple protection: OVP / ±OCP / ±OPP / OTP /voltage transient drop protection/anti-islanding
- Power grid automatic detection
- Pre-charge to prevent current overshoot
- Built-in USB/CAN/LAN/digital IO interfaces, Optional GPIB/ Analog&RS232

*1 If 1U models>16, 2U models>8, pls. contact ITECH

	Model	Current	Power	Size
10V	IT-M3801-10-120	3~120A	12~1200W	1U
	IT-M3802-10-240	4~240A	40~2400W	1U
	IT-M3803-10-360	6~360A	60~3600W	1U
	IT-M3807-10-720	12~720A	120~7200W	2U

	Model	Current	Power	Size
32V	IT-M3802-32-80	80A	2kW	1U
	IT-M3804-32-160	160A	4kW	1U
	IT-M3806-32-240	240A	6kW	1U
	IT-M3812-32-480	480A	12kW	2U

	Model	Current	Power	Size
80V	IT-M3802-80-40	40A	2kW	1U
	IT-M3804-80-80	80A	4kW	1U
	IT-M3806-80-120	120A	6kW	1U
	IT-M3812-80-240	240A	12kW	2U

	Model	Current	Power	Size
300V	IT-M3802-300-20	20A	2kW	1U
	IT-M3804-300-40	40A	4kW	1U
	IT-M3806-300-60	60A	6kW	1U
	IT-M3812-300-120	120A	12kW	2U

	Model	Current	Power	Size
500V	IT-M3802-500-12	12A	2kW	1U
	IT-M3804-500-24	24A	4kW	1U
	IT-M3806-500-36	36A	6kW	1U
	IT-M3812-500-72	72A	12kW	2U

	Model	Current	Power	Size
800V	IT-M3802-800-8	8A	2kW	1U
	IT-M3804-800-16	16A	4kW	1U
	IT-M3806-800-24	24A	6kW	1U
	IT-M3812-800-48	48A	12kW	2U

	Model	Current	Power	Size
1500V	IT-M3806-1500-12	12A	6kW	1U

Application

5G Communications & Data Centre

Server power supply, HVDC power supply
48V rack power supply



Industrial component

Fuse, automotive connector, current sensor



Photovoltaic Energy Storage

MPPT DC-DC power supply, power optimizer

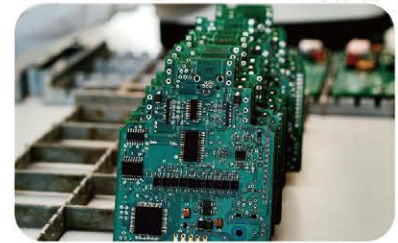

Aging

Power module, wiring harness



High power density, compact size design

ITECH has been adhering to the high power density design to help customers optimize test solutions. IT-M3800 series provide up to 6kW power in 1U chassis, and up to 12kW power in 2U chassis. ITECH entire high power density product line is more complete and comprehensive.

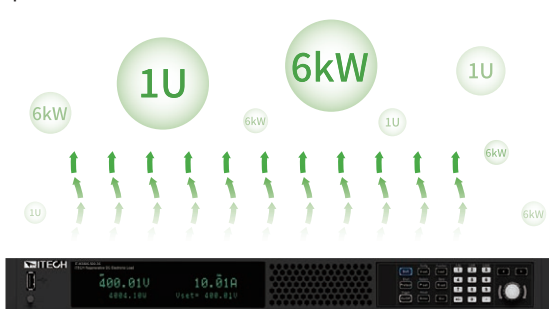

Volume reduced by 3/4



ITECH

VS

6kW solution

4U

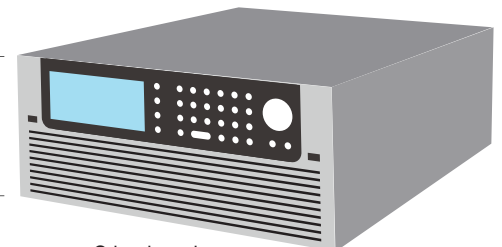

Other brands

Wide range design, save your purchasing cost

The IT-M3800 series has 25 models, with voltage from 10V~1500V and current up to 720 A. The wide range design provides users with more voltage and current combinations than the traditional fixed range DC loads, making it more flexible. A single unit can cover a wide range of applications, significantly reducing the complexity of system building and saving room.

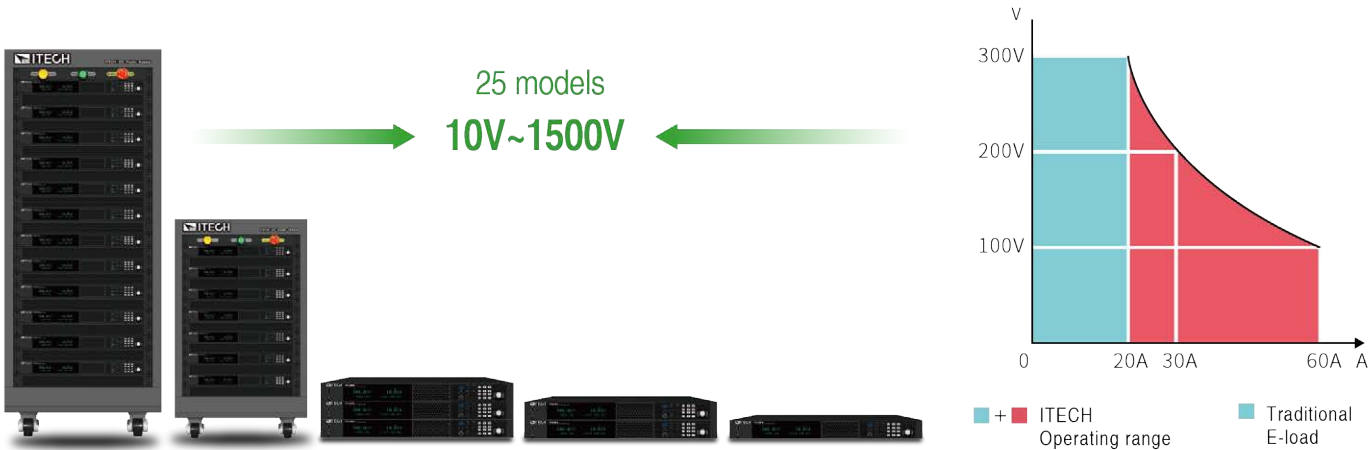

Power regenerative and eco-friendly

With the power regeneration function, IT-M3800 can feed back up to 95% power instead of consuming it as heat. It not only save your cost of electricity, HVAC and cooling infrastructure, but also help to reduce carbon emission and impact on the environment. In addition, IT-M3800 has the function of automatic grid detection, which can detect phase voltage and frequency in real time and synchronizes with the grid to make energy regeneration automatic and safe.

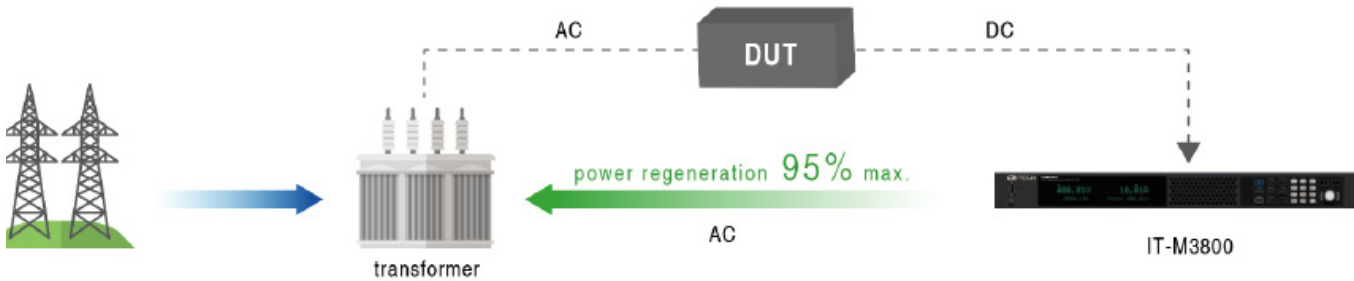

Production facility : 24Hr/day x 7 work days x 52 weeks

Power	Electricity cost saved (appr. USD/year)	CO2 emission reduced (appr. ton/year)
6 kW	6,971	6,971
12 kW	13,943	13,943
36 kW	41,828	41,828
96 kW	111,541	111,541

R&D lab : 8Hr/day x 5 work days x 52 weeks

Power	Electricity cost saved (appr. USD/year)	CO2 emission reduced (appr. ton/year)
6 kW	1,747	12
12 kW	3,494	24
36 kW	10,483	71
96 kW	27,955	189

* The data is based on :

1. approximate electricity price 0.14USD/kWh for industry facility in California
2. 1kWh power consumption \approx 0.997 CO emission

* The extra cost of air conditioning is not included.

Application - Burn-in test of power supply for 5G communication

- Server power supply(12V/1000W~2000W)
- 48V power supply(48V/4000~5000W)
- HVDC power supply (240V/280V/336V)
- UPS

New solution Regenerative electronic load



2nd generation solution Energy-consuming electronic load



Programmable
but high electric cost

1st generation solution Resistive load box



Low precision, not programmable,
heavy heat

power supply for
5G communication



IT-M3800 advantage
The increasing channels for burn-in test requires higher power density solutions. IT-M3800 stand-alone 1U unit is well applied to the burn-in test of communication power supplies at different voltage levels under 6kW. Compared with the common 3U units with similar functions in the market, the efficiency of IT-M3800 has increased by nearly 40%.

Electricity accumulation, high energy saving effect

IT-M3800 uses power electronic conversion technology to recycle the output energy of the power supply under test under the premise of completing the test power experiment. Through the internal high-speed voltage and current sampling, the user can directly view the current total amount of feedback on the instrument panel, including voltage/frequency/power of each phase. The total power, real time and historical total recovered electricity. The IT-M3800 series can continue to accumulate electricity on the basis of the value before the last shutdown.

Battery discharge test

The IT-M3800 series have discharge test function, which is suitable for discharging tests on various portable batteries. Three test cut-off conditions of the battery can be set by yourself: cut-off voltage, cut-off capacity and discharge time. When any one of the three conditions is met, the test will be automatically interrupted. During the test, the battery voltage, discharge time and discharged capacity can be observed.

Parallel function

To be convenient and flexible, IT-M3800 uses the master/slave control mode to connect multiple e-loads in parallel to realize high-power testing requirements. Meanwhile, it adopts ITECH's optical fiber parallel technology to solve the problems of slow speed and poor accuracy in the traditional parallel mode, suitable for calibration measurement, research and development lab, production line and ATE test setup.

Digital parallel technology isolated optical fiber, effectively protects equipment/ DUT

stand-alone unit/parallel connection, the same performance/parameters

optical fiber technology ensures strong anti-interference ability for parallel connection

No need calibration after parallel connection

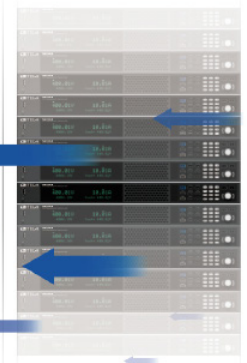

* Parallel connection for over 16 units, please contact ITECH.



Multi operation modes

IT-M3800 provides four basic operating modes of CC/CV/CR/CW.

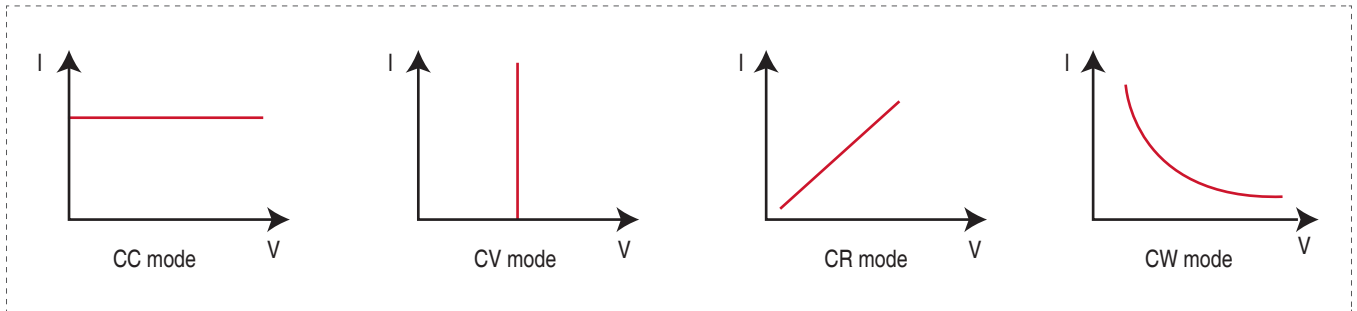

IT-M3800 supports 4 operation modes below :

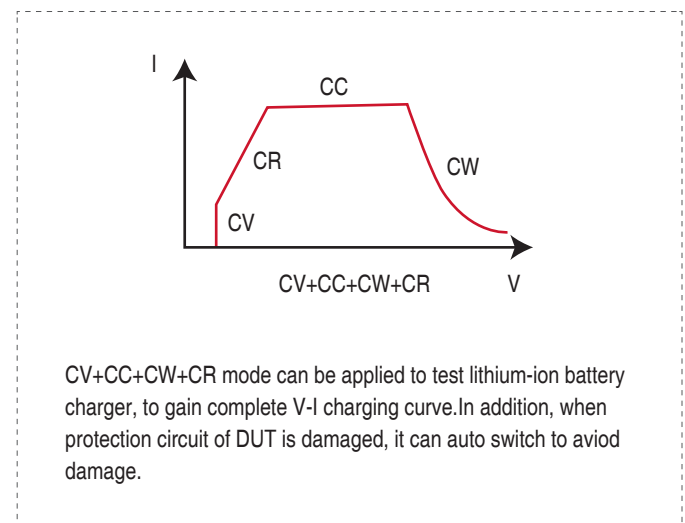
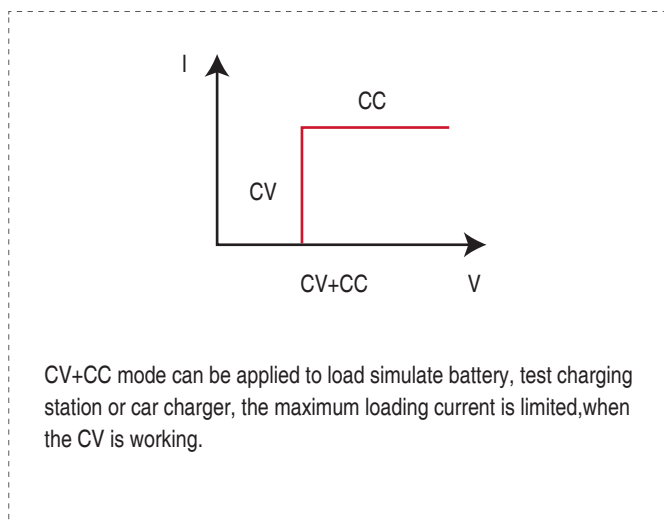
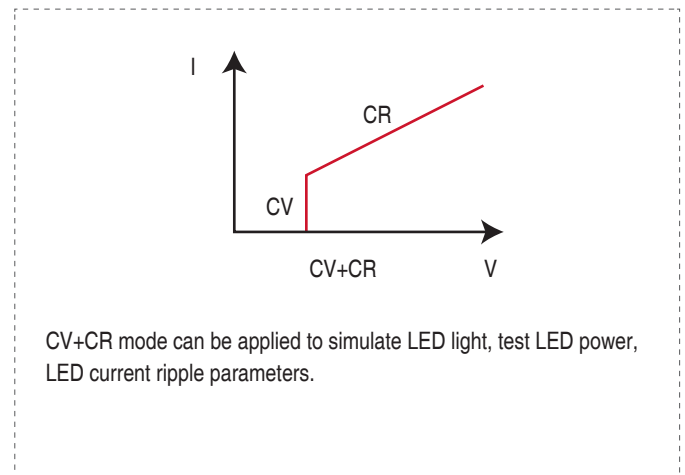
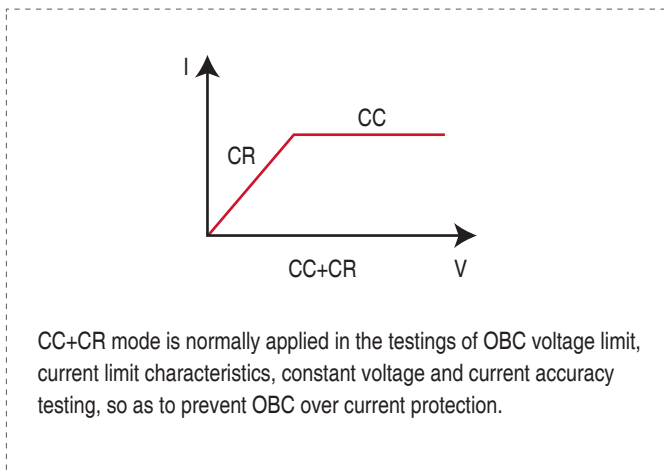

Rear panel interface

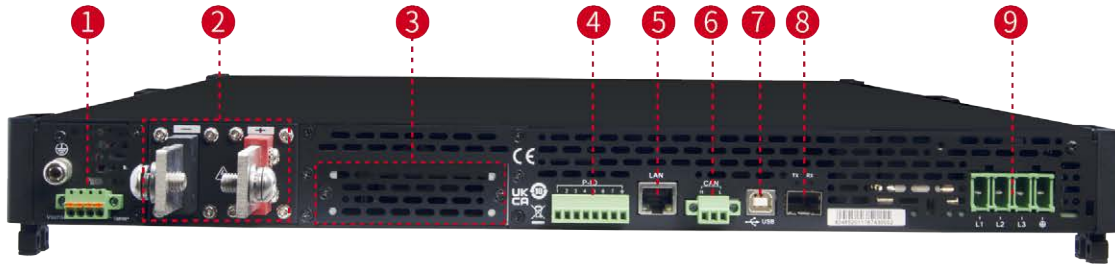

1 Rear panel interface



2 DC input terminals



3 Optional expansion slot



4 Digital I/O interface P-IO



5 LAN interface



6 CAN interface



7 USB interface



8 External optical fiber interface (TX and RX)



9 AC input terminals (L1, L2, L3, PE)



Optional accessories

Category	Model	Specifications	Description
Parallel kit	IT-E4029-15U	IT15U cabinet	800mm×550mm X907.6mm
	IT-E4029-27U	IT27U cabinet	800mm×600mm×1362.75mm
	IT-E4029-37U	IT37U cabinet	800mm×600mm×1764.35mm
	IT-E168	Parallel optical fiber	For parallel use
	IT-E155A/B/C	Rack-mounting kit	Rack mounting installation
Function module	IT-E165A-250 *1	Anti-reverse module 750V/250A	Anti-reverse protection
	IT-E165A-400 *1	Anti-reverse module 750V/400A	Anti-reverse protection
	IT-E165A-500 *1	Anti-reverse module 900V/400A	Anti-reverse protection
Other accessories	IT-E258	3U module power cord, 5m, China standards	AC input power cord
	IT-E258-15U	15U cabinet power cord, 5m, China standards	AC input power cord
	IT-E258-27U	27U cabinet power cord, 5m, China standard	AC input power cord
	IT-E258-37U	37U cabinet power cord, 5m, China standard	AC input power cord
	IT-E176	GPIB communication card	
	IT-E177	RS232&Analog communication card	

*1 The DUT's voltage and current should be within the rated range of IT-E165A.





IT-M3300 Regenerative DC Electronic Load

High efficient power regeneration

Battery discharge test

8 operation modes

Independent control of multiple channels



IT-M3300 regenerative DC electronic load can not only simulate various load characteristics, but also can feed back electrical energy to the local grid instead of heat. With high power density design, it can provide up to 800W power absorption with tiny body of only 1U half-rack. Its flexible modular architecture design can meet the test requirement of customers with different current and power. At the same time, it has high-precision setting and measurement, and has made a number of safety designs for the test. It is suitable for test applications such as various types of battery discharge, multi-channel power supply, and semiconductor aging.

Feature

- 1U half rack, high power density
 - Battery discharge test
 - High efficient power regeneration
 - 8 operating modes: CC/CV/CP/CR/CV+CC/CC+CR/CV+CR/CV+CC+CP+CR
 - Independent control of multi-channels, implement synchronization or proportional tracking
 - Parallel connection, up to 16 units
 - High-speed measurement, keep 10 times / s update rate even connecting 16 stand-alone units
 - Adjustable current rise/fall time
 - List programming
 - Various protection such as OCP/UCP/OVP/UVF/OPP, over heat protection, grid fault protection and fault storage, foldback, Power-off protection, sense abnormal protection
 - Temperature measurement function, over temperature protection
 - Automatic detection of power grid state to realize reliable grid connection
 - Precharge function to prevent overshoot of DC loading current
 - Anti-reverse protection function by optional IT-E118
- Five optional interfaces, supporting RS232, CAN, LAN, GPIB, USB_TMC, USB_VCP, RS485, analog and IO communication

Model	Voltage	Current	Power	Model	Voltage	Current	Power
IT-M3312	60V	30A	200W	IT-M3314	300V	6A	200W
IT-M3322	60V	30A	400W	IT-M3324	300V	6A	400W
IT-M3332	60V	30A	800W	IT-M3334	300V	6A	800W
IT-M3313	150V	12A	200W	IT-M3315	600V	3A	200W
IT-M3323	150V	12A	400W	IT-M3325	600V	3A	400W
IT-M3333	150V	12A	800W	IT-M3335	600V	3A	800W

Applications

Burn-in testing solution for multi-channel power supply module

Burning test of LED driver, DC-DC or AC-DC modules' burn-in test.

Working condition simulation, verification of electrical performance of products.

Electrical performance test of mobile phone main board, adapter performance test, small DC generator test

Semi-conductor power IC, relay, and wire harness, etc.

Power regulator, smart electronic switch IPS, and burn-in test of automotive central control box

Discharging test of various types of batteries

Battery capacity test, screening of disqualified batteries

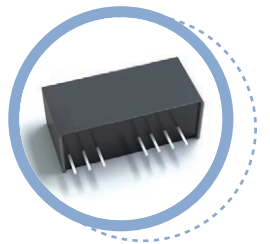

1U half rack, mini size

IT-M3300 has mini size of 1U half rack and is able to input 800W. It has not only the high density but also the high resolution, accuracy, stability and etc. The input voltage can reach 600V and the input current can reach 30A. There're 12 models for IT-M3300 series, with design of wide range input, with one unit, it can cover a wide range of application requirements.



Module design, flexible combination

IT-M3300, with module design, without additional spare parts, it can be stacked as easy as the toy bricks. With IT-E154 rack installation kit, users can easily install one or multiple instruments into a standard 19-inch cabinet.

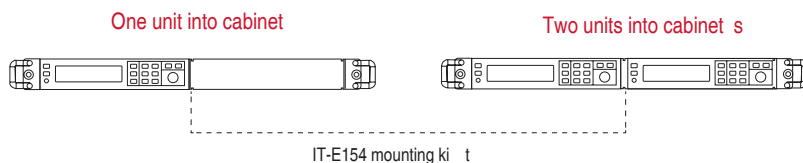

High energy recovery efficiency

IT-M3300 has energy recovery function, which can feedback power back to local AC grid. The regeneration efficiency can be up to 90%, which greatly reduces the user's electricity cost. It also avoids the using of cooling systems and reduces noise.

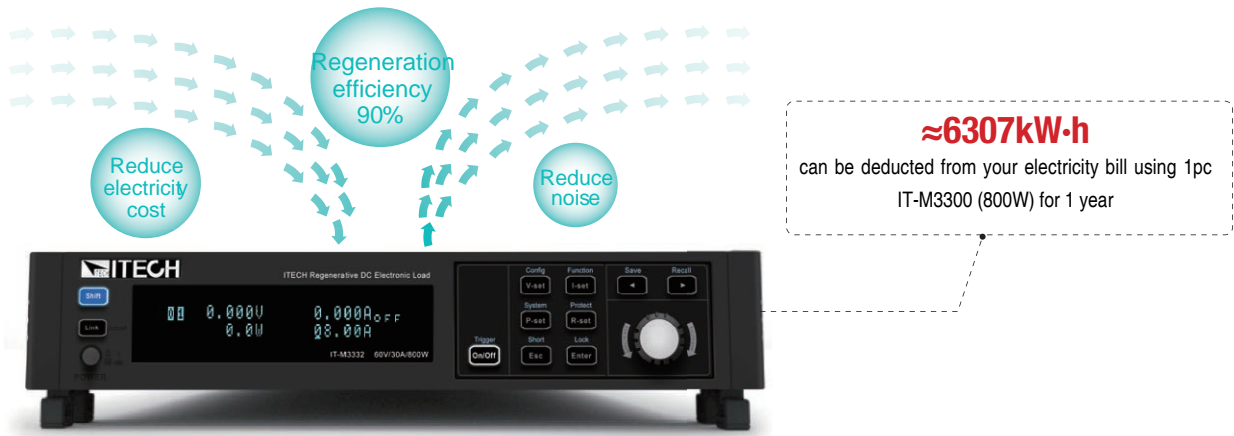

Electricity accumulation, high energy saving effect

IT-M3300 uses power electronic conversion technology to recycle the output energy of the power supply under test under the premise of completing the test power experiment. Through the internal high-speed voltage and current sampling, the user can directly view the current total amount of feedback on the instrument panel.

The IT-M3300 is equipped with temperature measurement function as standard. With an optional temperature sensor, you can also directly view the external measurement temperature.

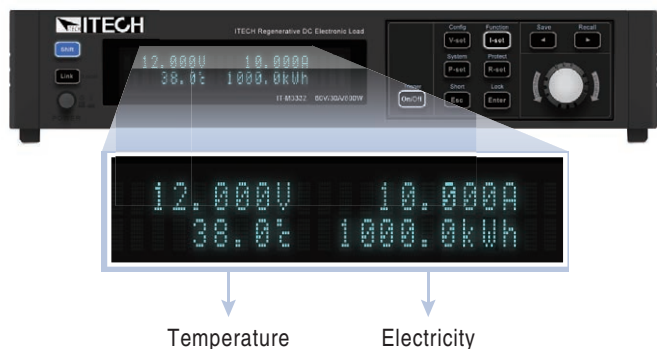

Parallel function

IT-M3300 supports multiple units of same model in parallel to create a system with greater current and power. The user takes the master-slave operation according to the current value of different requirements; maximum up to 16 instruments can be connected in parallel.

The IT-M3300 still have high-speed measurement capability after parallel connection and this speed is almost as same as the single unit.

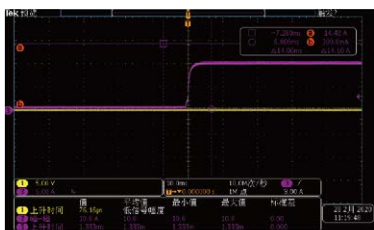

Single unit

VS

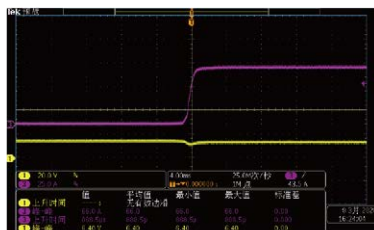

Two units in parallel

Multi-channel independent control, maximum 256 channels

IT-M3300 series is provided with independent multi-channel design. The channel sequence will be displayed when it combines to be a multi-channel electronic load system. The user can control each unit independently by GUI software when connecting the communication interface of one unit with PC. Each channel can be operated separately.

IT-M3300 series supports maximum 16*16 channels. One 37U rack contains 64 channels. The user may test DUT with different power ranges by parallel connection, making tests more flexible and device usage more efficient.

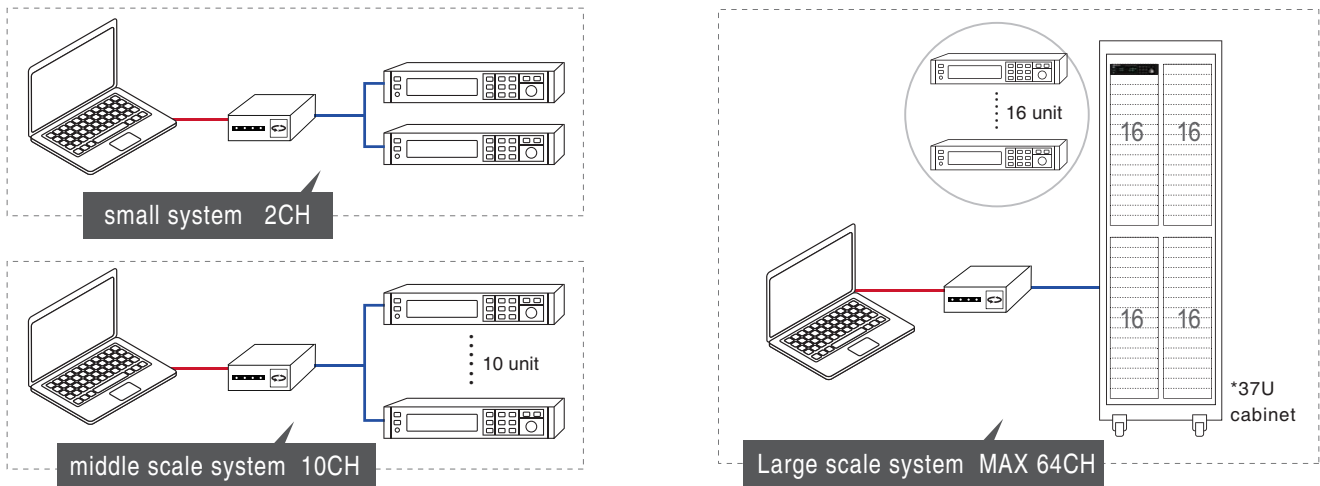

Battery simulation

Battery charger will monitor the voltage of battery after battery charger is connected to battery, if the connection is correctly, the battery charger comes into charge state. In Battery Sim mode, users can set analog voltage of battery, and can output low current, to simulate battery state. It can satisfy working demand of battery charger, which can be applied to discharging test of battery charger.





Multiple operation mode

IT-M3300 provides CC/CV/CP/CR four basic operation mode.

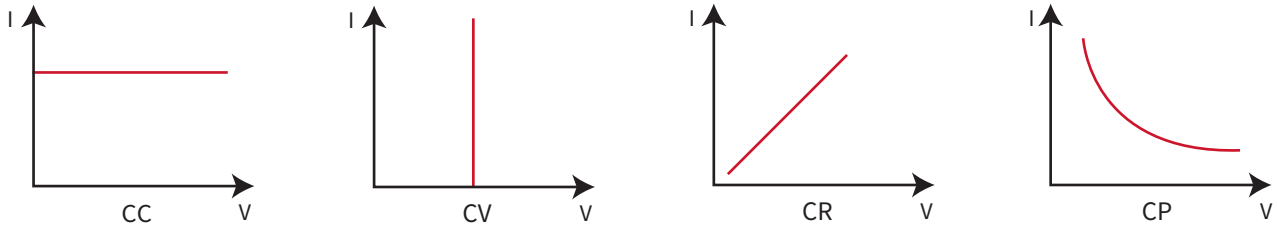

IT-M3300 also provides CC+CR/CV+CR/CV+CC/CC+CV+CP+CR four combined operation mode, which can be applied to the test requirements of various occasions.

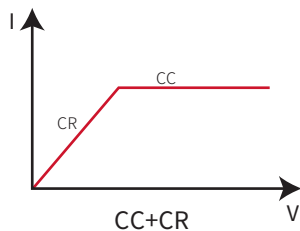

CC+CR mode can be applied to OBC feature test of voltage limit, feature test of current limit, constant voltage accuracy test, constant current accuracy test, to prevent over current protection.

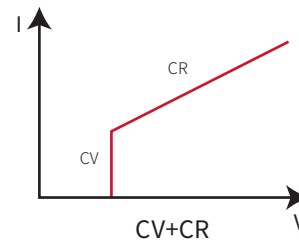

CV+CR mode can be applied to simulate LED light, test LED power, LED current ripple parameters.

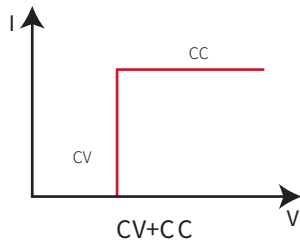

CV+CC mode can be applied to load simulate battery, test charging station or car charger, the maximum loading current is limited, when the CV is working.

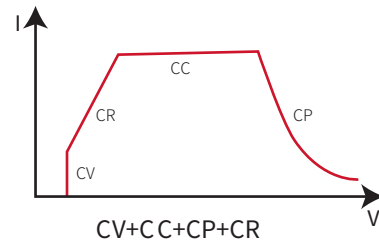

CV+CC+CP+CR mode can be applied to test lithium-ion battery charger, to gain complete V-I charging curve. In addition, when protection circuit of DUT is damaged, it can auto switch to avoid damage.

List function

IT-M3300 does not need any software, according to users test demand, it can edit waveform generated by voltage and current, and can control voltage rising slope and falling slope. When receiving the trigger signal, it can switch loading waveform automatically.

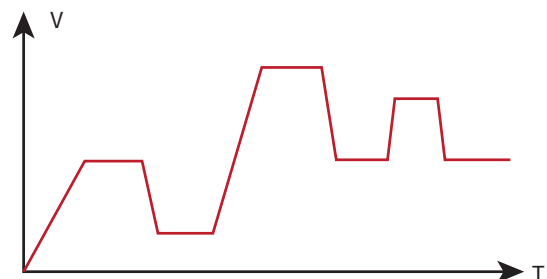

Battery discharge test

The battery discharge function of IT-M3300 allows you to proceed the discharge test of battery under CC mode. 3 cut off conditions can be set, including voltage, capacity and discharge time. When any of the three conditions are met, it will automatically stop the test. The battery voltage, discharge time and discharged capacity can be monitored during the test.

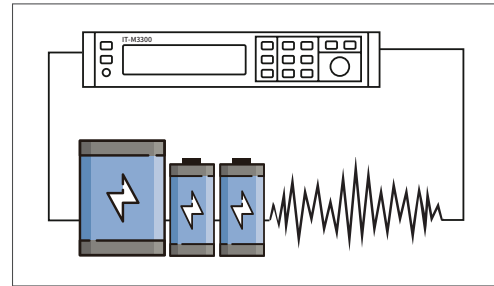

Full protection

IT-M3300 has OCP / UCP / OVP / UVP / OPP / over heat protection, power grid fault protection and fault storage function, power off protection function and Sense function. The power grid state automatic detection function helps to shut down the instrument when the power is suddenly cut off, so as to realize reliable grid connection function and island protection function. The precharge function prevents current overshoot. Equipped with the optional anti-reverse connection module, the anti-reverse connection protection function can be realized to effectively suppress the inrush current.

Optional accessories

IT-M3300 series provides below optional multiple interfaces on rear panel to realize different functions, like communication interface, external analog interface.

Pictures	Model	Interface
	IT-E1205	GPiB
	IT-E1206	USB/LAN
	IT-E1207	RS-232/CAN
	IT-E1208	Analog/RS485
	IT-E1209	USB
	IT-E118	Anti-reverse module
	IT-E1203	Temperature Sensor
	IT-E154A/B/C	Rack mount kit

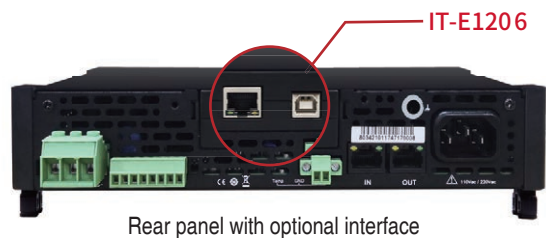



IT8000 Regenerative DC Electronic Load



Applications

Multiple types of batteries Charge-Discharge Testing, Natural energy virtual load test, safety testing of mechanical systems with large capacity batteries, Aging test (automotive high voltage motor, fuse, relay) and small motors testing.

Feature

- Recover DC energy to local grid with efficiency up to 95%
- Stand-alone power up to 144kW, expandable by master-slave paralleling up to 2MW
- Stand-alone input voltage up to 2250V
- Stand-alone input current up to 2040A
- High power density design provides 18kW in 3U space
- LIST function, support importing LIST files by USB
- Power accumulation function
- Battery test function, short circuit test function
- Full protection: OVP/OCP/OPP/OTP/UVP, Vsense anti-reverse connection protection, and voltage transient drop protection
- Built-in standard USB/CAN/LAN/digital IO interface, and optional GPIB/Analog&RS232 interfaces
- Support SCPI protocol, LabVIEW
- Operating mode: CC/CV/CP/CR/CC+CV/CV+CR/CR+CC/CC+CV+CP+CR

*The regenerated power is for local grid purpose, not for public grid purpose.

IT8000 series is a family of high power regenerative electronic loads with compact size. The highly integrated capability enables the e-load to simulate various e-load characteristics, and return the consumed energy back to the grid cleanly, saving costs related to energy consumption and cooling, meanwhile eco-friendly. With modular high power density design, IT8000 provide up to 18kW in 3U space. The power is expandable up to 2MW by master-slave paralleling and active current sharing. If you move into application of high power UPS, storage battery, PV battery, EV, energy storage system, ITECH can help you with IT8000 series high power regenerative electronic load.

Power Accumulation Function

IT8000 series regenerative DC electronic load uses the power electronic transformation technology on the premise of completing test power experiment to make output energy of measured power supply regenerative recycled and reused. Through the inside fast sampling of voltage and current, the regenerative power value can be observed on the front panel of IT8000 series, including voltage, frequency and power of each phase, as well as total power, total current regenerative and total historical regenerative power, which makes the energy saving effect much easier. Re-open after power failure, IT8000 series will continue to accumulate the regenerative power value based on the last power off value.



	Model	Current	Power	Model	Current	Power	Model	Current	Power		
80V	IT8005-80-150	150A	5kW	300V	IT8006-300-75	75A	6kW	500V	IT8006-500-40	40A	6kW
	IT8010-80-300	300A	10kW		IT8012-300-150	150A	12kW		IT8012-500-80	80A	12kW
	IT8015-80-450	450A	15kW		IT8018-300-225	225A	18kW		IT8018-500-120	120A	18kW
	IT8030-80-900	900A	30kW		IT8036-300-450	450A	36kW		IT8036-500-240	240A	36kW
	IT8045-80-1350	1350A	45kW		IT8054-300-675	675A	54kW		IT8054-500-360	360A	54kW
	IT8060-80-1800	1800A	60kW		IT8072-300-900	900A	72kW		IT8072-500-480	480A	72kW
	IT8075-80-2040	2040A	75kW		IT8090-300-1125	1125A	90kW		IT8090-500-600	600A	90kW
	IT8090-80-2040	2040A	90kW		IT8108-300-1350	1350A	108kW		IT8108-500-720	720A	108kW
	IT8105-80-2040	2040A	105kW		IT8126-300-1575	1575A	126kW		IT8126-500-840	840A	126kW
	IT8120-80-2040	2040A	120kW		IT8144-300-1800	1800A	144kW		IT8144-500-960	960A	144kW

	Model	Current	Power	Model	Current	Power	Model	Current	Power		
800V	IT8006-800-25	25A	6kW	1500V	IT8018-1500-40	40A	18kW	2500V	IT8018-2250-25	25A	18kW
	IT8012-800-50	50A	12kW		IT8036-1500-80	80A	36kW		IT8036-2250-50	50A	36kW
	IT8018-800-75	75A	18kW		IT8054-1500-120	120A	54kW		IT8054-2250-75	75A	54kW
	IT8036-800-150	150A	36kW		IT8072-1500-160	160A	72kW		IT8072-2250-100	100A	72kW
	IT8054-800-225	225A	54kW		IT8090-1500-200	200A	90kW		IT8090-2250-125	125A	90kW
	IT8072-800-300	300A	72kW		IT8108-1500-240	240A	108kW		IT8108-2250-150	150A	108kW
	IT8090-800-375	375A	90kW		IT8126-1500-280	280A	126kW		IT8126-2250-175	175A	126kW
	IT8108-800-450	450A	108kW		IT8144-1500-320	320A	144kW		IT8144-2250-200	200A	144kW
	IT8126-800-525	525A	126kW								
	IT8144-800-600	600A	144kW								

* This information is subject to change without notice

List Function

IT8000 series regenerative DC electronic load provides list mode, it can complete the complex arbitrary current change mode accurately and fast, and can synchronize with internal or external signals to complete multi-level loading precision test, which greatly save cost for customers. By editing the step value, pulse width and the slope of each step, IT8000 can generate a variety of complex sequences and help users to complete various loading waveforms test. In the CC mode, IT8000 series can set rising and falling speed.

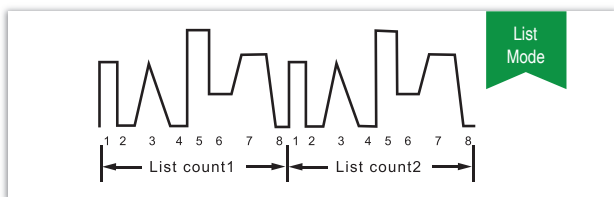

Battery Test Function

IT8000 series regenerative DC electronic load simulate battery discharge test under CC mode, and support settable discharge cut-off conditions, such as cut-off voltage, cut-off capacity and cut-off time. When any of the three conditions are met, the discharge test will be stopped. Moreover, the battery voltage, discharge time and the discharged capacity can be observed during the test, which reflects the reliability of the battery and its remaining life.

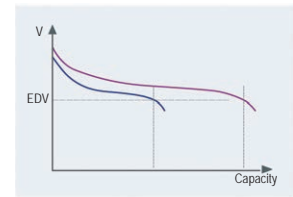
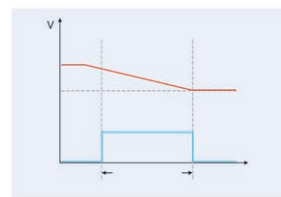



Parallel technology

- IT8000 has adopted ITECH parallel technology
- All the function and performance will be the same as standalone unit
- No need to calibrate after paralleling
- Fiber transmission, good for anti-interference
- Digital paralleling, fully insulated, good for protecting DUT

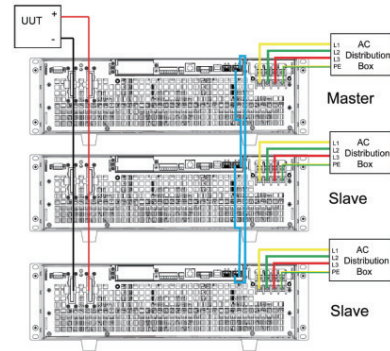

Full protection

IT8000 series regenerative DC electronic load supports automatic detection the grid state . When grid connection is suddenly disconnected or power down, IT8000 will be turned off. IT8000 series can achieve reliable on-grid function and anti-islanding protection function. IT8000 supports monitoring on DC input voltage and frequency, and supports OCP, OVP, OTP, OPP function.



Power regenerative efficiency up to 95%

High energy regenerative efficiency. The IT8000 series has a unique energy regenerative function that can regenerate electrical energy and then directly use it in the plant instead of consuming it in the form of heat. Its conversion efficiency can up to 95%, which not only will greatly reduce the user's electricity cost, but also avoid the use of air conditioning or expensive cooling systems.

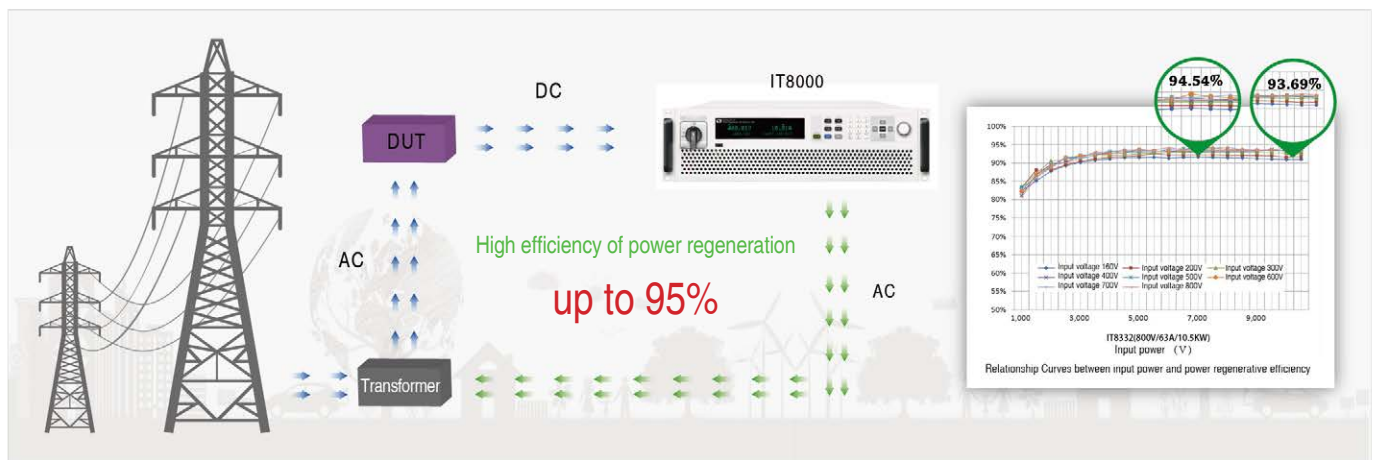

High power density

Conventional electronic loads are not only with high energy consumption, but also with very large size and weight. Energy consumption electronic load with 30kW load is at least 24U, it is difficult to transport and the cost is higher. IT8000 series regenerative DC electronic load adopts high power density design of 18kW in only 3U high. Compared to conventional electronic loads, the size for IT8000 series is decreased by 80% under the same output power.

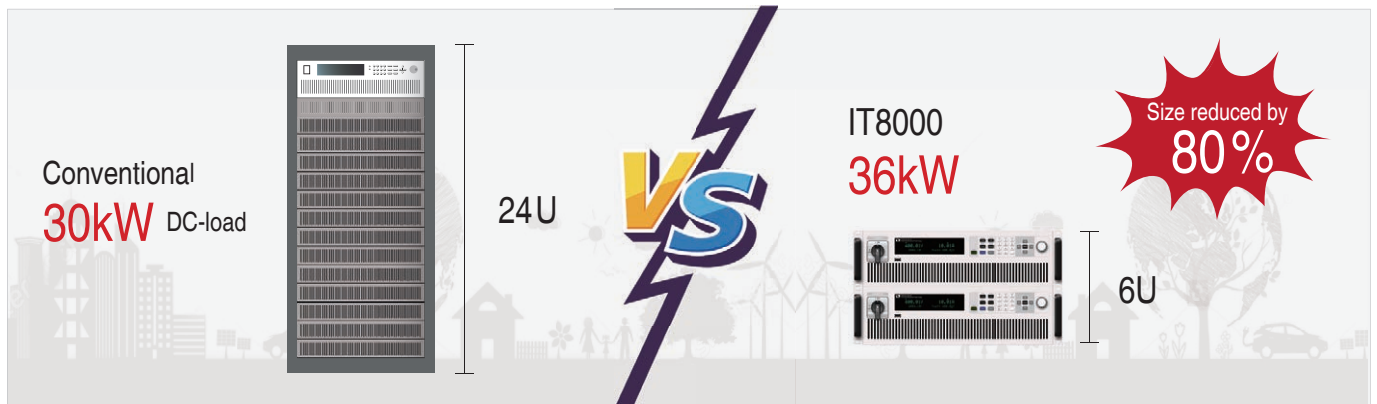

Multiple interfaces

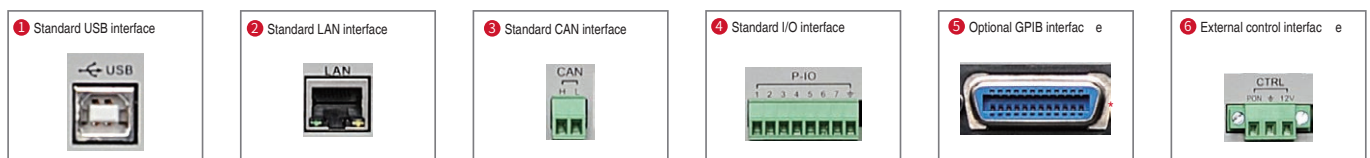
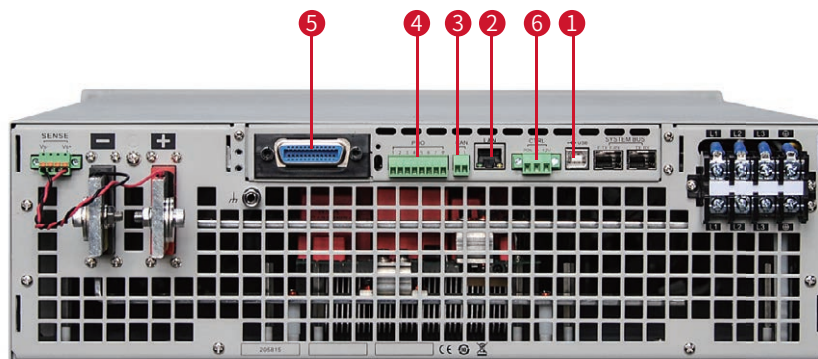

* Optional GPIB or Optional RS232 & Analog

IT8700P+ High Speed Multi-channel DC Electronic Load

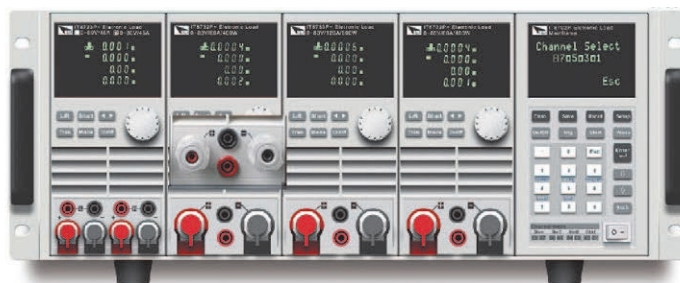

IT8700P+ series high-speed multi-channel DC electronic load is an upgraded version of the original IT8700P series with higher speed and higher precision. Its modules support master-slave paralleling connection for power extension. It's compatible with IT8700P mainframe, the new modules and old modules can work together. The IT8700P+ modules have faster dynamic response and can make the minimum rise time of current less than rising time of minimum current < 10 μs. In addition, the low internal resistance makes it suitable for low-voltage loading test. Faster loop speed can accurately control current without overshoot which improves test efficiency. Furthermore, it has three current ranges for higher accuracy and lower ripple. The voltage and current measurement speed of this series has been upgraded to 250kHz. It has built-in LAN, USB and RS232 interfaces, and supports SCPI protocol. Therefore, IT8700P+ is good for system integration and is suitable for R&D and production line testing of super capacitors, fuel cells, lithium ion batteries, high-speed AC-DC and DC-DC power supplies such as computer power supplies and communication power supplies.

Feature

- Three-stage current range, higher accuracy and lower ripple
- Supports master-slave parallel connection of 16-channel modules, flexibly extends power
- Faster dynamic response, minimum current rise time < 10 μs
- Stable operation down to zero volts, suitable for low-voltage capacitors, solar cells, fuel cells, and other low-voltage high current power supplies.
- Faster loop speed, precise control of current without overshoot
- The voltage and current measurement speed is upgraded to 250kHz, good for system integration
- Comprehensive protection functions: OVP/OCP/OPP/OTP, Sense protection
- Compatible with IT8700P mainframe, old and new modules can be matched
- Short-circuit peak current measurement function
- Available front/rear terminals*1
- 8 operating modes: CC/ C-V/ CR/ C-W/ C-V+CC/ CR+CC/ CW+CC/ C-V+CR (CR-LED)
- Automatic test function to tell whether the test results exceed the set specifications
- Built-in LAN, USB, RS232 interfaces
- CV loop speed is adjustable to match different DUT
- Multi channel synchronous control

*1 Current is no more than 15A if connecting with mainframe

Model	Voltage	Current	Power
IT8721P+*1	150V	20A	2*100W
IT8731P+*1	150V	40A	200
IT8732P+*1	150V	60A	400W
IT8722P+*1*2	150V	20A	2*250W
IT8723P+*1	150V	45A	2*300W
IT8733P+*1	150V	120A	600W
IT8732BP+	600V	20A	300W
IT8733BP+	600V	30A	500W
IT8722BP+*2	600V	15A	2*250W

Main Frame	
IT8701P	Mainframe for 2 modules (including three interfaces)
IT8702P	Mainframe for 4 modules (including three interfaces)
IT8703P	Expansion mainframe for 4 modules

*1 Coming soon

*2 Dynamic power allocation, the total power of two channels is 300W, and the power of one channel does not exceed 250W

Applications



Flexible modules combination

The IT8700P+ series is designed with removable modules, so that you can choose different modules according to your needs. These modules can work with the original IT8700P series modules too. There are high-performance microprocessor chips in each load module and mainframe. Parallel architecture is adopted to achieve faster testing. The load modules are controlled synchronously by the system, and the power supply with multiple outputs can also be tested synchronously.

Fast dynamic response

Power supplies often have high requirements for instantaneous signals and dynamic response. In order to meet faster and faster testing requirements, IT8700P+ series provides high-speed, programmable dynamic sequence control. The current rise time is no more than 10 μs , much faster than the last generation. So it can be used for high-speed dynamic test of communication power supply and computer power supply. There are three modes of the dynamic test function, namely continuous mode, pulse mode and toggle mode.

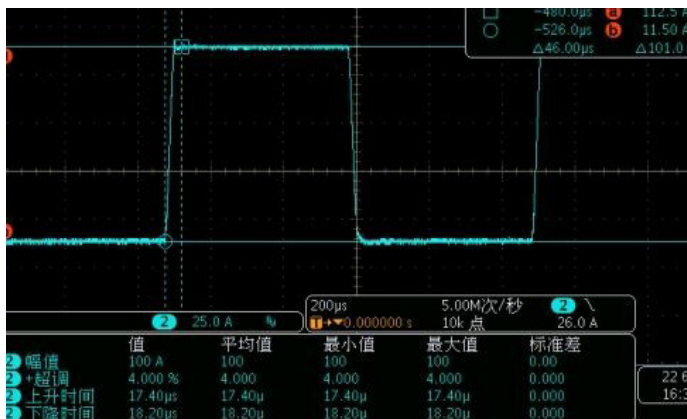

IT8733P+ (80V,120A,600W) 10A~110A dynamic waveform (current slope 5A/ μs)

Master-slave parallel connection

The IT8700P+ series supports master-slave parallel connection, 8 units (16 channels) at most can be connected in parallel, and the power can be extended to 4800W. The synchronization time error is 4 μs between paralleled units, and current equally assigning accuracy is 0.1%+0.1%F.S. Thanks to the flexible power extension, it can be used to test various DUTs and increase equipment utilization. The current sharing mode makes no sacrifice of the dynamic performance after parallel connection.

3 current ranges, well applied to Energy Star standard test for consumer electronics products

IT8700P+ provides 3 current ranges and higher measurement accuracy for DUTs that require high current accuracy like batteries. No need to build a complex test bench, the low current range of the IT8700P+ can be used for Energy Star standard testing in sleep, idle and standby modes of consumer electronics products. Actually it is suitable for almost all consumer electronics products that require precise current setting and measurement at the μA and mA levels.



Low voltage loading, stable operation down to zero volts

The IT8700P+ module has ultra-low on-resistance and three ranges. Under the medium and small range, the minimum load voltage is <math><0.1V</math>. In the high current range, the minimum load voltage at full current is <math><0.5V</math>, and lower input impedance can be obtained after parallel connection. It is suitable for testing fuel cells, supercapacitors, solar cells, DC-DC converters and other low voltage and high current electronic devices.

Fast measurement of I-V characteristic

The voltage and current measurement of IT8700P+ is fast (up to 250kHz). It can be applied to various testing applications such as charging piles, automotive electronics; renewable energy and so on.

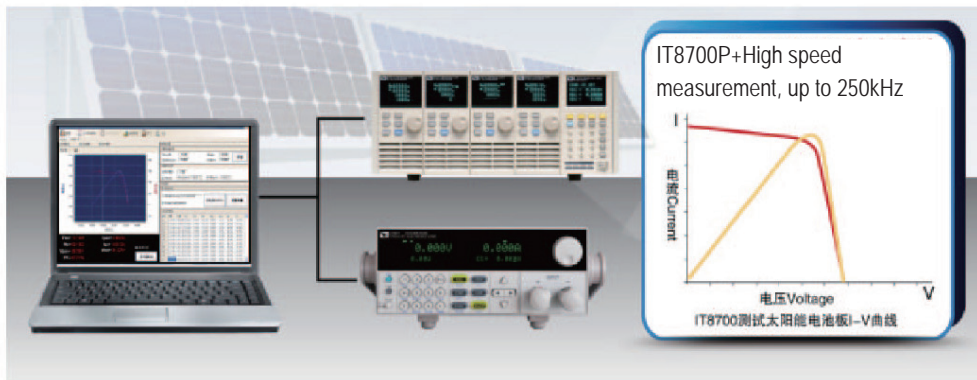

Peak voltage measurement(Vpk)

When measuring the dynamic current of a switching power supply, an oscilloscope was usually necessary to capture the instantaneous voltage and current waveforms and obtain V_{pk+} and V_{pk-} accordingly. But with digital data acquisition function, IT8700P can directly obtain the V_{pk+} and V_{pk-} values without an oscilloscope.

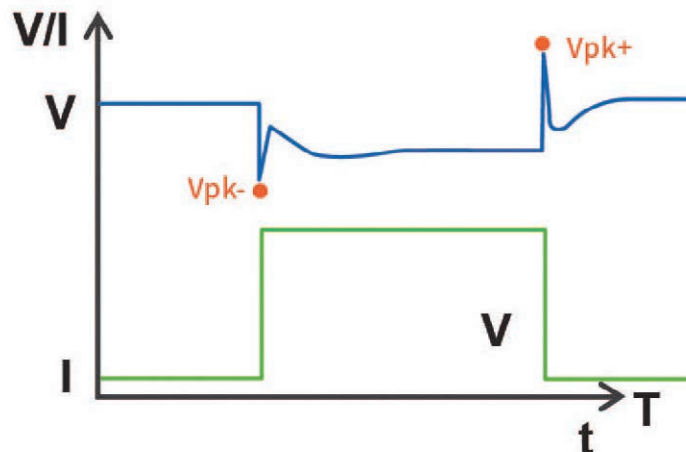

8 operation modes

Besides the four basic operation modes of CC/CV/CR/CW, IT8700P+ provides additional 4 new compound operation modes included in IT8700P+ series : CV+CC/CR+CC/CW+CC/CV+CR(CR-LED). Under CV/CR/CW operation mode, the maximum current (I-Limit) is settable. This can effectively solve the problem of instantaneous surge current during testing and avoid triggering DUT's protection, or even burning out or any other injury caused by possible misoperation or environmental factors.. So it can be used in various applications.

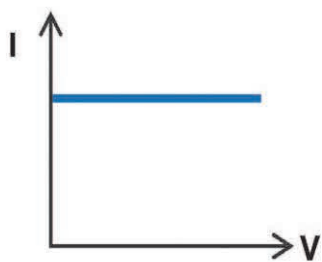

CC 模式

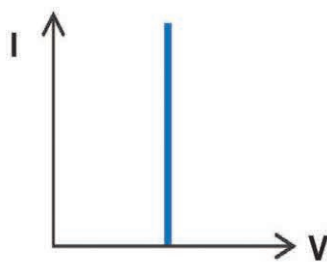

CV 模式

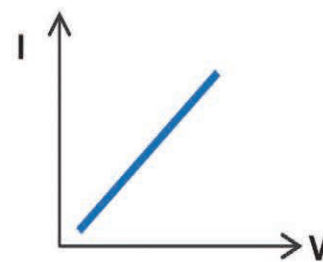

CR 模式

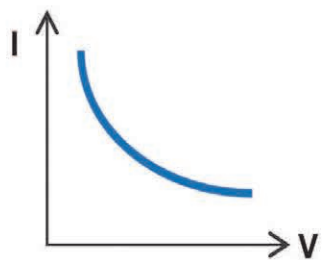

CW 模式

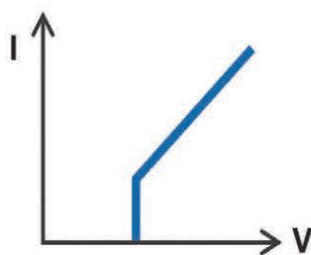

LED(CV+CR) 模式

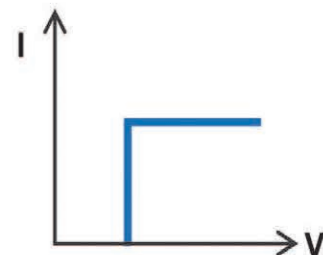

CV+CC 模式

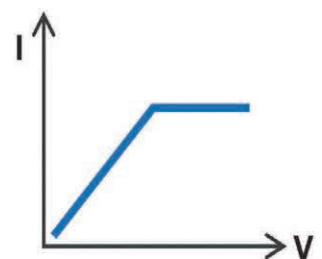

CR+CC 模式

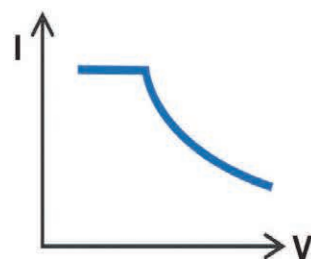

CW+CC 模式

IT8700P Multi-channel Modular Programmable DC Electronic Load

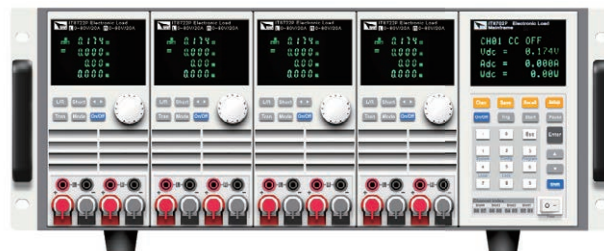

IT8700P series multi-channel modular programmable DC electronic load has been upgraded on the basis of IT8700, follow the original modular design. A single frame can reach 8 channels, and extended frame can reach 16 channels. It is equipped with both front and rear terminals, which can meet various testing requirements of users.

Same as IT8700, IT8700P also has the functions of slope adjustment and waveform editing. Besides, IT8700P has increased the functions including maximum current limit, PLC setting and CV loop adjustment. Users can set the automatic test function in the upgraded 8 operating modes, which is convenient for fast and accurate testing on R&D and production lines. At the same time, IT8700P series has full protection such as OVP, OCP, OPP, OTP, etc., which can prevent damage or injury caused by miss operation or environmental factors.

Feature

- Removable modules for easy system configurability
- Dual-channel module can display each channel data simultaneously
- Single frame up to max.8 channels, extended frame up to max.16 channels
- Dynamic power distribution function for dual channels
- Arbitrary selection of front/rear terminal
- Users can customize the left and right modules
- 8 operation modes: CC/CV/CR/CW/CV+CC/CR+CC/CW+CC/CV+CR(CR-LED)
- CV loop speed is adjustable to match different power supplies
- High resolution and accuracy up to 0.1mV/0.01mA
- Measurement of short-circuit peak current and peak voltage
- Voltage and current measurement, up to 50kHz
- Adjustable current rise/fall slope
- Simulate various waveforms with load under List mode
- Up to 25kHz dynamic mode, 100kHz List mode setting
- Automatic test function can automatically determine whether the test results exceed the set specifications
- Simultaneously perform multiple sets of electronic load modules
- OVP/OCP/OPP/OTP/anti-reverse protection
- Standar Lan/USB/RS232 communication interface

*For any GPIB interface option request , check with ITECH for availability.

Modules	Specification
IT8731P	80V/40A/200W
IT8732P	80V/60A/400W
IT8732BP	500V/20A/300W
IT8733P	80V/120A/600W
IT8733BP	500V/30A/500W
IT8722P	80V/20A/250W*2CH
IT8722BP	500V/15A/250W*2CH
IT8723P	80V/45A/300W*2CH

Main Frame	
IT8701P	Two-load module main control unit (including three interfaces)
IT8702P	Four-load module main control unit (including three interfaces)
IT8703P	Four-load module expansion unit

*1: The total power of dual channel for IT8722P/IT8722BP is 300W, namely $PCH1+PCH2 \leq 300W$

Two channels working range ($0W \leq PCH1/PCH2 \leq 250W$); Upper limit of two channels setting range ($50W \leq PCH1/PCH2 \leq 250W$)

*2: IT8700P modules need to be configured with IT8702P main frame.

*3: Interfaces of main frame: RS232, USB, LAN

Load Terminals On Front Read Panel

IT8700P is equipped with both front binding post terminals and rear terminals. Both of them can be connected for testing. It meets different test requirements and helps to avoid operational errors as well, which lead to higher test efficiency. At the same time, IT8700P is only 4U in height, making it easy to be rack mounted, which is good for system integration.

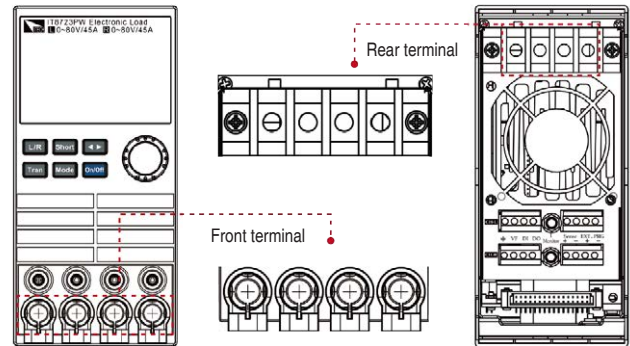

Dynamic testing and control

The operation of dynamic load is periodically switched between the two levels. The adjustment rate and instantaneous response of the power supply monitor its output voltage waveform under the mixed changes of high and low current levels, continuous time and rise/fall rates.

The dynamic test function of IT8700P series can be divided into continuous mode, pulse mode and flip transfer mode.

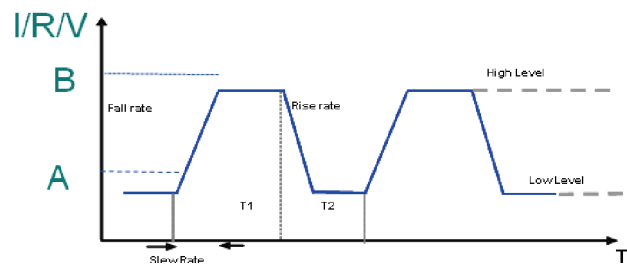

8 operation modes

Besides the four basic operation modes of CC /CV/CR/CW, there are additional 4 new compound operation modes included in IT 8700 P series : CV+CC/CR+CC/CW+CC/CV+CR(CR-LED). Under CV/CR/CW operation mode, the maximum current (I-Limit) is settable. This can effectively solve the problem of instantaneous surge current during testing and avoid the protection triggering, damage of the instrument or any other injury caused by possible miss operation or environmental factors. So it can be used in various applications.

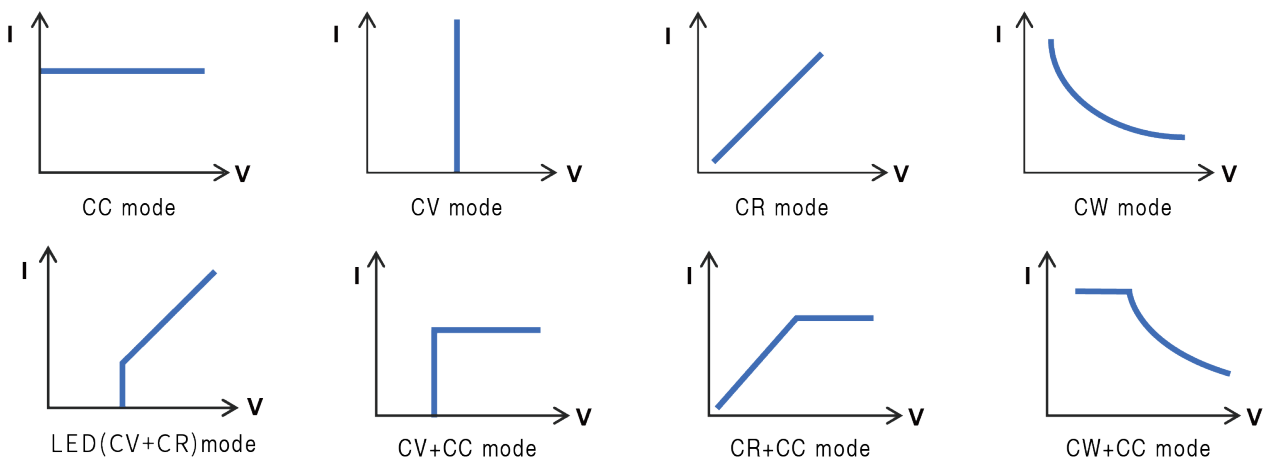

Freely configurable modular system architecture

IT8700P adopts modular design, which has a high-performance microprocessor in every module and mainframe. It has high measurement speed because of parallel architecture. The mainframe controls each models synchronously and show the testing values in real time.



Dynamic power distribution

The model of dual-channel IT8700P has dynamic power distribution function, which helps to save equipment purchasing cost. Different from traditional distribution mode, when the total power is not more than 300W and the single channel power is less than 250W, its power can be freely allocated to the two channels. The user can adjust the two-channel load power of IT8700P to the required power ratio according to the actual test requirements, so that the utilization can be optimized. For example, when you need 130W+170W or 50W+250W dual-channel load, only a single IT8700P module can fulfill the test.

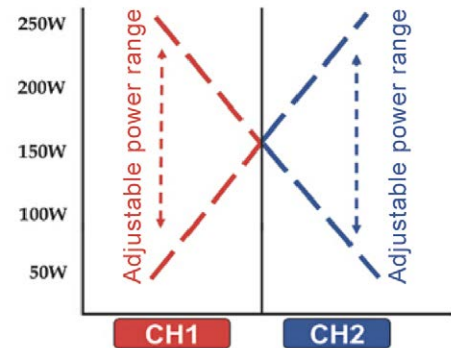

Application

PC ATX 6-channel power supply test

-Only 3 IT8700P modules needed

Recommended solution

-IT8722P module 1: +12V1DC (250W) / -12VDC (50W)

-IT8722P module 2: +12V2 DC (250W) / +5V SB (50W)

-IT8722P module 3: +5VDC (150W) / +3.3VDC (150W)

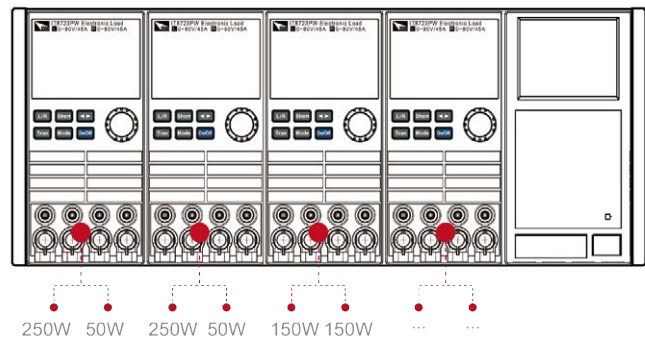

* When the total power is not more than 300W and the single channel power is less than 250W, its power can be freely allocated to the two channels.

Peak voltage measurement (Vpk)

When measuring the dynamic current of a switching power supply, an oscilloscope was usually necessary to capture the instantaneous voltage and current waveforms and obtain Vpk+ and Vpk- accordingly. But with digital data acquisition function, IT8700P can directly obtain the Vpk+ and Vpk- values without an oscilloscope.

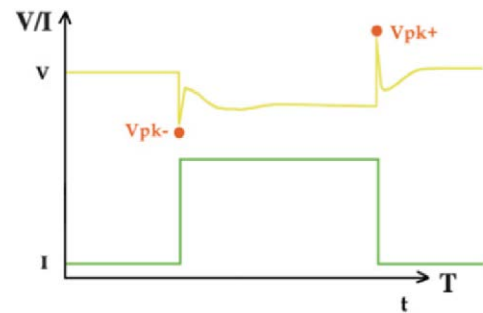

Fast measurement of I-V characteristic curve

The voltage and current measurement of IT8700P is fast (up to 50kHz). It can be applied to various testing applications such as charging piles, automotive electronics; renewable energy and so on.



List function, up to 100kHz

Compared with the dynamic mode, the LIST mode can complete more complex and arbitrary current modes at a high speed instead of the simple double-level changes, so IT8700P can realistically fulfill multi-level load precision tests than other loads. Its built-in waveform generator can simulate multiple waveforms under LIST mode. IT8700P can store 55X7 sets of files to simulate various real loading conditions. In addition, each module can operate independently or synchronously, which means that each module can execute its own timing independently and start working simultaneously.

• Application -Loading test

In the actual test, the product manufacturer tends to load at different current level, such as at 25%, 50%, 75%, 100% of the full-range current, to evaluate whether the value of the voltage fluctuation meets the design purpose. IT8700P can simulate the various complex states of the product in actual working conditions which helps to analyze the performance of the product and then improve it accordingly. IT8700P is especially suitable for complex application environments such as electronic product development, aging of production line, and quality inspection.

Adjustable rise/fall slope

IT8700P has a built-in current slope adjustment loop, users can adjust current rise/fall speed according to different test requirements. Under CC mode, you can set the current rise/fall slope (0.0001-2.5A/7.5A/us)

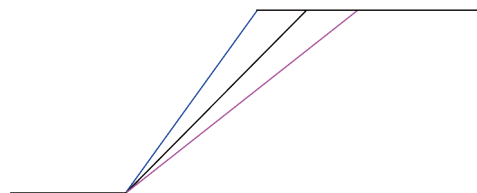

Time measurement

IT8700P has powerful and accurate measurement function, the measurement range is 0.1ms -100,000s. This feature can be applied to battery discharge test, super capacitor discharge electrical time measurement, fuse and circuit breaker trip time measurement, ATX power supply voltage rise time measurement, etc.

• Application -Loading test

IT8700P can display battery test mode, users can set the cut-off condition of battery discharge on the front panel easily. The user can complete the automatic battery charge and discharge test with a simple button operation. For example: when the battery voltage is lower than the first voltage value set by the user, the internal timer of the IT8700P will automatically count, and the timer will not stop counting until the battery voltage drops to the second set voltage.

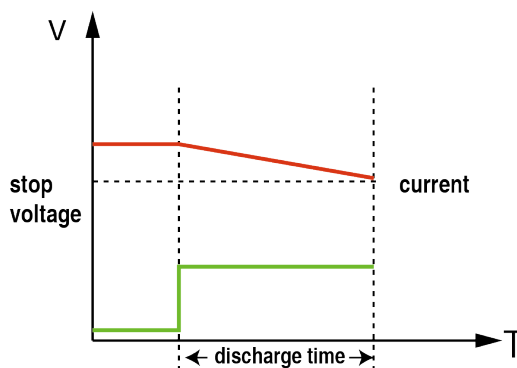

IT8700 Multi-channel Programmable DC Electronic Load



Applications

Multiple or single output AC / DC power supplies, DC / DC power converters, chargers, batteries and other power supply electronic components performance test, ATE test system, solar cells, LED, communications testing, commercial aviation and other fields.

Feature

- Removable modules for easy system configuration
- Dual-channel module can display each channel information simultaneously
- Single frame up to max.8 channels, extended frame up to max.16 channels
- Dynamic power distribution function for dual channels Measurement resolution: 0.1mV/0.01mA
- Measure short-circuit peak current value and peak voltage value
- Measurement speed for voltage, current up to 50kHz
- Adjustable current rising / falling slope
- Auto-test function, with automatic judgement whether the test result exceeds the set specification
- Simulate various waveforms with load under List mode
- Up to 25kHz dynamic mode
- Automatic test function can automatically determine whether the test results exceed the set specifications
- Simultaneously perform multiple sets of electronic load modules
- OVP / OCP / OPP / OTP / anti-reverse protection function
- Built-in Ether Net / USB / RS232 communication interface
- Support anti-reverse alarm function

IT8700 series programmable DC electronic load adopts removable modules design, with single frame control 8 channels, and 16 channels with extended mainframe extension transient mode up to 25 kHz , which improves your test efficiency, with high resolution and accuracy. Users can freely choose in the 8 load modules according to the number of channels and power requirements, controlled by mainframe control panel, or controlled by IT9000-PV8700 software via built-in LAN / RS232 / USB interface. IT8700, with adjustable slope, list function, automatic test and other functions, automatic test function can be set to work under CC / CV / CR / CP can be used in the application of R&D and production line. IT8700 has self-diagnosis and comprehensive OVP, OCP, OPP, OTP, etc., ensure the operator safety.

Model	Specification	Size(D*H*W)
IT8731	80V/40A/200W	573*183*85mm
IT8732	80V/60A/400W	573*183*85mm
IT8732B	500V/20A/300W	573*183*85mm
IT8733	80V/120A/600W	573*183*85mm
IT8733B	500V/30A/500W	573*183*85mm
IT8722	80V/20A/250W*2CH	573*183*85mm
IT8722B	500V/15A/250W*2CH	573*183*85mm
IT8723	80V/45A/300W*2CH	573*183*85mm

Matching frame

IT8701P	Two-load module main control unit (including three interfaces)
IT8702	Four-load module main control unit (including three interfaces)
IT8703	Four-load module expansion unit

*1: The total power of dual channel for IT8722/IT8722B is 300W, if the two channel of IT8722/IT8722B work at the same time, need to meet: $50W \leq PCH1 / PCH2 \leq 250W$ and $PCH1 + PCH2 \leq 300W$

*2: IT8700 modules should be equipped with IT8701/IT8702 mainframe

*3: Interface of mainframe: RS232, USB, LAN.

*4: For any GPIB interface option request, check with ITECH for availability.

*5: IT8702 only can work with 1pc of IT8703.

Freely configurable modular system architecture

IT8700 adopts modular design, which has a high-performance microprocessor in every module and mainframe. It has high measurement speed because of parallel architecture. The mainframe controls each models synchronously and show the testing values in real time.

Dynamic power distribution function

Usually, one module require high power while another require low power in battery testing. IT8722/IT8722B has dynamic power distribution function, that means within 300W, any channel which power over 50W and less than 250W, the power can be distributed freely, one module can be used as multiple standard modules.

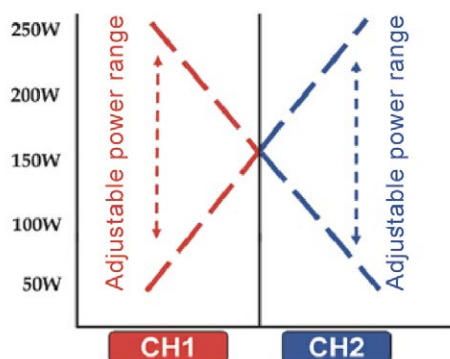

With ITECH test system

ITS5300 battery test system can be formed by IT8700, ITECH power supply, battery resistance tester and temperature data logger, which makes hundreds of channels run at the same time, record voltage and current waveforms in real-time. Test data can be exported to EXCEL.

IT8700 can also equip with ITECH AC and DC power supply, relay card, I / O Card, DSO card to set up ITS9500 power supply test system, which achieves multi-supply modules simultaneously test or multiplex output AC / DC or DC / DC power supply module test.

IT8700 with IT9380 software can achieve multi-channel solar cell test, the test interface can be switched freely, support the sampling time settings, export test data, and with up to 50KHz I-V sampling rate, achieving high efficient and fully automated testing for solar panel.

Peak voltage, peak current measurement function

Dynamic current testing of switching power supply often requires oscilloscope to capture instantaneous voltage and current waveforms to obtain the value of the peak voltage V_{pk} and the peak current I_{pk} . IT8700 is with digital data acquisition function, users can easily get the values of V_{pk} and I_{pk} without oscilloscope.

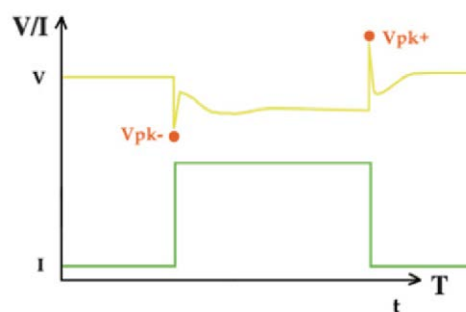

High resolution and accuracy

IT8700 has the best product features with 0.1mV / 0.01mA resolution and 50kHz measurement speed, so that your test is fast and accurate.

High power density

Maximum power density - 600W single module with ITECH advanced cooling technology, making IT8700 has ultra-high power density, 4u height up to 2400W.

Auto test

This function can be applied in the automated production test, users can set measurement mode and pull load value of each step for panel or PC software, and the upper and lower limits of test parameters, and display whether the test results have exceeded the set specifications.



IT8400 High performance DC electronic load

Fast double power loading < 3s

25kHz dynamic loading available for 1200V models

3 current ranges, max.40uA resolution



IT8400 high-performance DC electronic load has two voltage levels, 600V and 1200V. It supports master-slave connection in parallel with power from 6 kW to 600 kW, and is capable of fast double power loading. It has three current readback ranges with a resolution of up to 40uA. IT8400 has faster loop response and current rising and falling speed. It supports up to 8 working modes. It also has dynamic mode, List, OCP, OPP test, automatic test and battery test functions. IT8400 has built-in CAN, LAN, GPIB, USB, RS232 and analog interfaces, suitable for remote control and system building. In addition, the full protection function makes it well matched with the test of fuel cell, power battery discharge, DC charging pile, BOC, power electronics, solar, automotive high-voltage components, DC-DC, motor and so on.

Feature

- Max.Voltage : 1200V
- Current range: 1.5A~15,000 A
- Power extended to 600 kW through master-slave connection in parallel
- High-precision three current measurement ranges with resolution up to 40uA
- Fast double power loading capability (<3 s)
- 25kHz fast dynamic mode, current rising and falling time is adjustable
- Provide 8 working modes: CC, CV, CR, CP, CC+CV, CV+CR,CR+CC, CP+CC
- 1 kHz continuous sampling rate
- List programming
- The battery discharge function is used to test energy storage devices such as batteries and super capacitors
- CV loop speed is adjustable to match different power supplies
- 500 kHz voltage and current sampling rate
- Time measurement, OCP/OPP test short circuit simulation, automatic test
- Soft start and soft shutdown to prevent voltage fluctuations during on/off
- I-monitor function
- Full protection: OVP, UVP, OCP, OPP, OTP, current oscillation protection, current limit, power limit, reverse alarm, etc.
- Power-off retention memory function, recording up to 100 groups data
- Independent control, easy to maintain and install.
- Built-in standard LAN, USB, RS232, GPIB, CAN and analog, IO interface
- LabVIEW driver and SCPI protocol

IT8400 High performance DC electronic load

Electronic Load

Input	600V	1200V	Height
6 kW	IT8406-600-150	IT8406-1200-75	4u
12 kW	IT8412-600-300	IT8412-1200-150	8u
18 kW	IT8418-600-450	IT8418-1200-225	15u
24 kW	IT8424-600-600	IT8424-1200-300	27u
30 kW	IT8430-600-750	IT8430-1200-375	27u

Input	600V	1200V	Height
36 kW	IT8436-600-900	IT8436-1200-450	27u
42 kW	IT8442-600-1050	IT8442-1200-525	37u
48 kW	IT8448-600-1200	IT8448-1200-600	37u
54 kW	IT8454-600-1350	IT8454-1200-675	37u

* This information is subject to change without notice

Application

Automotive electronics

DC charging station, OBC, DC-DC, generator, motor, fuse, relay, MCU, power electronics devices, sensor.

Energy storage

Battery, fuel cell, super capacity

Solar

PV modules, power optimizer

Electric and electronics devices

UPS, motor, power semiconductor



Fast loading with double power

The input voltage of IT8400 DC electronic load can reach 1200V. It has a fast double power loading capacity and is available for all models from 6kW to 600kW. You do not need to select the model according to the maximum power during the actual test, which can greatly save your costs.

The input over power and loading time are relevant with the temperature of the electronic load. For example: below 30°C, IT8400 supports double power loading within 3 seconds. This makes it suitable for instantaneous high-power discharge tests of motors and batteries. For example, simulating the starting of a DC motor, simulating the transient overload characteristics of some power supplies, or instantaneously discharging a high-power battery or fuel cell.

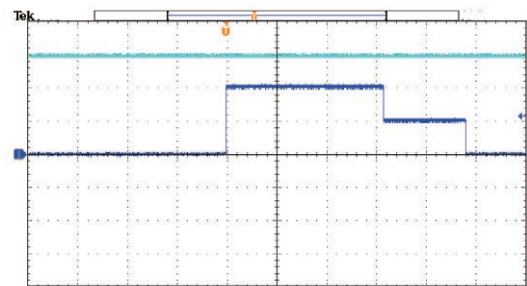

AC impedance test of fuel cells

IT8400 can be used to check the output impedance of fuel cells. Wire according to the figure below, it should be noted that:

1. Use 4-wire Kelvin wiring to more accurately measure fuel cell output voltage and eliminate voltage drops on power lines. A two-wire system can measure lower voltages.
2. Twist the remote Sense wires together (twisted pair) and separate them from the source leads to reduce noise inductive coupling in the sense wires.
3. Keep the test lines as short as possible to reduce transmission line ringing in case a step load change occurs.

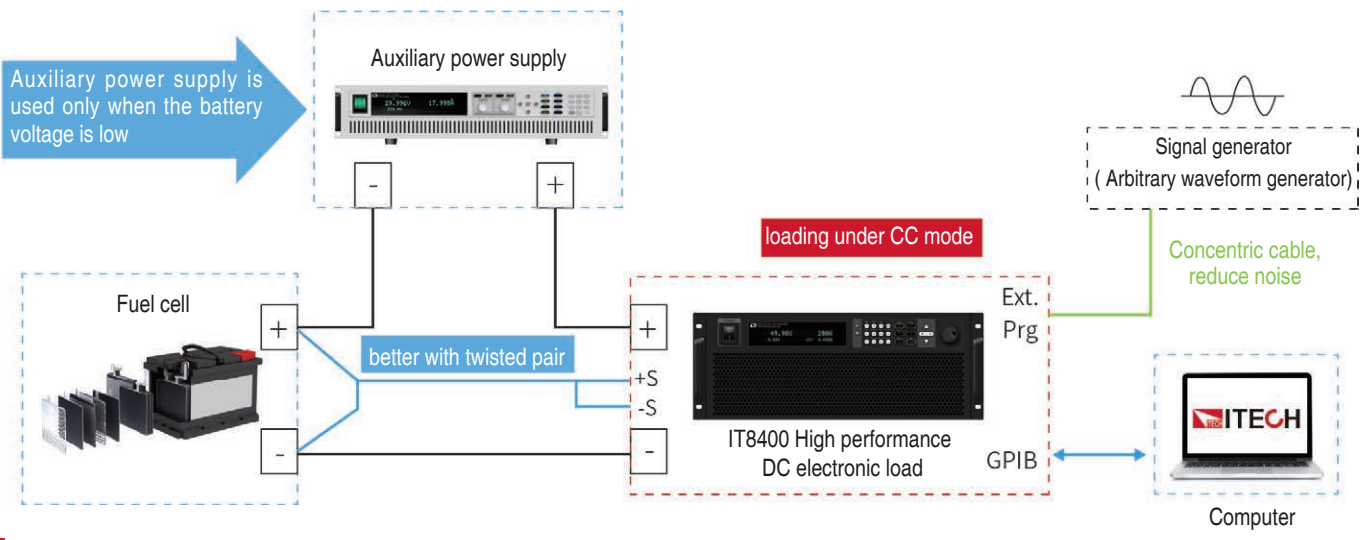

Higher current rise and fall speed and dynamic speed

Dynamic testing is one of the necessary test items for power supplies. The dynamic mode of IT8400 can be used to measure it. Set the current level, time, rising and falling slope and repeat times, and then you can check if the power supply still works stably when the load current is changed stepwise.

IT8400 supports the programmable dynamic loading mode with 25kHz. The minimum current rise and fall time is 15us. When the loading current changes continuously, the internal monitoring and circuit can minimize the current waveform distortion. So it is well used for transient response test of switching power supply and dynamic discharge test of battery.

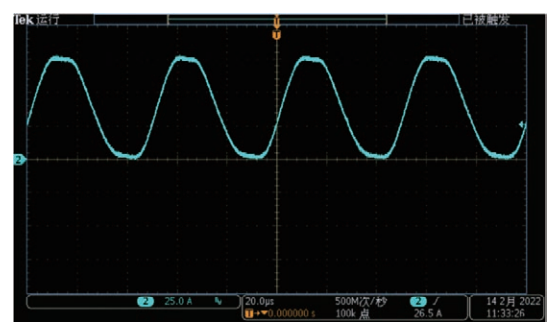

Multiple built-in communication interfaces



IT8400 DC electronic load has built-in standard LAN, USB, RS232, CAN, GPIB, analog interfaces. It also provides Labview driver and free software IT9000. In addition, it supports SCPI protocol. It is available for power extension, computer or PLC remote control, system building etc.

3 Current measurement range

All models of IT8400 series have 3 current measurement ranges. For example, the 1200V, 6kW model, its current can reach 1.5A. In addition, the high resolution (40uA at most) and high accuracy (1.5mA at most) enable it to be widely used in the tests such as solar, power semiconductor devices, automotive electronics and so on.

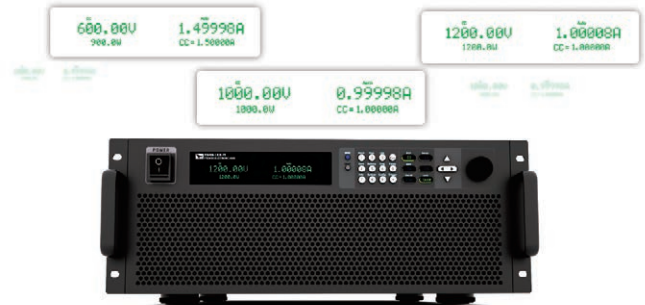

8 Working modes

IT8400 series provides eight kinds of working modes such as CC, CV, CR, CP, CV+CC, CV+CR, CR+CC, CP+CC, which can adapt to the test requirements of various occasions. Among them, the CP mode is often used to UPS battery test, simulate the current change when the battery voltage is decaying. It can also be used to simulate the characteristics of the inputs of DC-DC converters and inverters. The CV+CC mode can be applied to the load simulation battery and test the charging station or the car charger. When the CV is working, the maximum loading current is limited. CR+CC mode is commonly used in the testing of voltage limiting, current limiting characteristics, constant voltage accuracy, and constant current accuracy of on-board chargers, which

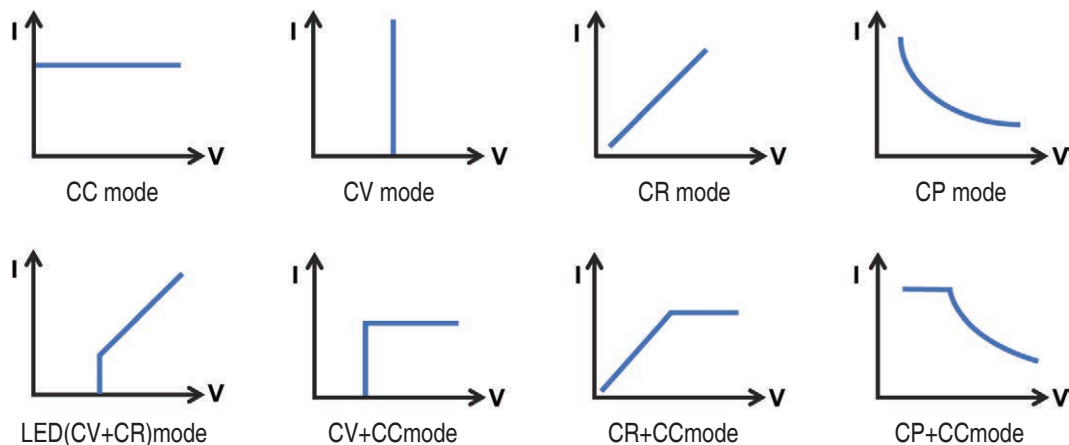

Application

Test of charging station

In the charging station test, when the load works under CV mode and has reached 700V gradually, because the current increases faster (in order to make the load quickly stabilize at 700V), it is easy to trigger overshoot current protection of the charging station.

At this time, we can set the I-limit in the CV+CC mode to make sure that the internal current won't exceed the overshoot value, which can effectively deal with the above issue.

CV+CC mode
(I-limit)
No current overshoot

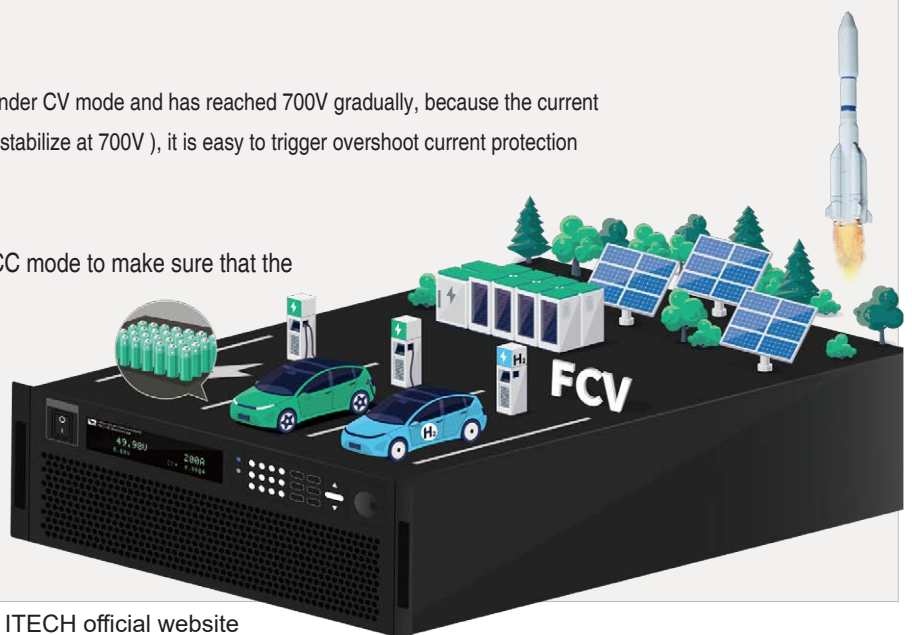



List function

Testing of power supplies or batteries often requires complex simulations of operating conditions with different loading currents. The List mode of IT8400 can help to realize it.

In addition, IT8400 DC electronic load also allows programming by both front panel and computer. It synchronizes the triggering of internal or external signals, which makes it easy for system integration and remote control.

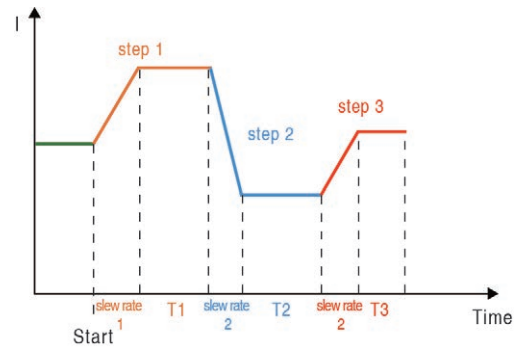
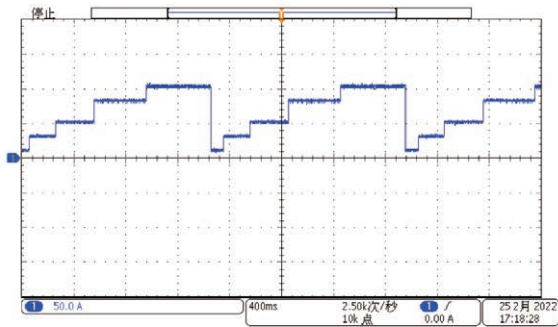

OCP, OPP Tests

OCP and OPP are mainly applied in over-current and over-power point tests of the lithium-battery protection board and power modules. For power supplies, OCP and OPP are designed to guarantee the user's safety and to reduce damage rate. IT8400 DC electronic load can automatically judge the test result according to the set specifications, so the users can save much time in verification of design and production system.

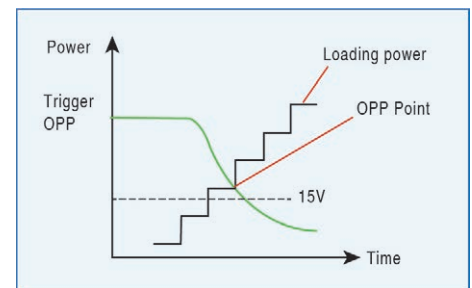

10kHz analog

IT8400 series electronic load has analog control interface, which can be used for industrial control or parallel Expand load power usage.

When used for industrial control, use the 0~10V output from PLC to control the 0~100% full-scale change of the load. Compared with the real-time control of the host computer, the response time is faster, up to 10μs, the single step time is less than 10ms, and the accuracy is acceptable. up to 1%. At the same time, it also has the advantage of unlimited steps. It can be used for battery testing of various complex waveforms, and also for impedance analysis of fuel cells test.

When used for parallel expansion of load power, the analog interface can be used for parallel differential analog control

Compared with the traditional independent LAN port parallel communication, the data is more stable and reliable.

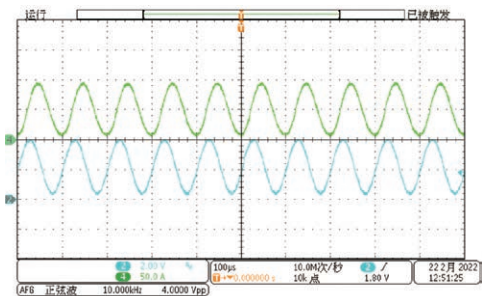

Full protections

To avoid instrument damages by incorrect operations or abnormal ambient surroundings, IT8400 provides OVP, OCP, OPP, over heat protection, anti-reverse protection, current limit protection, power limit protection, and etc. When abnormal, IT8400 will immediately stop working to ensure the DUT safety.

OVP

OCP

OPP

Over heat protection

Anti-reverse protection

Current limit protection

Power limit protection

Master-slave paralleling, flexible power configuration

IT8400 series supports master-slave connection in parallel and equalized current. It also supports parallel connection between the units with different power and same voltage. After paralleling connection, all functions of the stand-alone can be realized, including working in CV mode, maximum paralleling up to 600kW. The stand-alone can also work independently and the power configuration is more flexible. It adopts analog and digital wiring separately, which ensure the stable performance of the units.

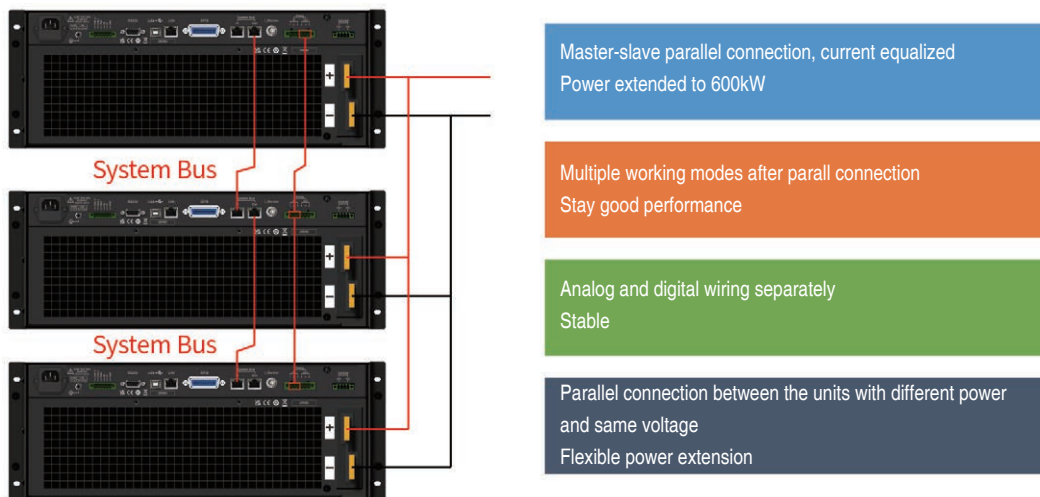

Battery discharge function

IT8400 DC electronic load has battery discharge function, and can perform discharge test under CC, CR, or CP mode. IT8400 can set 3 battery cut-off conditions: voltage, capacity and time. Whenever met any condition, it will automatically stop test. During the test, the battery's voltage, time and already-discharged-capacity can be checked. It can be used in the battery life and reliability test.

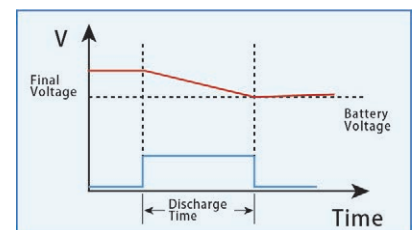
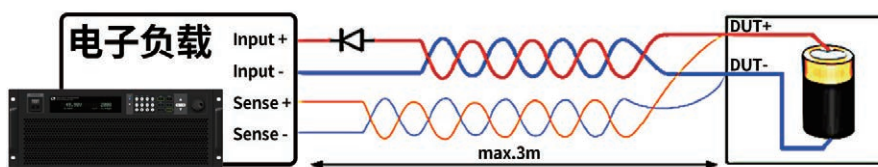

Battery discharge function

DUT: Lithium-ion battery, battery, fuel cell, super capacity

Advantages:

- Power ranges from 6kW to 600kW, voltage 600V/1200V
- Power extended in parallel connection
- Battery discharge cut-off condition: voltage, capacity, time, help to analyze the decay of battery capacity
- List programming and analog help to simulate multiple waveforms
- 25kHz dynamic response, fast current rise and fall
- Analog dynamic response with 10kHz, no limit for steps, the dynamic loading is good for AC impedance test of fuel cell
- 10kHz continuous V-I sampling for battery discharging
- Built-in GPIB, LAN, USB, CAN interface, support SCPI, LabVIEW, can be equipped with ITS5300 battery test system

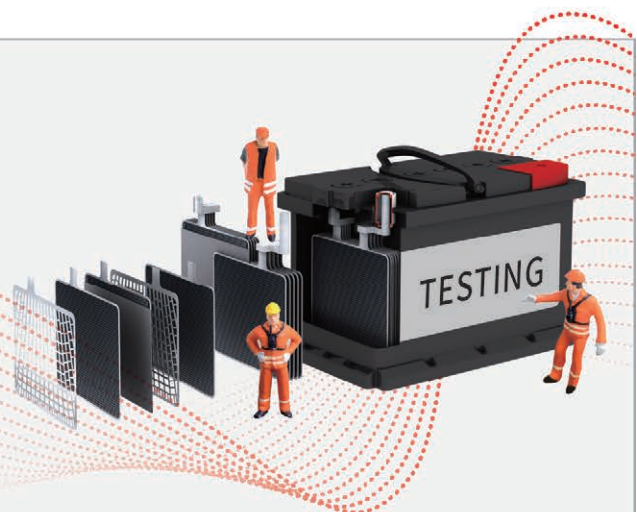



IT8900A/E series high performance high power DC electronic load

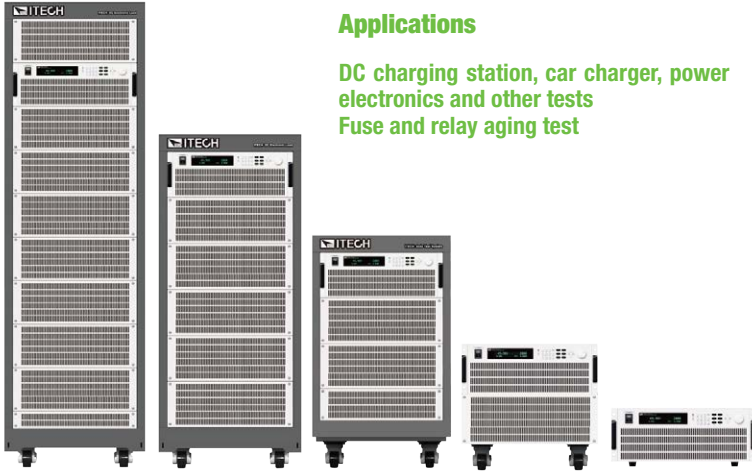

Applications

DC charging station, car charger, power electronics and other tests
Fuse and relay aging test

Feature

- Stand-alone input power: 2kW, 4kW, 6kW, 12kW, 18kW, 24kW, 30kW, 36kW, 42kW, 48kW, 54kW
- Voltage range: 150V, 600V, 1200V
- Current range: up to 600A for 4u modules (up to 2400A for 27u racks)
- Master/slave paralleling control, maximum power expands to 384kW
- Multiple operating modes: CC, CV, CR, CP, CC+CV, CV+CR, CR+CC, CP+CC*1
- Transient over-power loading capability*3
- Adjustable CV loop speed, match different power supplies
- 30kHz high-speed dynamic mode, adjustable current rising and falling time*2
- 500kHz high-speed voltage and current sampling rate
- Time measurement, battery discharge test function
- Short circuit simulation, automatic test function
- Soft start and soft stop prevent voltage fluctuations at on/off
- Timing control list programming
- I-monitor
- Built-in LAN, USB, RS232, GPIB, CAN, external analog control interface
- OCP/OPP test function
- High-precision voltage and current measurement
- Protection functions: OVP, OCP, OPP, OTP, current oscillation protection, limited current protection, limited power protection, reverse alarm protection etc.
- Up to 100 groups' memories, with power off memory function
- Independent master unit control for easy maintenance installation

*1 IT8900E only supports CC, CV, CR, CP operation mode

*2 30kHz is only suitable for 150V models

*3 Only IT8900A have

IT8900A/E series high performance high power DC electronic load provides three voltage ranges 150V/600V/1200V, stand-alone power from 2kW to 54kW. IT8900A/E series, with ultra-wide voltage and current range, controlled by an independent master unit. The power expands to 384kW by master-slave paralleling. Ultra-high power density, 6kW is with only 4U height. IT8900A/E series has eight (A series) / four (E series) working modes, faster loop response and current rising and falling speed, as well as dynamic mode, OCP test, OPP test, automatic test and battery test functions. Built-in CAN, LAN, GPIB, USB, RS232 and analog interfaces, etc., IT8900A/E series has comprehensive protection function, which can be applied to power battery discharge, DC charging station, on-board charger (OBC), power electronics and other power electronics products.

High power density, small size

IT8900A/E series adopts high power density design, the size is half of the conventional electronic load, and the weight is 1/3 of the conventional electronic load.

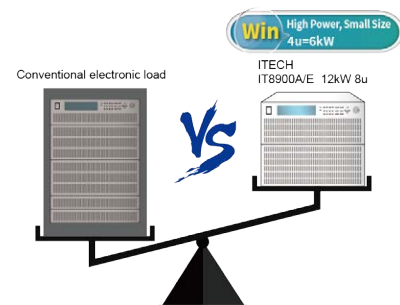

Dynamic and List function

The dynamic mode and list mode of the IT8900A/E series can all be performed in the CC mode. By editing the step width and slope of each step, a variety of complex sequences can be generated, allowing the user to complete various tests with loading wave-forms. And under CC mode, IT8900A/E can set the rising and falling speed.

input parameter	150V	600V	1200V	Height
2kW	IT8902A/E-150-200	IT8902A/E-600-140	IT8902A/E-1200-80	4u
4kW	IT8904A/E-150-400	IT8904A/E-600-280	IT8904A/E-1200-160	4u
6kW	IT8906A/E-150-600	IT8906A/E-600-420	IT8906A/E-1200-240	4u
8kW	/	IT8904A/E-150-560	/	8u
12kW	IT8912A/E-150-1200	IT8912A/E-600-840	IT8912A/E-1200-480	8u
18kW	IT8918A/E-150-1800	IT8918A/E-600-1260	IT8918A/E-1200-720	15u
24kW	IT8924A/E-150-2400	IT8924A/E-600-1680	IT8924A/E-1200-960	27u
30kW	IT8930A/E-150-2400	IT8930A/E-600-2100	IT8930A/E-1200-1200	27u
36kW	IT8936A/E-150-2400	IT8936A/E-600-2400	IT8936A/E-1200-1440	27u
42kW	IT8942A/E-150-2400	IT8942A/E-600-2400	IT8942A/E-1200-1680	37u
48kW	IT8948A/E-150-2400	IT8948A/E-600-2400	IT8948A/E-1200-1920	37u
54kW	IT8954A/E-150-2400	IT8954A/E-600-2400	IT8954A/E-1200-2160	37u

Ultra-wide voltage and current input range

IT8900A/E series has ultra-wide voltage and current input range, covering a variety of existing models, meeting the requirements of high current, low voltage or high voltage, low current.

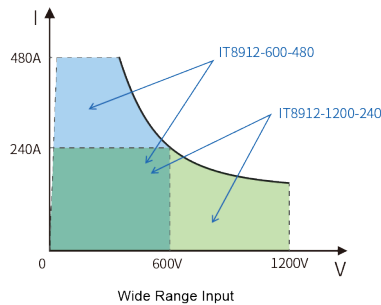

Eight working modes

IT8900A series provides eight kinds of working modes such as CC, CV, CR, CP, CV+CC, CV+CR, CR+CC, CP+CC, which can adapt to the test requirements of various occasions. Among them, the CP mode is often used to UPS battery test, simulate the current change when the battery voltage is decaying. It can also be used to simulate the characteristics of the inputs of DC-DC converters and inverters. The CV+CC mode can be applied to the load simulation battery and test the charging station or the car charger. When the CV is working, the maximum loading current is limited. CR+CC mode is commonly used in the testing of voltage limiting, current limiting characteristics, constant voltage accuracy, and constant current accuracy of on-board chargers, which prevents over-current protection of on-board chargers.

Master-slave paralleling, flexible power configuration

IT8900A/E series have master-slave paralleling and equalized current. IT8900A/E series support cabinet paralleling under different power and same voltage. After paralleling, all functions of the stand-alone can be realized, including working in CV mode, maximum paralleling up to 384kW. The stand-alone can also work independently and the power configuration is more flexible. The paralleling machine adopts analog and digital wiring separately, and the performance of the paralleling machine is more stable.

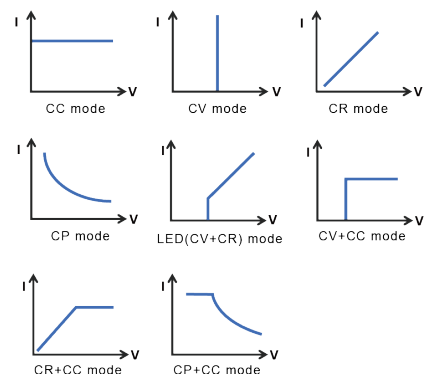
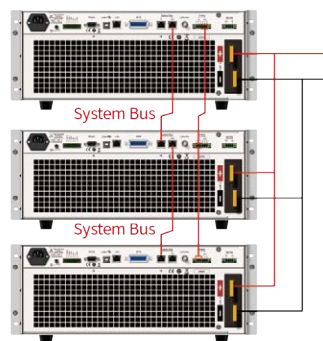

Battery discharge function

IT8900A/E series electronic load has battery discharge function, and can perform discharge test under CC, CR, or CP mode. IT8900A/E can set 3 battery stop conditions: voltage, capacity and time. Whenever met any condition, it will automatically stop test. During the test, users can observe battery's voltage, time and already-discharged-capacity.

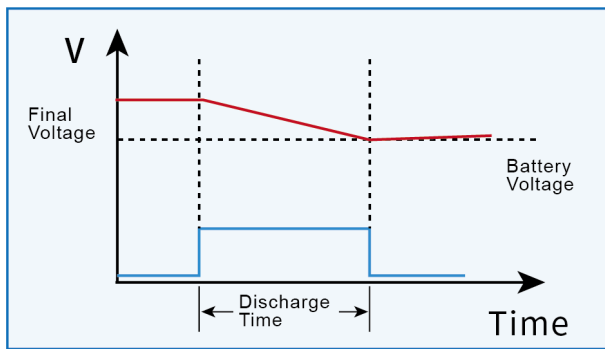
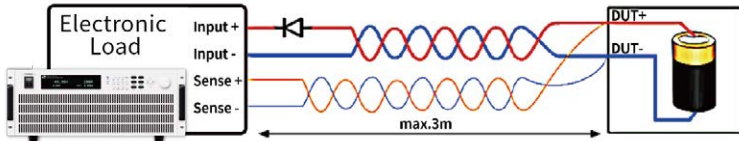

Dynamic mode up to 30kHz

IT8900A series electronic load (150V model) has dynamic mode* with up to 30kHz, the upgrade of the integrated internal structure has greatly improved the loop response and stability. IT8900A can be applied to the transient response test of switching power supplies and can also test transient high current tolerance of DC-DC converters and batteries.

* IT8900E dynamic response is 10 kHz

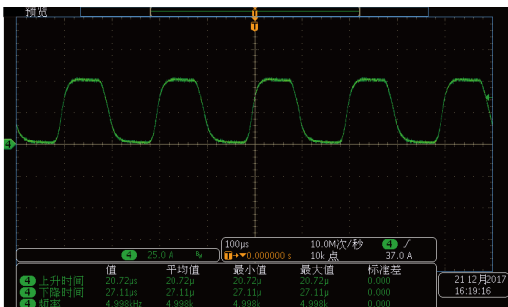

IT8906A-1200-240
5 kHz dynamic loading 0A-50A

Built-in communication interface

IT8900A/E series electronic load is built-in LAN, USB, RS232, CAN, GPIB, analog interface, supports SCPI protocol. It is suitable for power expansion, computer or PLC remote control, system building and so on.

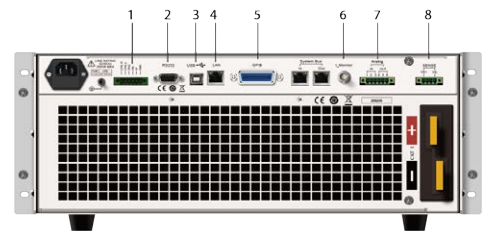

- 1. CAN
- 2. RS232
- 3. USB
- 4. LAN
- 5. GPIB
- 6. i-monitor
- 7. Analog interface
- 8. SENSE

Measure function

IT8900A/E series provides the measurement of rising and falling time of voltage and current. The measurement accuracy is up to 10μs, which is comparable to the high precision oscilloscope. IT8900A/E series can be applied to measure the start-up and shutdown of power modules, holding time, and fuse blowing time. Measurement time is measured by the PC software.

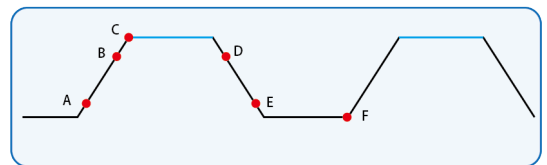

Remarks: from above graph, A and B are arbitrary points of the rising stage, C is one point on the green stage, D and E are arbitrary points of the falling stage.

OCV, OPP Tests

OCV and OPP are mainly applied in over-current and over-power point tests of the lithium-battery protection board and power modules. For power supplies, OCV and OPP are designed to guarantee the user's safety and to reduce damage rate. IT8900A/E series can automatically judge the test result according to the set specifications, so the users can save much time in verification of design and production system.

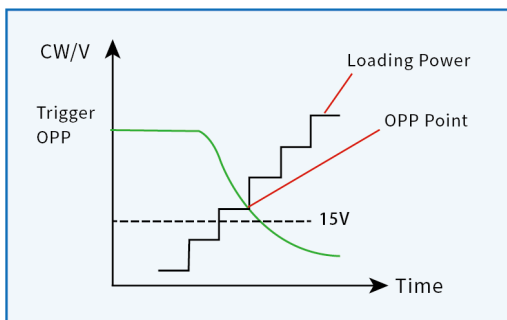

OPP Protection Test

External analog control function

IT8900A/E series electronic load has analog control interface, which can be used for industrial control or expanding load power by paralleling. When IT8900A/E is used for industrial control, using PLC output 0~10V to control the 0~100% full scale change of CC/CV of the load. Compared with the real-time control from PC, the response time is faster and up to 10 μ s, step time is <10ms, accuracy can reach 1%. At the same time, IT8900A/E also has the advantage that the number of steps is not limited. The right picture shows the 0-4.2V sine wave input analog interface, which controls the dynamic loading of the IT8900A 0-100A. The waveform amplitude and phase reduction below 10 kHz are higher. It can be applied to battery tests of all kinds of complicated waveforms, and can also be used for impedance analysis test of fuel cells. When used to paralleling load power expansion, the analog interface can be used for parallel differential analog control interface, which is more stable and reliable than the traditional independent LAN interface parallel communication.

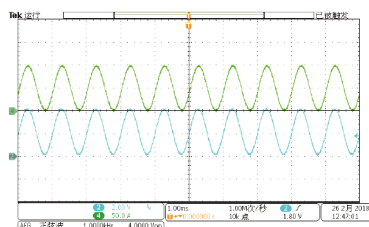

1 kHz sine wave

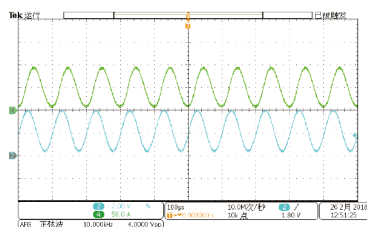

10 kHz sine wave

Full protection

To avoid instrument damages by incorrect operations or abnormal ambient surroundings, IT8900A/E provides soft start, soft stop, current oscillation protection, OVP, OCP, OPP, OTP, current limit protection, power limit protection, and etc. When any abnormal situation, IT8900A/E will immediately stop working to ensure the DUT and personnel safety.



Soft start, soft stop function

IT8900A is with soft start and soft stop function, which can prevent the load from loading too fast, transiently pull down the power supply voltage, or transiently turning off the load to cause power supply voltage surge, that is, the settable on slope, openable off slope function.

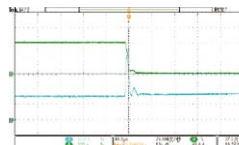

No soft stop function, voltage overshoot

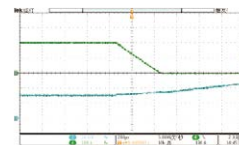

With soft stop function, voltage without overshoot

Transient over power loading capability

IT8900A/E has 2x transient over power capability, which makes load to take over power loading capability in short time. Users can select models as per rated working power of power supply or battery products, instead of maximum power value, and it can extremely save cost. IT8900A/E can simulate motor start-up features, test power supply's transient over load features, and also test the transient high power discharge characteristics of the power battery, ignition battery, etc.

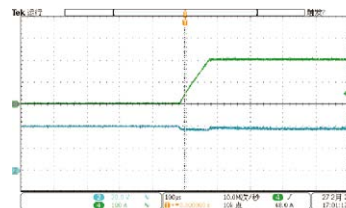

IT8906A-1200-240
rated power 6kW withstand transient 8kW loading



IT8800 High Power DC Electronic Load

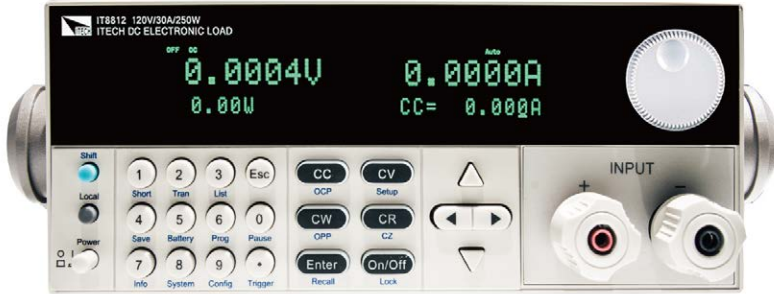

IT8800 series has wide power range 150W-6kW, voltage and current measurement speed up to 50kHz, resolution up to 0.1mV/0.01mA, adjustable measurement current rising speed 0.001A/us~2.5A/us, built-in RS232/USB interface. IT8800 series has wide application fields because of its high performance, it has been applied to LED lighting, aerospace, automotive electronics and other fields.

Applications

High power testing, battery test, power supply test, commercial aviation testing

Feature

- 150W-6kW/120-500V/15-480A
- CV/CC/CR/CW mode
- Remote sense
- Measurement resolution:0.1mV,0.01mA
- Dynamic mode: up to 25kHz
- Adjustable current rising slope: 0.001A/us~2.5A/us
- Measurement speed: up to 50kHz
- Dynamic test, short-circuit test function
- Rotary knob, making the operation more easier
- CR-LED test
- OCP / OVP / OPP / OTP/ Reverse polarity protection
- 100 groups memory capacity
- Power off memory function
- External analog control
- Support VISA/USBTMC/SCPI communication protocol
- Built-in RS232/USB communication interface
- Software monitoring via PC

*For any GPIB interface option request , check with ITECH for availability.

Model	Power	Voltage	Current	Size
T8811	150W	120V	30A	1/2 2U
IT8812	250W	120V	30A	1/2 2U
IT8812B	200W	500V	15A	1/2 2U
IT8812C	250W	120V	60A	1/2 2U
IT8813	750W	120V	60A	3U
IT8813B	750W	500V	30A	3U
IT8813C	750W	120V	120A	3U
IT8814	1.5kW	120V	120A	3U
IT8814B	1.2kW	500V	60A	3U
IT8816	3kW	120V	240A	3U
IT8816B	2.5kW	500V	100A	3U
IT8817	4.5kW	120V	360A	6U
IT8817B	3.6kW	500V	120A	6U
IT8818	6kW	120V	480A	6U
IT8818B	5kW	500V	150A	6U
IT8814C	1.5kW	120V	240A	3U
IT8816C	3kW	120V	480A	3U
IT8817C	4.5kW	120V	600A	6U

Dynamic mode up to 25KHz

Dynamic mode operation allows the electronic load to be switched between the two setting parameters according to the setting rules. Dynamic mode can be used to test the dynamic nature of the power supply, e.g. when the computer disk drive run or stop, the dynamic load mode can simulate the change of operating current.

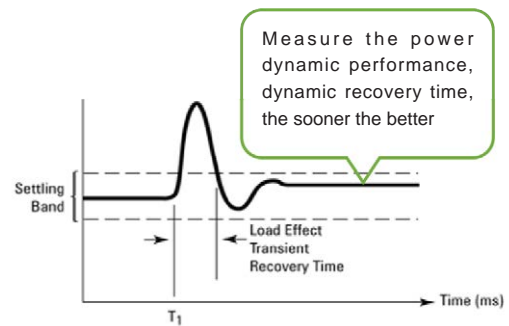

Voltage Rising/Falling time test

IT8800 provides unique measurement function to test voltage rising/falling time. Enter the measure menu under config, and set two voltage points. Then turn on display on timer function, and the rising / falling time is displayed on the screen after completing test.

This test is important for switching power supply testing and fuse testing.

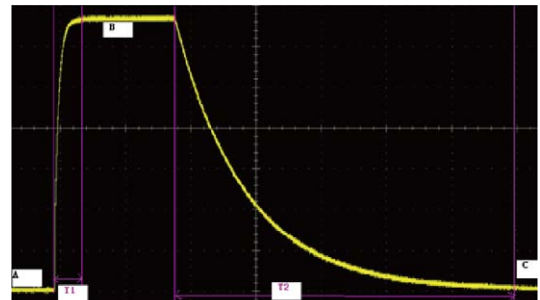

Adjustable Rising/Falling speed of current

List mode allows you to generate a complex current sequence. Moreover, the mode change can be synchronized with an internal or external signal, to accomplish dynamic and precise test. A list file includes following parameters: file name, step counts (range 2-84), time width of single step (0.00002s-3600s), step value and slope. The LIST function can make many kinds of complex sequences, to meet complicated test requirements.

IT8800 electronic load supports panel programming and computer software operation, especially for electronic product development, production line product aging, quality inspection and other complex application environment.

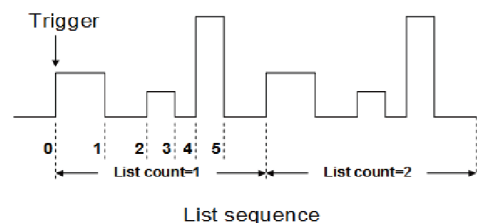

External analog test

IT8800 electronic load can control the loading voltage or current through the EXT PRG (positive and negative) analog port on the rear panel, connect 0-10V adjustable voltage to simulate 0- full-scale input in the EXT PRG terminal, so as to adjust the load input voltage and current value.

Analog control interface meets the control needs of industrial production, users can achieve output voltage control via PLC without the PC control.

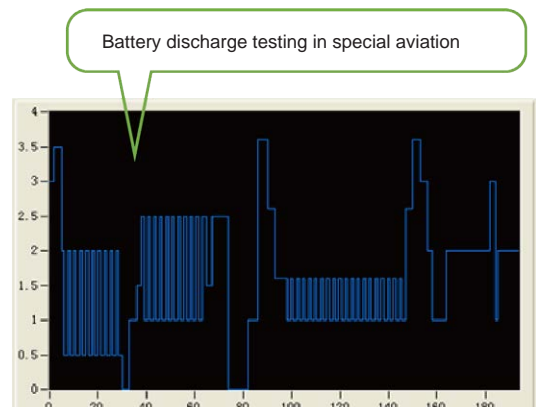



CR-LED test

As we all know the LED constant power supply output waveform usually have large current ripple. This is because the traditional type DC loads can't simulate the actual characteristic of LED driver, its testing current and voltage will shake. Based on traditional CR mode, CR-LED mode of IT8800 series adds the setting item of diode break-over voltage. Only when the input voltage is above the set value, the DC load will start to work. Thus, the IT8800 series can simulate the actual characteristic of LED.

IT8800 unique LED mode can provide LED power drive test, which can be used in LED power simulation.

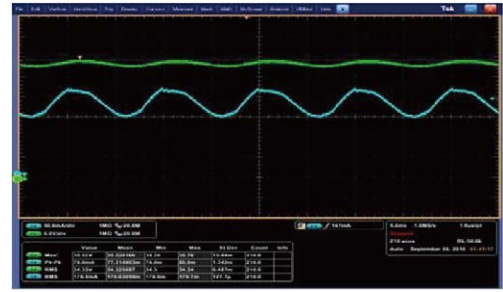

Current monitor

IT8800 series allows the users to monitor actual current through I-monitor terminal. Users could connect an oscilloscope to observe actual current. It will generate at 0-10V analog signal to represent to 0-100% rated current of the front panel.

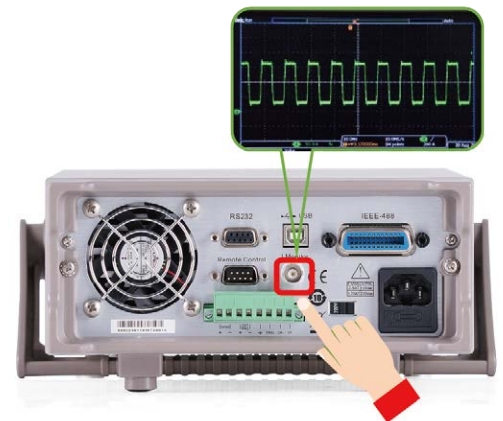

Battery discharge test function

IT8800 series electronic load can respectively set turn off voltage, cut-off capacity, discharge time through the panel and software to be as battery discharge cut-off conditions. The test is automatically stopped when the battery drops to the off voltage or has been discharged to the cut-off capacity or reaches the cut-off time. During the test, you can observe the battery voltage, discharge time and battery discharge capacity.

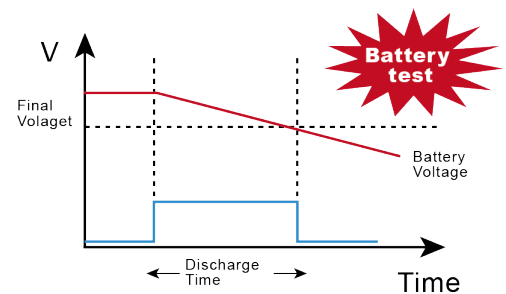

Working mode

The working mode of IT8800 series has CC, CV, CP, CR, and it will make you easy to simulate various characteristics of load, which can save cost greatly. It support OVP, OCP, OPP, OTP, reverse polarity protection and it can set the protection point of current, voltage, and power. In every condition, it will make auditory alarm and cut off the circuit to ensure the safety during test.

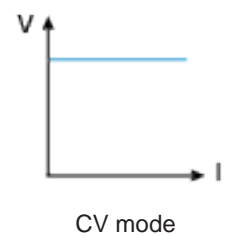
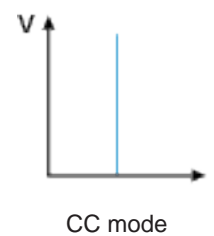

Working mode

IT8800 auto test function can simulate many kinds of testing. It totally can edit 10 test files, and can make connection between one file and another. Also you can choose the condition to stop the test: stop when testing pass or fail. Its adjustable current speed rate of rising and falling can make auto test to simulate kinds of test waveform.

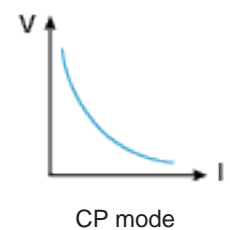
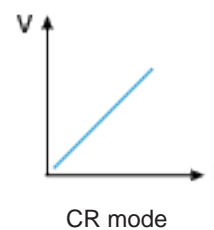

Supporting two loading modes

IT8800 series supports loading voltage setting, and it provides two kinds of load modes. Choosing Living means working goes after status, when choosing latch, it means work load point latch with loading states. It can meet different test requirements.

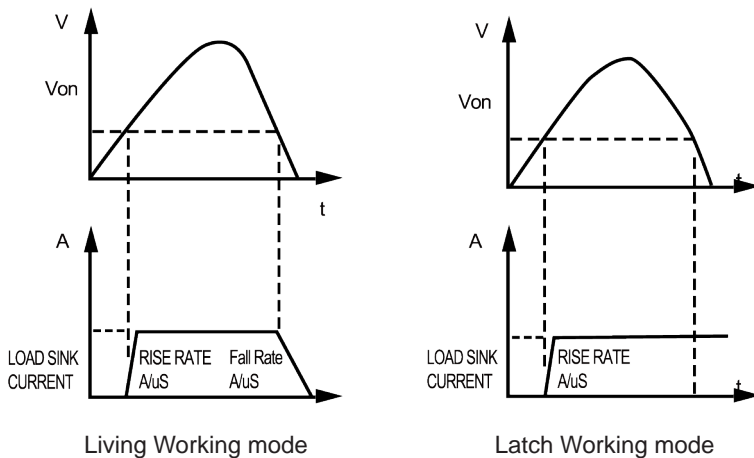

Remote sense function

In CC, CV, CR and CP mode, when load consume high current, it will cause large voltage-drop on the connection wires between tested instrument and terminals of load. Using remote sensing, you can sense the voltage at the power supply's terminals, effectively removing the effect of the voltage drop in the connection wires. In order to avoid the voltage-drop because of too long wires, remote test allows testing on the input terminals to improve the test accuracy.

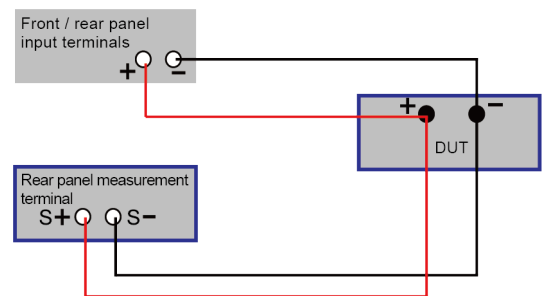

OCP/OPP test

OCP / OPP are mainly used in lithium battery protection board test, power module over current and over power point test. Through the built-in OCP and OPP function, users can test by built-in OCP program start current setting , cut-off current, step current, as well as the duration of each stage current, etc. IT8800 series can automatically capture the OCP point, with the automatic fast function, users can save a lot of verification time when using for design verification and production line system.

Panel operation

It is very convenient to operate the load panel, its shot-cut buttons are as follows: short circuit test, dynamic test, list test, data save, data recall, battery test, auto-test, test stop, test trigger, over current test, over power test.

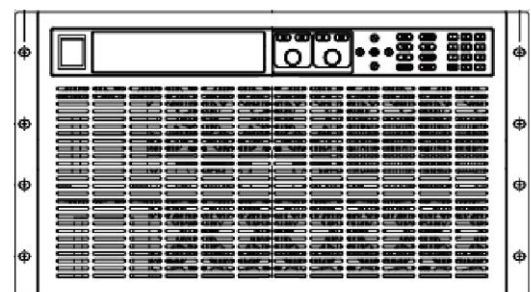
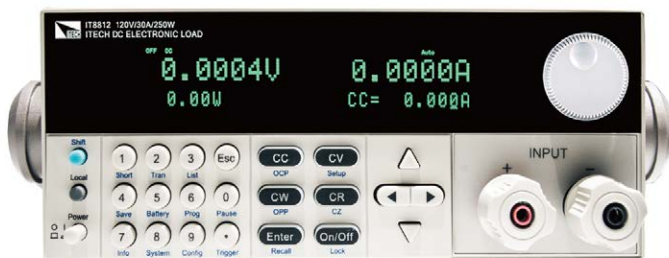

IT8818B (500V/150A/5000W)



Field	DUT	Test items
Automotive electronics	Radio, Car heating seats; Car doors and windows switch	Judge the working current
	Auto-car doors and windows switch	Stability and aging test
	Car central control box	Stability and aging test
Battery	Power Battery	Discharge test
	Cell phone battery	Discharge test
	Solar battery	Discharge, efficiency and other tests
	Mobile power	Discharge test
power supply	Power supply module, power supply	Performance testing
	Regulated power supply, constant current source, constant voltage source	Performance testing
	Switching power supply	Performance testing
	Charger	Performance testing
	Power supply for medical equipment	Energy storage test
	Power supply for military, aerospace equipment, scientific research equipment	Performance testing
	UPS	Energy storage test
LED	LED drive power supply	Electrical parameters and stability test
Power electronic components	MOSFET、IGBT	Performance testing
	Capacitors, rectifiers	Performance testing
	PFC module	Performance testing
Fuse	Fuse	Fuse time test

IT8811/12 Dimension figure 1/2 2U, 150 W~300 W

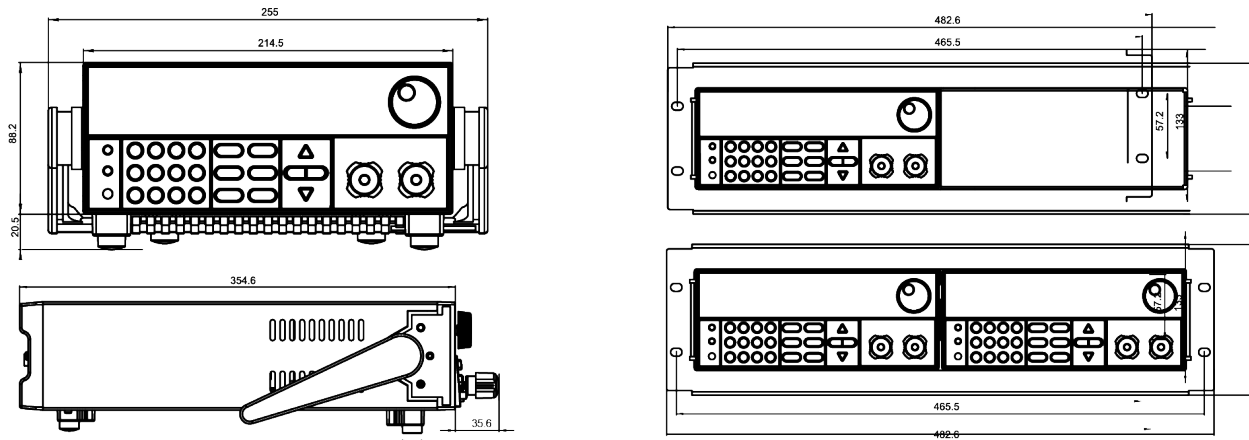

Unit: mm

IT8912E High Accuracy DC Electronic Load



Applications

LED test, power supply test, etc.

Feature

- Up to 20kHz CC dynamic mode
- Voltage resolution up to 10mV, current resolution up to 0.01mA (10uA)
- Voltage/current measurement speed up to 50kHz
- Various working modes CR-LED/CC/CV+CC/CR/CW etc, to protect LED driving power supply.
- Unique CR-LED mode, providing the perfect PWM-LED Driver test solution
- Easy programmable parameter setting, applicable for simulating LED lights with different characteristics
- Automatically judge whether the test results beyond the set specifications according to high / low limit specifications of the test parameters
- Adjustable frequency, duty ratio PWM dimming output port
- I-pp/I-max measurement function can test current ripple and start up surge current of LED constant flow source
- Battery test, auto test, short circuit and dynamic test function
- Built-in USB/RS232 interface, support VISA/USBTMC/SCPI protocol

*For any GPIB interface option request, check with ITECH for availability.

CR-LED mode

The unique CR-LED mode developed by IT8900 series is especially applicable for LED driver test. The user only needs to set the operating voltage, current and coefficient of LED driver to obtain real output parameter of LED driver. Different from universal electronic load, this adopts pure hardware circuit design without software operation by MCU module, thus increasing the speed and stability of CR mode control circuit, solving voltage and current jitter during LED driver test, increasing frequency width and realizing the load dynamic PWM dimming test.

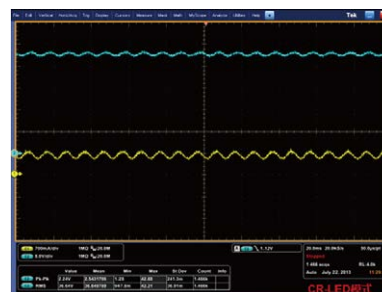

Model	Voltage	Current	Power	Power
IT8912E	500V	15A	300W	1/2 2U



Dynamic test function (Tran)

The operation of dynamic load is periodic switch between two levels and the power supply regulation and transient response are in high and low current levels. With the change of lasting time and ascending and descending rate, the output voltage waveform can be monitored.

Dynamic mode can test transient response time of power, reflecting the ability of the power for keeping itself stable during the step change of load current.

Dynamic test modes can be divided into continuous transient operation, pulsed transient operation and toggled transient operation.

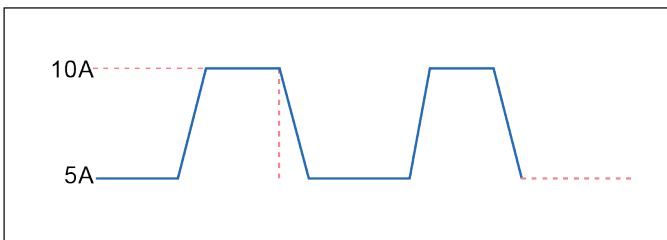

Continuous Transient Operation

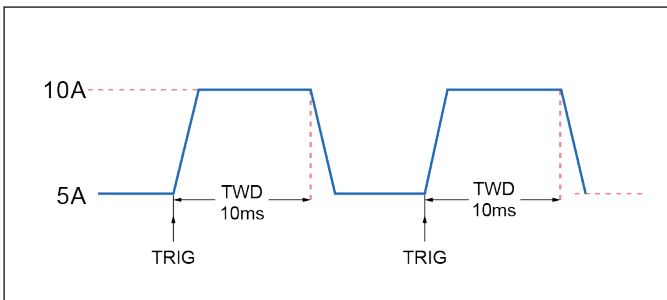

Pulsed Transient Operation

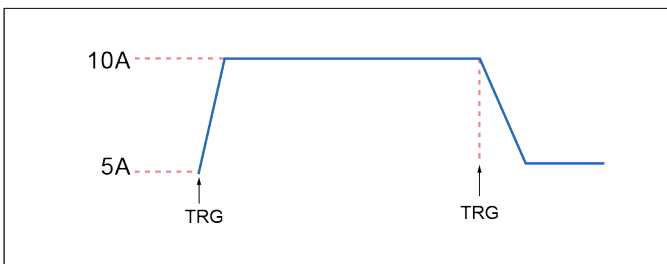

Toggled Transient Operation

CC+CV mode

For CV + CC operation mode, it will be under CV mode when start up, LED driver IC or concatenated current-limiting resistor should be used. When the output current exceeds the rated value and reached constant current interval, CC mode will be triggered for directly driving LED. This CV+CC can be used for various LED configuration models, contributing to the flexibility of system design as well as protection for LED driver source.

PWM dimming test

For LED driver power with complex dimming technology, in addition to the conventional electrical load test, dimming test is needed. In order to realize the dimming test, it is necessary to provide the PWM pulse signal to the corresponding pin. Therefore, signal generator equipment is needed during experiment. In addition to IT8912E itself CR-LED mode, IT8912E also can output external 20Hz ~ 2kHz PWM pulse waveform for dimming features drive source testing, saving cost.

IT8912E Dimension figure

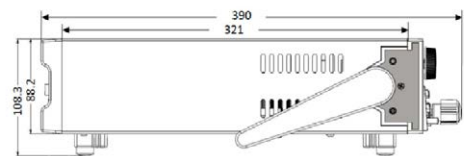
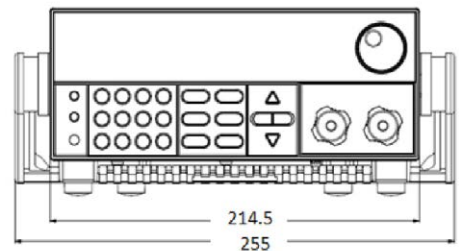

IT7900P High Performance Regenerative Grid Simulator

Applications

fuses, AC-DC power adapter testing, V2G, V2X, EVSE



Adopting advanced SiC technology, the IT7900P regenerative grid simulator can be used not only as a high power AC power supply, but also a four quadrant grid simulator. The full four-quadrant operation, regenerative ability can feedback power to the grid, meet the needs of environmental protection, but also save a lot of electricity and heat dissipation costs. Compact, modular and efficient structure design allows the IT7900P up to 15kVA in 3U single unit, and its power can be extended to 960kVA after master-slave parallel connection. Colorful touch screen with intuitive GUI allows IT7900P to directly define different waveforms. The rich operation modes can meet the test requirement of single-phase, three-phase, inverse-phase and multi-channel. It provides high exibility for testing and can be widely used in many fields such as PV, ESS and EV.

Applications

ESS

PCS energy storage converters, microgrids, home PV energy storage devices

PV

Photovoltaic inverters, power conditioning systems

Scientific research, universities, laboratories, certification bodies

AC-DC power adapter testing, electromagnetic compatibility testing

Power Electronics

Uninterruptible Power Supply System (UPS), AC power supply, inverter Generators, transformers, AC fans

Electronic Components

Circuit breakers, fuses, connectors

EV

V2G, V2X, EVSE, vehicle type converters, electric vehicle power supply



Model	Voltage	Current	Power	Phase	Size
IT7905P-350-30U	350V	30A	5kVA	1Φ	3U
IT7906P-350-90	350V	90A	6kVA	1Φ or 3Φ	3U
IT7909P-350-90	350V	90A	9kVA	1Φ or 3Φ	3U
IT7912P-350-90	350V	90A	12kVA	1Φ or 3Φ	3U
IT7915P-350-90	350V	90A	15kVA	1Φ or 3Φ	3U
IT7930P-350-180	350V	180A	30kVA	1Φ or 3Φ	6U
IT7945P-350-270	350V	270A	45kVA	1Φ or 3Φ	15U
IT7960P-350-360	350V	360A	60kVA	1Φ or 3Φ	27U
IT7975P-350-450	350V	450A	75kVA	1Φ or 3Φ	27U

Model	Voltage	Current	Power	Phase	Size
IT7990P-350-540	350V	540A	90kVA	1Φ or 3Φ	27U
IT79105P-350-630	350V	630A	105kVA	1Φ or 3Φ	27U
IT79120P-350-720	350V	720A	120kVA	1Φ or 3Φ	37U
IT79135P-350-810	350V	810A	135kVA	1Φ or 3Φ	37U
IT79150P-350-900	350V	900A	150kVA	1Φ or 3Φ	37U
IT79165P-350-990	350V	990A	165kVA	1Φ or 3Φ	37U

*Inverting and phase-locking function can achieve higher voltage test

*Please contact ITECH for higher power needs.

*The above specifications are subject to update without notice.

Parameter Features

- Adopt advanced SiC technology
- High power density, up to 15 kVA for 3U
- Voltage can reach 350V L-N
- Master and slave equal flow, parallel machines up to 960kVA *1
- Highly efficient power regeneration
- Comprehensive working modes selectable: single-phase, three-phase, reversed phase and multi-channel, Voltage extension to 200% of rated voltage in inverted mode
- Support LIST/SWEEP/Surge&Sag three waveform modes
- Built-in rich waveform database

Source Features

- Regenerative grid simulator & full 4-Quadrant AC&DC power sources
- Frequency: 16-2400Hz *4
- Power Amplifier function for PHIL applications
- Professional islanding test mode, support R, L, C and active, reactive power settings *7
- Four output modes of AC/DC/AC+DC/DC+AC can be realized
- Multi-channel function, single unit can test 1-3 DUTs at the same time *5
- Programmable output impedance, simulation of real-world impedance Harmonic/inter harmonic synthesis
- Frequency lock and phase lock function to achieve 6 phase& 12 phase power output

- Phase angle 0-360° settable
- Harmonic simulation and analysis function up to 50 times, built-in IEC61000-3-2/3-12 *2
- Can simulate arbitrary waveform output, support CSV file import waveform
- Touch screen design, simple UI interface
- Built-in USB/CAN/LAN /Digital IO interface, optional GPIB/analog & RS232 interface
- Full protection functions including automatic clearing, POVP, watchdog, etc.
- Optional source accessories *3
- Compliance tests incl. LVRT /Phase Jump/Frequency variation/harmonic injection
- Supported regulatory testing include IEC61000-4-11/4-13/4-14/4-28 etc.
- Provide rich trigger configuration, synchronous capture of the voltage waveform of the object to be measured, to achieve data acquisition and simulation functions
- Optional software can help complete the pre-compliance standards test of civil avionics/electrical ships in terms of the multi-national safety regulations. *3

Load Features

- Regenerative full 4-Quadrant AC&DC load
- Frequency: 16-500Hz
- AC mode supports CC/CP/CR/CS/CC+CR/CE multiple operating modes, and CE mode can simulate a variety of circuit topologies such as single-phase rectifier RLC and shunt RLC.
- DC mode supports 9 working modes such as CC/CR/CP/CV
- AC mode supports both rectified and non-rectified modes

*1 For 1U/2U models, max.16 units can be parallel connected, for 3U models max. 64 units can be parallel connected.

*2 Voltage/current harmonic analysis, voltage harmonic simulation in source mode, current harmonic simulation in load mode, fundamental wave \leq 60Hz

*3 Stay tuned

- Adjustable crest factor: 1.414 ~ 5.0
- Support phase shift function in the range of -180° ~ 180° *6
- The unit power factor1 function allows the current waveform to vary with the voltage waveform and the power factor is as close to 1 as possible
- Supporting unloading angle control, 0 - 359° adjustable

*4 In grid simulator and island simulation mode, 16~150Hz

*5 Not available for single-phase models

*6 After the rectification function is turned on, the setting range of the phase shift is restricted by the crest factor

*7 Not available for multi-channel mode

4-Quadrant output

IT7900P series is not only a full four-quadrant power grid simulator, but also a full four-quadrant AC/DC electronic load. It can operate in all four quadrants. The efficient energy regeneration function makes it good for testing the frequency change of grid-connected PV inverters, voltage transients and anti-islanding protection.

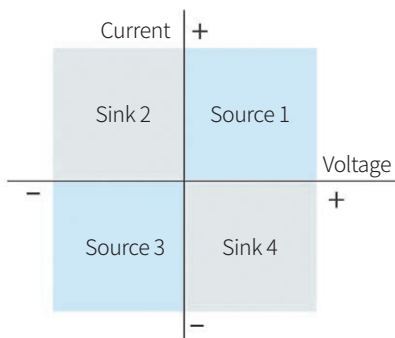

Pre-compliance regulation test

According to industry standards, IT7900P series has built-in regulation standards such as IEC 61000-4-11/4-13/4-14/4-28, IEC61000-3-2/3-12. These regulations can be recalled directly. You can also customize the test items required by regulations too.

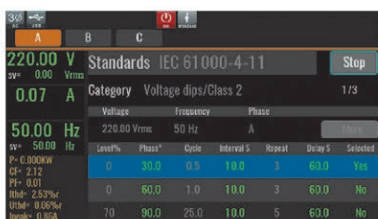

All in one unit

IT7900P series integrates 3 products, a grid simulator (IT7900), an AC/DC power supply (IT7800) and a regenerative AC/DC load (IT8200).

Professional Anti-islanding Test Mode

Anti-islanding protection is one of the must-test items for grid-connected inverters. IT7900P series has built-in anti-islanding protection test function, which allows testers to set the active power of resistor R, the reactive power of inductor Q and capacitor C, and also set resistor R, inductor Q, and capacitor C to simulate the inter-network resonance and test the anti-island protection function of grid-connected inverter. IT7900P island test mode can simplify the test process, improve test efficiency, and complete the test of the anti-islanding protection function in the process of grid-connected inverter research and development test, factory inspection, etc.

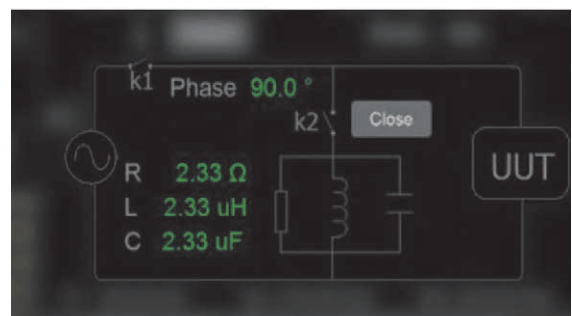



AC/DC load conditions emulation

DC load mode

- Constant Voltage (CV)
- Constant Current (CC)
- Constant Resistance (CR)
- Constant Power (CP)
- CC+CV
- CR+CV
- CP+CV
- CC+CR
- CP+CV+CR+CC

AC load mode

- Constant Current (CC)
- Constant Resistance (CR)
- Constant Power (CP)
- Constant apparent power (CS)
- CC+CR
- CE RLC

Single rectified RLC
Parallel RLC
.....

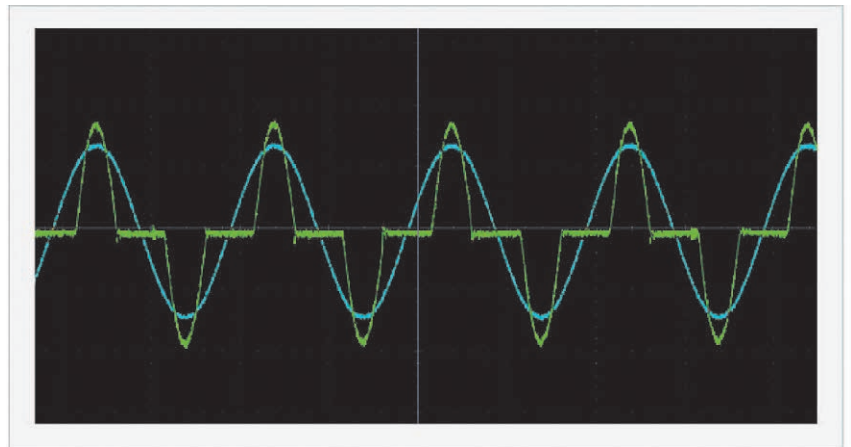
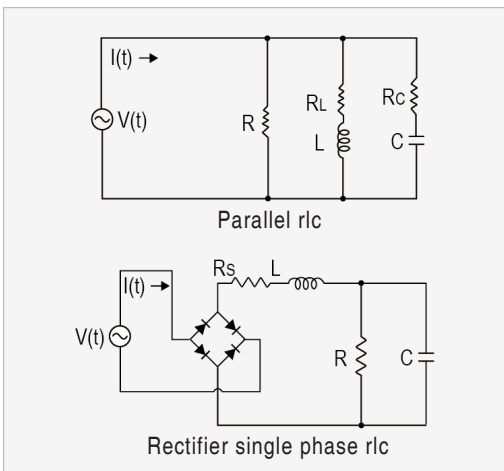

IT7900P AC electronic load can enable the 'Rectified' function in AC mode, so that the load works in the first and third quadrants to ensure that the voltage and current flow always in the same direction. At this time, full wave, positive half wave, or negative half wave can be freely selected.

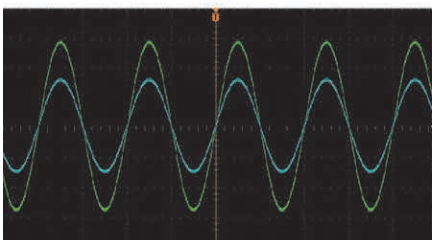

full wave

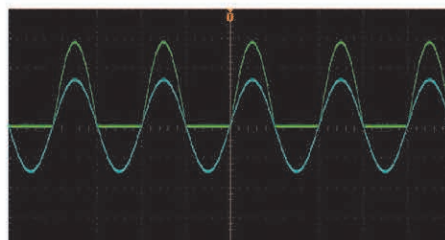

positive half wave

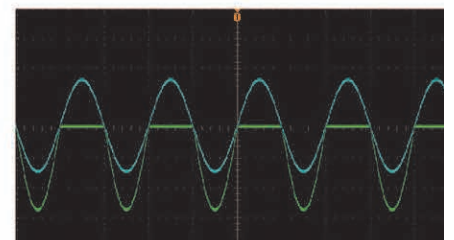

negative half wave

Full 4-Quadrant Power Amplifier

The IT7900P series regenerative grid simulator can be used as a power amplifier to complete power hardware in the loop (PHIL) applications for microgrids, energy storage and new energy vehicles. The digital I/O or a standard suite of analog signal can be input via an external analog interface (optional) and then amplified without distortion to a real power waveshape with an external analog response time of less than 200us.

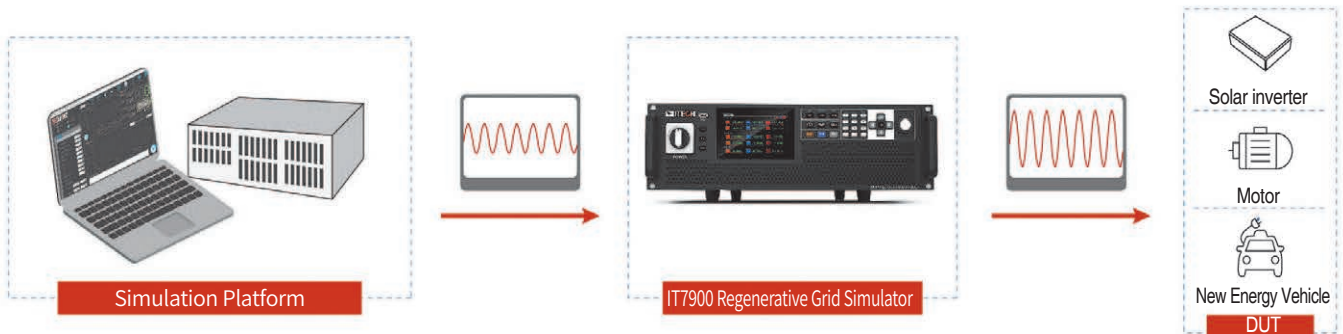

CF 1.414-5.0

The crest factor indicates the extreme peaks of the waveform. For applications that require a pure sine wave, it is desirable to have a CF value of the load current waveform of 1.414 or as close as possible. However, in practical applications, the peak shape of the current waveform of the load may become very sharp and its CF is often higher than 1.414. At this time, the starting point of the sine wave starts to shift from 0 degrees to the positive degree. So you need to correct the waveform. The Crest Factor of the IT8200 can be adjusted from 1.414 to 5.0, and it also allows to set the phase shift angle from -90° to 90° , correct the resulting amplitude, and keep the RMS unchanged. This enables more accurate simulation of field test conditions to ensure the reliability of the unit under test (UUT).

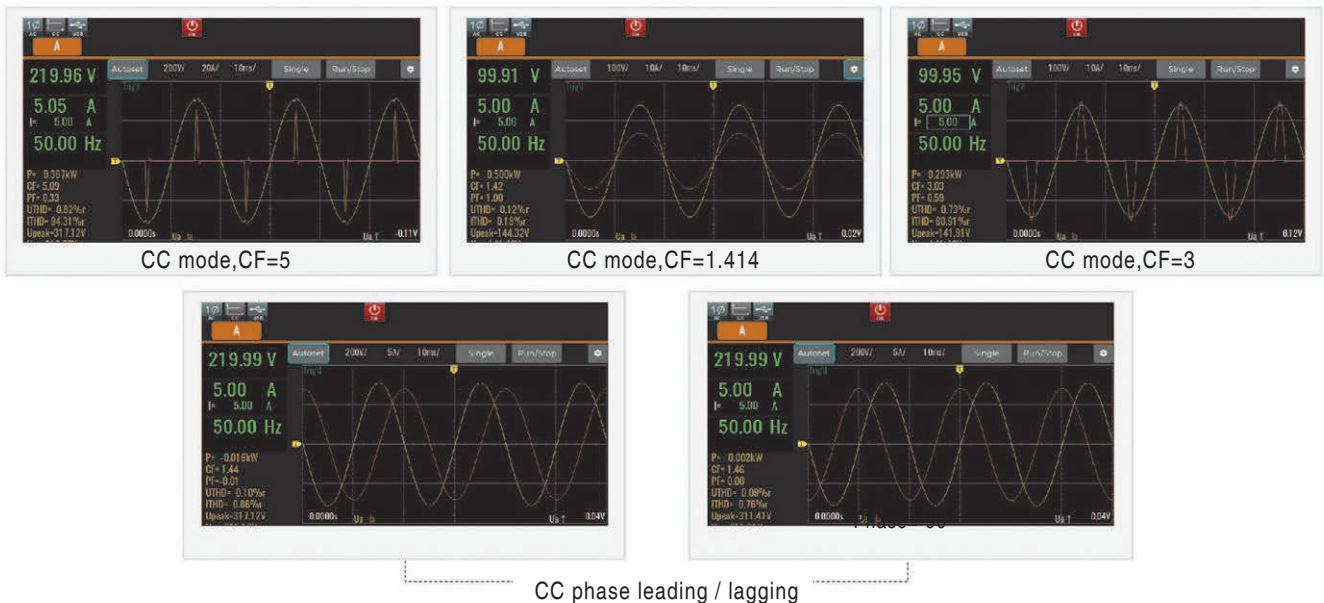

Frequency lock/phase lock function, multi-phase output or high voltage output

IT7900P series can realize frequency locking and phase locking between power supplies through optical fiber, simulating 6-phase and 12-phase power output. It can not only keep the set value updated synchronously, but also has multi-phase protection to meet the complex AC test requirements. This also helps to realize high-voltage tests up to 700Vrms 3 phase. Via the digital IO interface, it can also be used for simple multi-phase system applications.

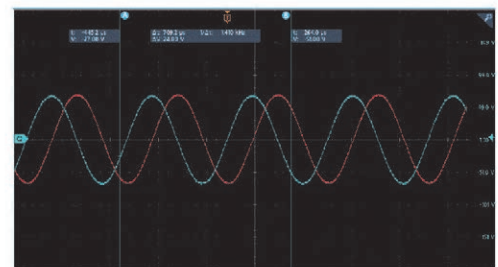

phase lock, 2400Hz

Built-in various type of distorted waveforms

Thanks to the function of large data recording, IT7900P series is capable of recording up to 7 hours of continuous data at short intervals (fastest: 100ms). And it's easy to view the complete curve generating from the start to the end of the test. There are six curves that can be displayed at the same time at most. In addition, you can slide the vernier calipers on the screen to check the exact data at a particular point in the current trend curves. It is useful for analyzing errors during test for a long time or inflection points during loading, etc. Besides, you can export the test data for further analysis by front panel USB interface.



Data record

Thanks to the function of large data recording, IT7900P series is capable of recording up to 7 hours of continuous data at short intervals (fastest: 100ms). And it's easy to view the complete curve generating from the start to the end of the test. There are six curves that can be displayed at the same time at most. In addition, you can slide the vernier calipers on the screen to check the exact data at a particular point in the current trend curves. It is useful for analyzing errors during test for a long time or inflection points during loading, etc. Besides, you can export the test data for further analysis by front panel USB interface.

Intuitive software interface

IT7900Pseries provides free PC software PV7900P with an intuitive GUI. Meanwhile, it allows remote control, even the ATE models without display screen can be programmed, communicated and monitored.

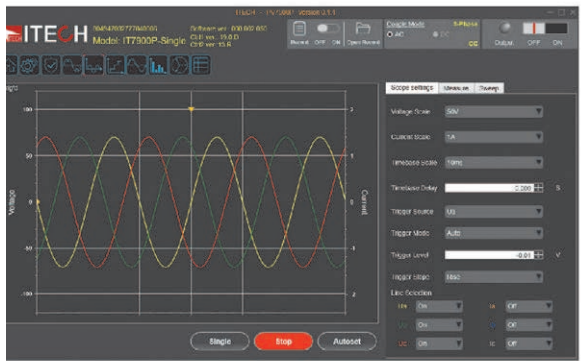

LIST/SWEEP/Surge & Sag modes

IT7900P series supports NORMAL, LIST and SWEEP mode. Each mode can work with Surge&Sag function.

- In LIST mode, a single file supports up to 200 steps, and the waveform type, voltage, frequency, slope and start-stop phase angle can be selected under each step. When the output voltage or frequency jumps, a trigger signal can be generated to synchronize external devices, which is especially suitable for large-scale test platforms with strict logic control and fast response for inter-device linkage.
- SWEEP is suitable for AC mode, which can test the efficiency of switching power supply, grab the voltage and frequency of the maximum power point, and change the setting parameters in a step-by-step way.
- In NORMAL/LIST/SWEEP modes, Surge&Sag can work with each of them. The surge and sag can be controlled by trigger or cycle, and the starting angle of the drop can be set, and waveform smoothing, symmetrical and asymmetrical waveform operations are supported. Waveforms can be quickly created to replicate waveform distortions or transient status such as spikes, dropouts, or any other anomalies that can be seen as a single cycle.

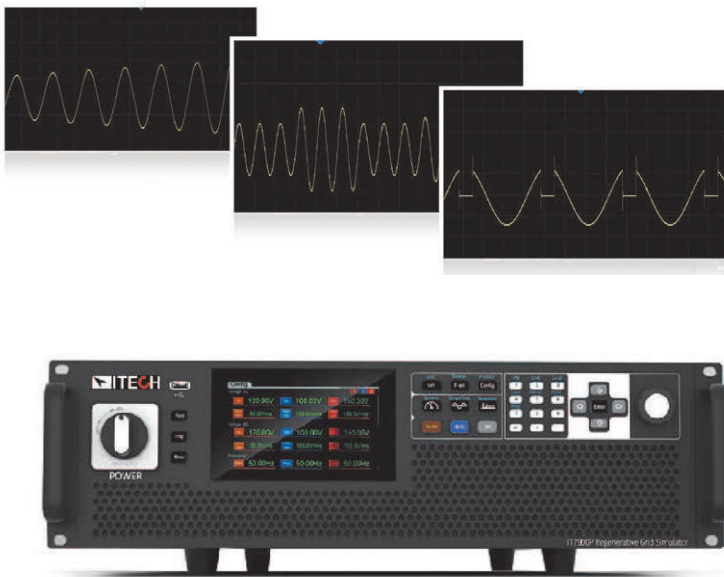

Harmonic analysis

Harmonic analysis functions include both voltage and current harmonic measurement. In the harmonic mode, the voltage and current total harmonic distortion (THD) and the phase difference test of the harmonic to the fundamental wave can be realized. In addition, you can make multiple harmonic measurements. The test results are displayed in a list, histogram or vector diagram, easy to check.

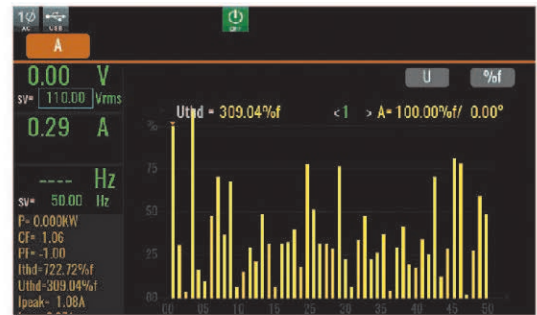

This screenshot shows a table of harmonic data. The table has columns for Harmonic Order (N), Voltage, Angle, THD %, Voltage, Angle, THD %, Voltage, Angle, THD %.

N	Voltage	Angle	Thd %	Voltage	Angle	Thd %	Voltage	Angle	Thd %
0	0.0	0.0	0.0	0.0	0.0	0.0	0.0	0.0	0.0
1	230.0	0.0	100	230.0	0.0	100	230.0	0.0	100
2	0.0	0.0	0.0	0.0	0.0	0.0	0.0	0.0	0.0
3	20.5	90.0	8.9	20.5	90.0	8.9	20.5	90.0	8.9
4	0.0	0.0	0.0	0.0	0.0	0.0	0.0	0.0	0.0
5	0.0	0.0	0.0	0.0	0.0	0.0	0.0	0.0	0.0
6	0.0	0.0	0.0	0.0	0.0	0.0	0.0	0.0	0.0
7	0.0	0.0	0.0	0.0	0.0	0.0	0.0	0.0	0.0
8	0.0	0.0	0.0	0.0	0.0	0.0	0.0	0.0	0.0
9	0.0	0.0	0.0	0.0	0.0	0.0	0.0	0.0	0.0
10	0.0	0.0	0.0	0.0	0.0	0.0	0.0	0.0	0.0

Summary parameters:

- 230.05V (Voltage)
- SV=230.00 Vrms
- 2.33 A (Current)
- SV=50.000 Hz
- P= 470.05 W
- PF= 0.985
- CF= 3.20
- Ipp= 12.075 A
- Vpp= 240.50 V





User-defined waveform function

IT7900P series provides user-defined waveform editing function that allows users to simulate the effects of real AC or DC power supply systems on DUT's in different test environments by importing real waveform data into the device, it supports up to 1024 points of data import.

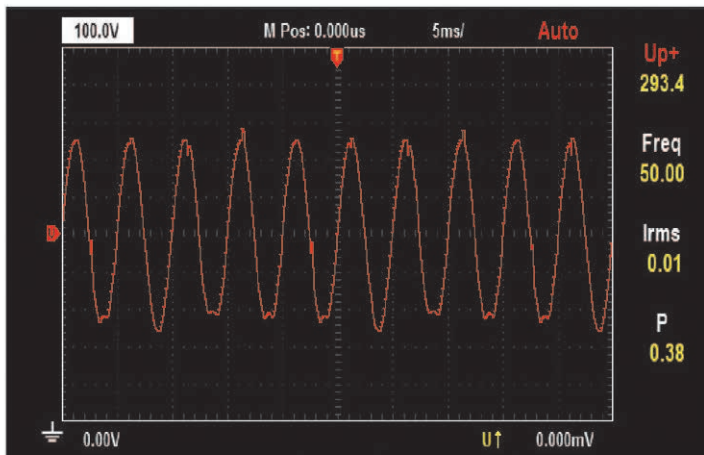
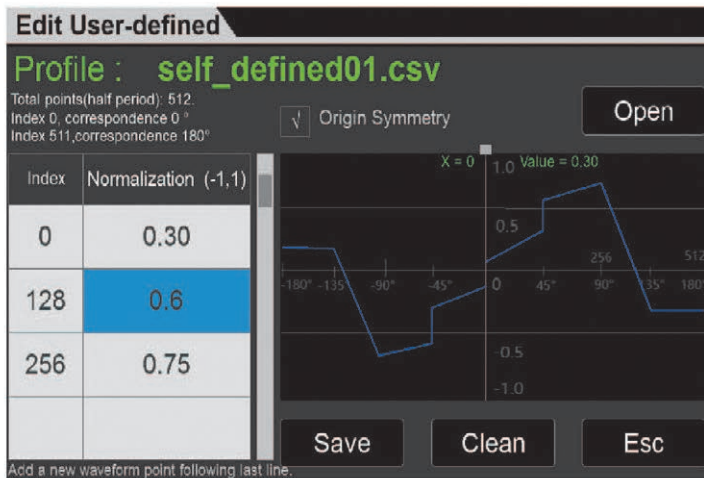

Harmonic and inter-harmonic simulation

With high-speed DSP technology, IT7900P series is capable of simulating harmonic, inter-harmonic and harmonic synthesis. By setting the amplitude and phase, it can simulate up to 50th harmonics(fundamental frequency is 50Hz or 60Hz), creating a periodic distortion waveform. It also has built-in 30 types harmonic distortion waveforms for quick recall. Harmonic test is one of the important tests for EMC immunity, and single-phase harmonics, three-phase harmonics and three-phase harmonic unbalance output can be realized,also meet IEC regulations test requirements.

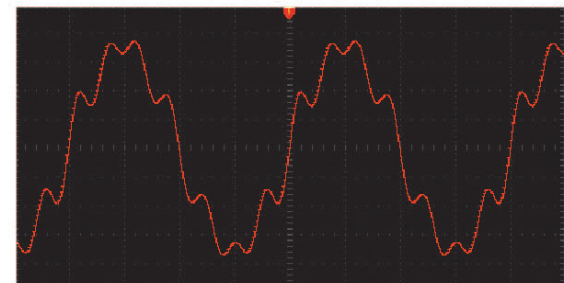
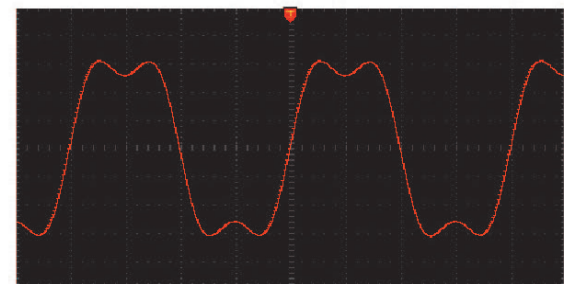
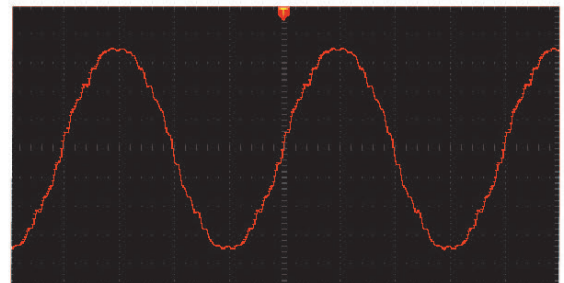
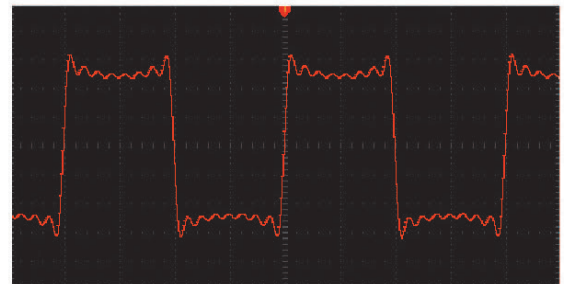

Simulate power grid and low voltage ride through (LVRT) testing

Low voltage ride-through refers to the ability of the power generation system to continue to operate without disconnecting from the grid within a certain range of voltage drop when the grid fault or disturbance causes a voltage drop, and even provides a reactive power to help the system recover the voltage. You can edit the test parameters under LVRT condition. With the fast response, it can fully meet the test requirements of LVRT.

At the same time, the IT7900P series has the function of arbitrary waveform. With the LIST function, it can edit and simulate various grid disturbance waveforms through the panel or software, such as instantaneous power failure, surge and voltage rise and fall.

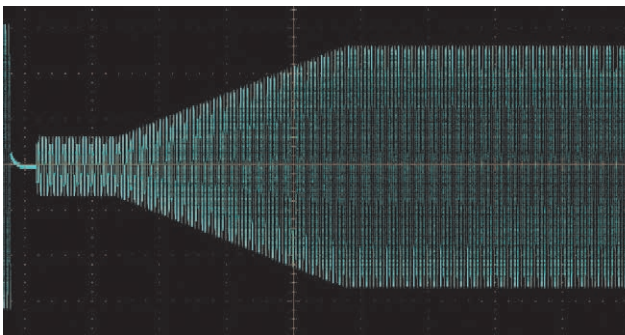

LVRT

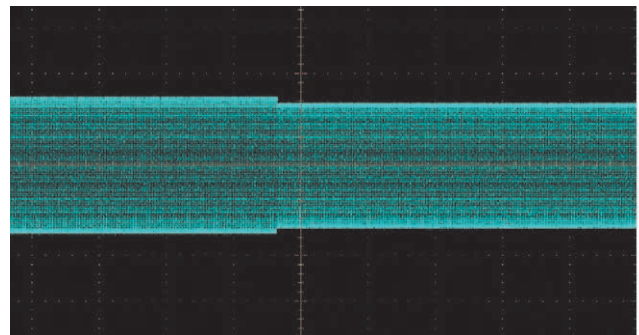

HVRT

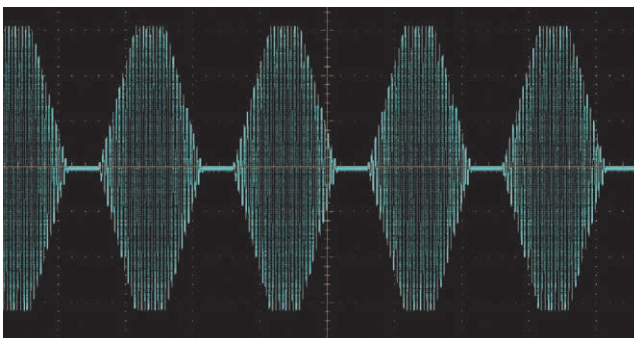

slow rise and fall

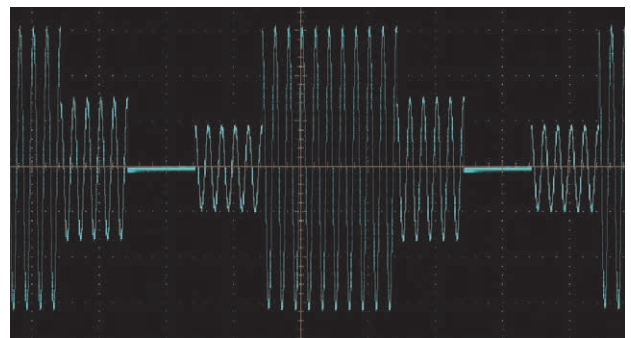

instantaneous power failure

Data acquisition and simulation

IT7900P series integrates an advanced data acquisition system based on digital signal processor, and provides measurement and waveform analysis functions of a digital oscilloscope, a power meter and a digital multimeter. Its current measurement accuracy is as high as 0.1%+0.2%FS, and the voltage measurement accuracy is as high as 0.1%+0.1%FS. 6 oscilloscope curves can be displayed at the same time, which not only saves the cost, but also saves the time for wiring connection. The trigger configuration of IT7900P can synchronously capture the voltage waveform of the DUT, and realize the functions of data acquisition and simulation. The user can import the collected abnormal voltage data of the power grid into the IT7900P to reproduce the power grid status, set the repetition times, offset and other parameters of the waveform.

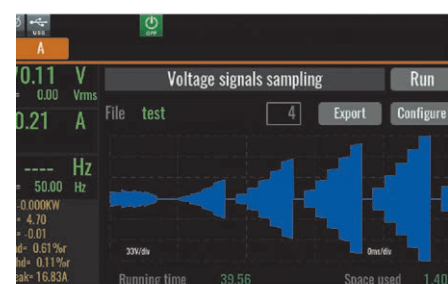
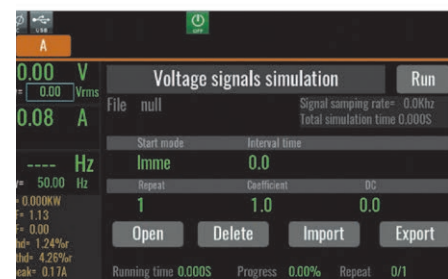

IT7900 Regenerative Grid Simulator



Applications

Electric transportation, New Energy Vehicles, Energy Storage, Research Institute, Power Electronics

Feature

- Adopt advanced SiC technology
- High power density/minimum rack space, 3U up to 15kVA, 16Hz~150Hz
- Regenerative grid simulator & full 4-Quadrant AC&DC power sources
- Power Amplifier function for PHI_L applications
- Professional anti-islanding test mode, can set and simulate the RLC (resistive-inductive-capacitive), active and reactive power circuit for anti-islanding detection *3
- Three working modes: CV/Current Limit/Power Limit
- AC, DC, AC+DC or DC+AC output capability
- Comprehensive working modes selectable: single-phase, three-phase, reversed phase and multi-channel *1
- Programmable Output Impedance, allows simulation of Real-World Utility Grid Impedance.
- Compliance tests incl. LVRT /Phase Jump/Frequency variation /Harmonic Injection
- Supported regulatory testing include IEC61000-4-11/4-13/4-14 /4-28 etc.
- Wide voltage ranges: 350V L-N
- Master-slave parallel with current sharing technology, up to 960kVA
- Harmonics and Interharmonics waveform synthesizer
- Power line disturbance simulation testing by List programming/Sweep/ Surge&Sag functions
- The harmonic measurement function can measure 50th order harmonics of voltage and current. *2
- Output 0-360 ° start/stop phase angle can be set
- Front panel USB port for data and waveform import and export
- Provide rich trigger configuration, synchronously capture the voltage waveform of DUT, collect and simulate data
- Relay CTRL function, to cut off the connection between instrument and DUT
- 6-phase, 12-phase power output
- Built-in USB/CAN/LAN/Digital IO interface, optional GPIB /Analog&RS232

*1 <6kVA model only support single phase *2 Voltage and current harmonic analysis, Voltage harmonic simulation *3 Not available for multi-channel mode

The IT7900 series is a programmable, four-quadrant grid simulator. It is also a four-quadrant power amplifier, which can be used to test various grid-connected equipment. For example, PCS, energy storage system, microgrid, BOBC (V2X), PHI_L, etc. With advanced SiC technology, a single unit of IT7900 can realize the anti-islanding protection test through islanding mode (RLC settable). Besides, the power density of IT7900 series is very high, 15kVA in 3U. After parallel connection, the power can be extended to 960kVA at most.

Model	Voltage	Current	Power
IT7905-350-30U	350 V L-N	30 A	5kVA
IT7906-350-90	350 V L-N	90 A	6kVA
IT7909-350-90	350 V L-N	90 A	9kVA
IT7912-350-90	350 V L-N	90 A	12kVA
IT7915-350-90	350 V L-N	90 A	15kVA
IT7930-350-180	350 V L-N	180 A	30kVA
IT7945-350-270	350 V L-N	270 A	45kVA
IT7960-350-360	350 V L-N	360 A	60kVA
IT7975-350-450	350 V L-N	450 A	75kVA
IT7990-350-540	350 V L-N	540 A	90kVA
IT79105-350-630	350 V L-N	630 A	105kVA
IT79120-350-720	350 V L-N	720 A	120kVA
IT79135-350-810	350 V L-N	810 A	135kVA
T79150-350-900	350 V L-N	900 A	150kVA
IT79165-350-990	350 V L-N	990 A	165kVA

* Reverse phase and phase-locking functions help to meet higher voltage testing requirements

*For more high power, please call for availability

Outstanding Features

Regenerative 4-Quadrant AC Grid Simulator

The IT7900 series are four-quadrant grid simulators with 100% of power sinking and 88% energy recovery capability. The power generated by the DUT can be fed back to the grid, rather than being dissipated as heat, which protects the environment and save the cost of electricity, HVAC and cooling infrastructure.

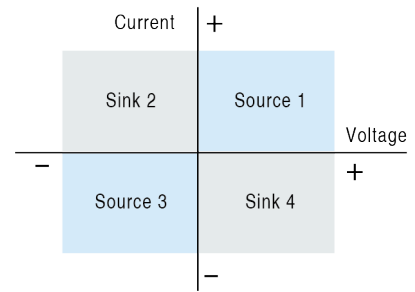

Production: 24Hr/day x 365 day

R&D: 8Hr/day x 5 workday x 52 weeks

Power (kW)	Electricity saved (kWh)	Cost Saved*1*2 (USD)
15	115,632	115,632
90	693,792	693,792
165	1,271,952	1,271,952
960	7,400,448	7,400,448

Power (kW)	Electricity saved (kWh)	Cost Saved*1*2 (USD)
15	27,456	3,844
90	164,736	23,063
165	302,016	42,282
960	1,757,184	246,006

*1 Note: approximate electricity price 0.14USD/ kWh for industry facility in California

*2 The extra cost of air conditioning is not included.

Full 4-Quadrant Power Amplifier

The IT7900 series regenerative grid simulator can be used as a power amplifier to complete power hardware in the loop (PHIL) applications for microgrids, energy storage and new energy vehicles. The digital I/O or a standard suite of analog signal can be input via an external analog interface (optional) and then amplified without distortion to a real power waveshape with an external analog response time of less than 200us.

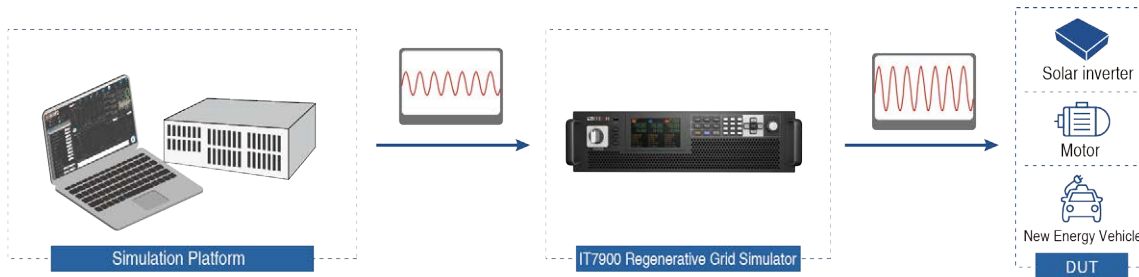

Professional Anti-islanding Test Mode

Anti-islanding protection is one of the must-test items for grid-connected inverters. IT7900 series has built-in anti-islanding protection test function, which allows testers to set the active power of resistor R, the reactive power of inductor Q and capacitor C, and also set resistor R, inductor Q, and capacitor C to simulate the inter-network resonance and test the anti-island protection function of grid-connected inverter. IT7900 island test mode can simplify the test process, improve test efficiency, and complete the test of the anti-islanding protection function in the process of grid-connected inverter research and development test, factory inspection, etc.

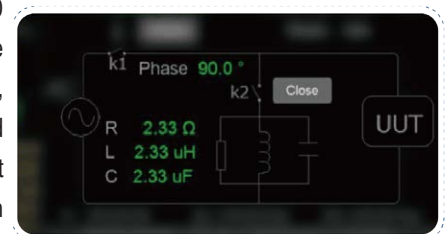

Outstanding Features

Constant voltage/Current limit/Power limit

In order to meet the increasingly complex test requirements, the IT7900 regenerative grid simulator has included current limiting and power limiting modes besides the CV mode. Its output parameters (Vset/I limit/P limit) can be adjusted. When the loading current of the DUT exceeds the set current limit value, it will switch to the current limit mode and output at the current limit value while reducing the output voltage. The working principle under limited power mode is similar. Current limit and power limit mode are well applied to test of motors with high inrush current at the moment of starting or capacitive load testing.

Application

DUT: Inductive or capacitive products

Advantages: Traditional AC sources can only provide current RMS and current peak protection functions. When the starting inrush current of the DUT exceeds the rated current of the AC source, the overcurrent protection will be triggered immediately, leading to the failure of start. In this case, you have to choose a test instrument with a higher rated current to achieve the purpose of the experiment. The current limiting mode of IT7900 can solve this problem well. In the start-up phase of the DUT, the inrush current is limited and output at the maximum current limit until the DUT enters the normal working current state.

Application: Microgrid Testing

Microgrids can be seen as small power systems, but they are also a typical distributed generation system, so both equipment manufacturers and professional grid research laboratories need to establish simulation testing requirements. The IT7900 series not only meets the testing requirements of phase angle jump, low voltage ride-through, frequency variation and harmonic injection, but also feeds power back to the AC grid, meeting the microgrid testing requirements.

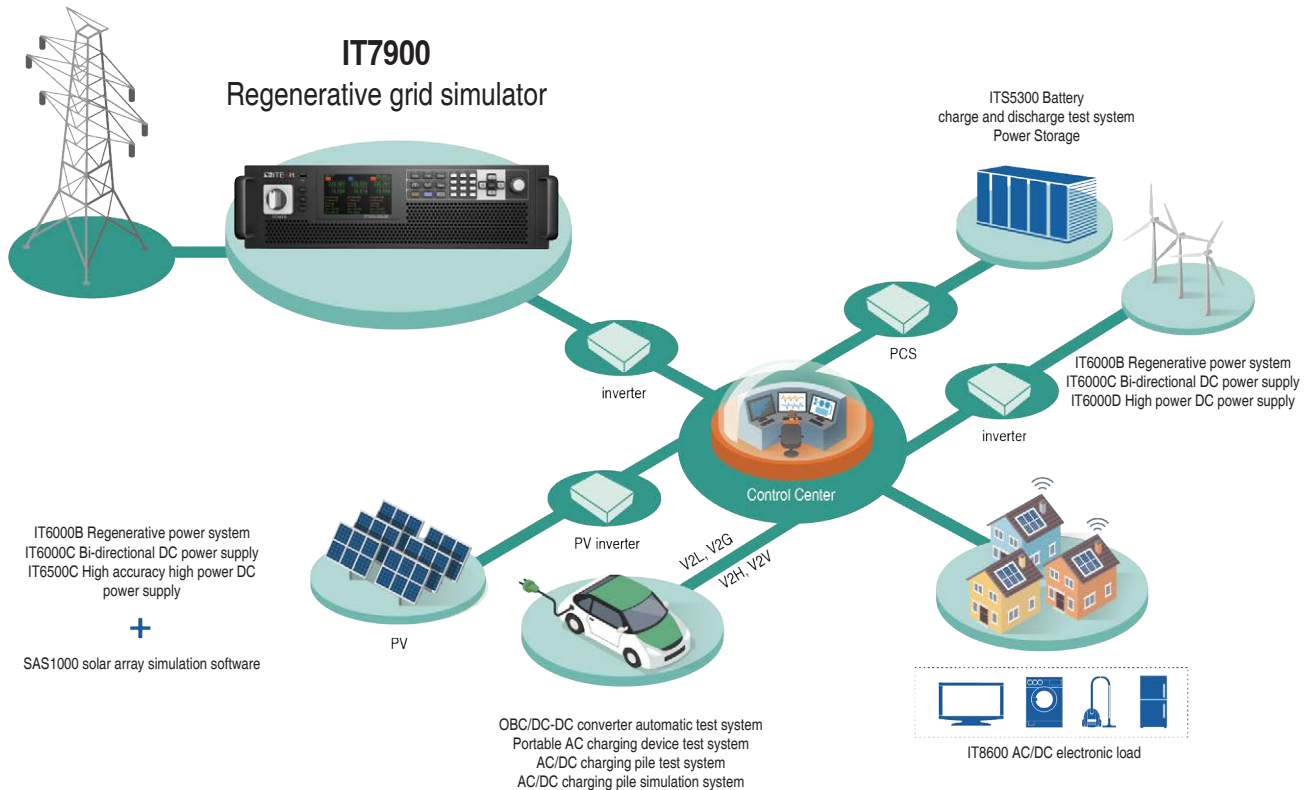

High-power Density, Modular Design

15kVA/3U High-power Density

With PWM switching technology, the power density is up to 15kVA in a compact 3U size. The voltage is 350V-L-N and the frequency range is 16Hz~150Hz. The size is only 1/12 of a conventional type of AC power supply, and the power could be expanded higher, saving a lot in space and cost.

3U
15kVA

350V

ATE
set up

bench
test



IT7900 Regenerative Grid Simulator
15kVA

3U



Traditional power supply
15kVA

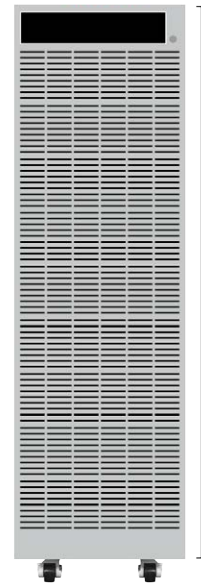

37U

Master/Slave parallel, power up to 960kVA

IT7900 series can be master-slave paralleled to get higher current and power. Maximum 64 sets can be paralleled to reach 960kVA, the parallel is flexible and convenient.

IT7900 comes with synchronous On/Off input and output signals, which ensure the synchronization of paralleling and ensures synchronous current sharing of multiple modules. After paralleling, all functions are retained and there's no loss of accuracy, making the construction of the power system faster, more flexible, and more economical, either it is a stand-alone test or ATE system.



960kVA
High power

Application: UPS testing

·Testing purpose: the input and output testing of UPS, the AC input disturbance testing of UPS and etc.

·Application advantage: UPS modules are normally 10kVA~50kVA, by cascade connection, the UPS system can be MW, and they are used in power system, data center and etc. IT7900 series are very suitable for testing the DUT whose power will be expanded at any time without adding additional testing cost. IT7900 single module unit can test UPS module, when UPS capacity gets higher, IT7900 can still test it after paralleling.

Easy-to-operate interface, abundant operation modes

Easy-to-operate interface, abundant operation modes

IT7900 series is equipped with innovative touch screen, simple and intuitive UI interface, and the keyboard knob design allows users to directly and quickly perform operations such as mode setting and waveform editing. The built-in digital oscilloscope function collects time-domain signals of voltage and current, phase relationship and performs waveform trigger functions. The oscilloscope sampling rate is up to 10us, and up to 6 oscilloscope curves can be displayed at the same time. Users can perform instantaneous analysis without an oscilloscope and save them in time.



* Stay tuned!

AC,DC,AC+DC,DC+AC working mode

IT7900 series can be used as a "full four-quadrant AC/DC power supply" and provides four output modes: AC, DC, AC+DC, and DC+AC. Not only provide pure AC/DC output, use AC+DC and DC+AC output modes to realize "AC output superimposed DC bias" and simulate "DC output waveform with ripple" to meet the complex application requirements of engineers. In DC mode, the rated power in 100% AC mode can be achieved.

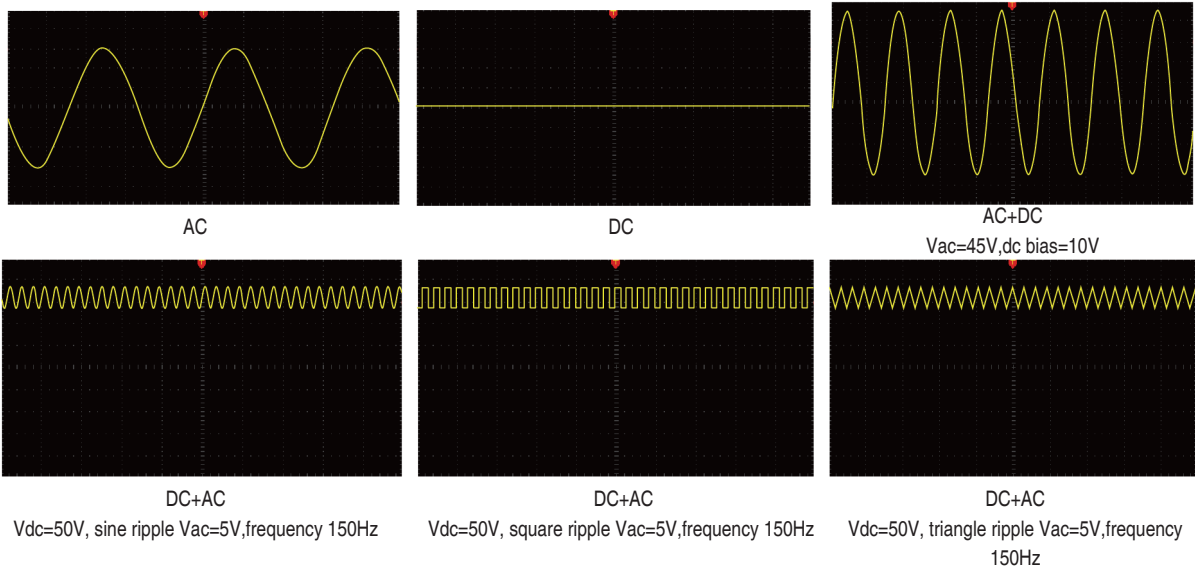

Single-phase, three-phase, reverse phase, multi-channel operation modes

IT7900 series has very flexible operation mode that single-phase, three-phase/ reverse phase /multi-channel output mode can be selected. Combined with the powerful programming function, it can simulate three-phase unbalance , phase loss and phase sequence reverse connection and so on. In the reverse phase mode, users can obtain a single-phase output voltage of up to 700V, and the power remains at 2/3 of the original. Multi-channel mode allows users to test 1-3 independent DUT at the same time. One device for multiple purposes, better equipment utilization, and reduces test costs for enterprises.

IT7900 Operation Mode		
CH1 (1-Phase)	CH2 (1-Phase)	CH3 (1-Phase)
1-Phase		
Reverse Phase		
3-Phase		

Power Line Disturbance (PLD) test

In addition to sine waveform, IT7900 series provides various standard AC waveforms, such as triangular wave, sawtooth wave, square wave, trapezoidal wave and clipped sine wave. These waves can be easily recall from the menu and displayed in the LCD touch screen. Moreover, in combination with sequence programming function, users can realize multiple waveform continuous output, to cope with complex power line disturbance test.

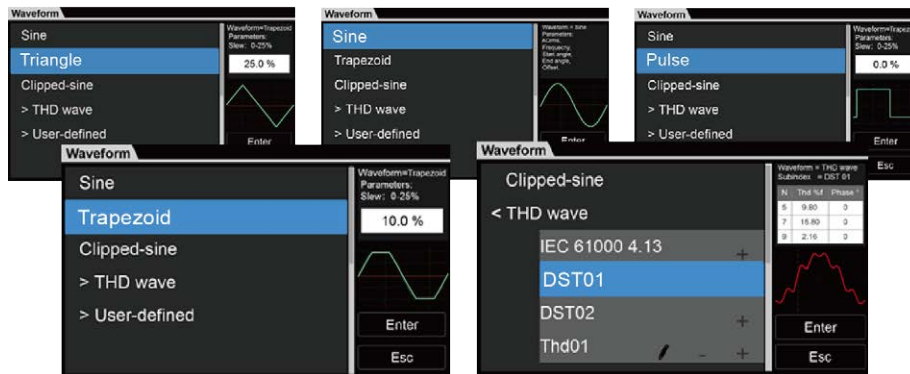

LIST/SWEEP/Surge & Sag modes

The IT7900 series supports LIST/SWEEP/Surge&Sag modes, and through easy parameter configuration can quickly complete a variety of grid disturbance waveform simulation, such as instantaneous power down, surge and voltage slow rise and slow fall, etc. In LIST mode, a single file supports up to 2000 worksteps, and each workstep can select the waveform type, set the voltage, frequency, slope and start/stop phase angle parameters. During runtime, users can load a new LIST file online without stopping the current file or even interrupting the output. And when the output voltage or frequency jumps, the trigger signal can be generated to synchronize external devices, especially suitable for large test platforms with strict logic control and fast response time for inter-device linkage.

Application: Simulate Grid characteristics

Users can edit and simulate various power disturbance conditions through the IT7900 front panel or programmable software.

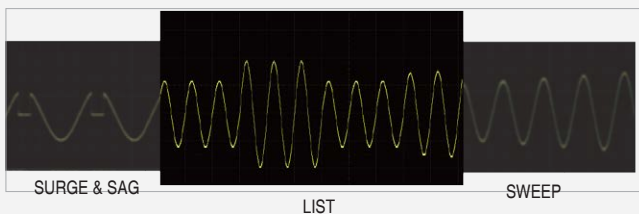

Application: LVRT test

LVRT is the ability of a power generation system, when a grid fault or disturbance causes a voltage dip within a certain voltage dip, it should continue to operate without disconnecting from the grid and even to provide some reactive power to the system to help restore voltage. The IT7900 series allows users to edit low voltage ride-through test conditions using LIST mode, with fast response time to fully meet LVRT testing requirements.

Application: Instantaneous power interruption simulation function

The IT7900 series can also effectively simulate various power interruption scenarios.



Powerful waveform editing function for grid-connected regulations and power electronics disturbance testing

Harmonic and inter-harmonic simulation

With high-speed DSP technology, IT7900 series is capable of simulating harmonic, inter-harmonic and harmonic synthesis. By setting the amplitude and phase, it can simulate up to 50th harmonics(fundamental frequency is 50Hz or 60Hz), creating a periodic distortion waveform. It also has built-in 30 types harmonic distortion waveforms for quick recall. Harmonic test is one of the important tests for EMC immunity, and single-phase harmonics, three-phase harmonics and three-phase harmonic unbalance output can be realized, also meet IEC regulations test requirements.

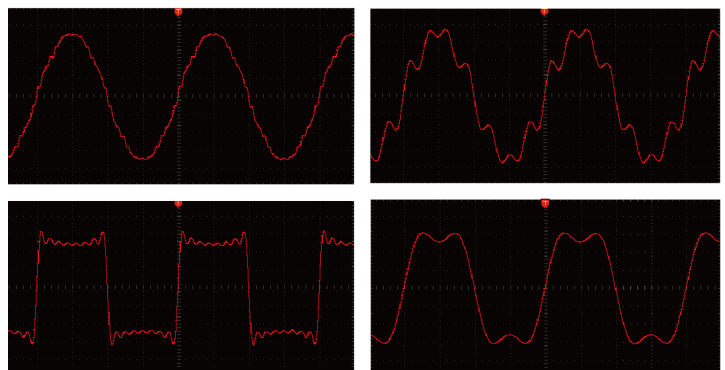
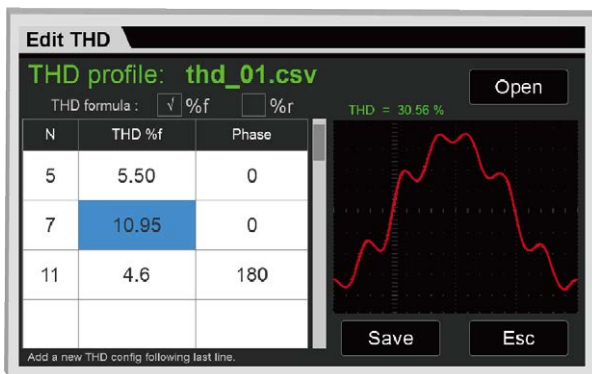

User-defined waveform function

IT7900 series provides user-defined waveform editing function that allows users to simulate the effects of real AC or DC power supply systems on DUT's in different test environments by importing real waveform data into the device, it supports up to 1024 points of data import.

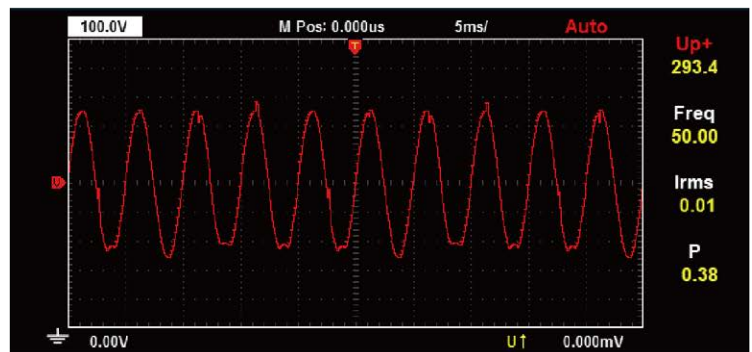
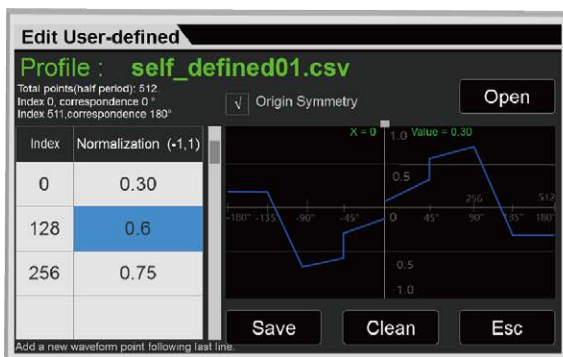

DUT: AC-DC power conversion module

- Reference test standard: IEC61000-4-13
- Testing advantages: For power electronic equipment, the design stage requires the developers to consider the impact of each harmonic in the grid on the power-using equipment. IT7900 series meets the IEC61000-4-13 standard for harmonic and inter-harmonic disturbance simulation requirements, the user can set the number of harmonics, harmonic phase angle, harmonic percentage through the configuration interface, it's easy to operate.

Measurement and waveform collection

Built-in power meter - current accuracy up to 0.1% + 0.2% FS

The IT7900 series integrates a data acquisition system which is based on a advanced digital signal processor. It provides the measurement and waveform analysis capabilities of oscilloscopes, power meters and digital multimeters commonly found in test systems. The current measurement accuracy is up to 0.1%+0.2%FS and voltage measurement accuracy is up to 0.1%+0.1%FS. The parameters that can be measured include voltage RMS, current RMS, frequency, active power and power factor, etc. Up to 6 waveform curves can be displayed simultaneously, saving cost and simplify the operation.



Harmonic analysis and simulation

The harmonic analysis function of IT7900 series includes voltage harmonic measurement and current harmonic measurement. In the harmonic mode, the voltage and current harmonic distortion factor (THD) and the phase difference of the harmonic to the fundamental wave can be tested. In addition, it can measure multiple harmonics, and the results are displayed in tables, bar graphs or vector charts, making it easy to analyze test results at a glance.

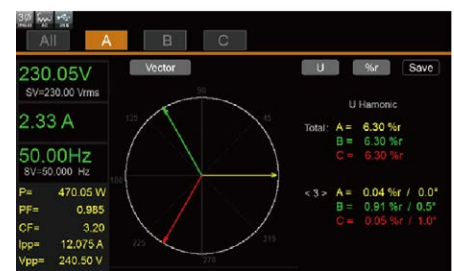
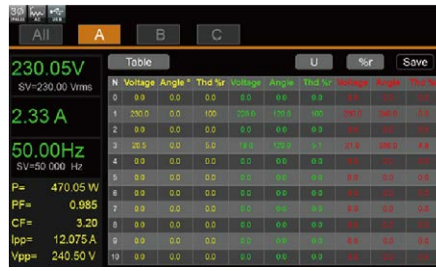
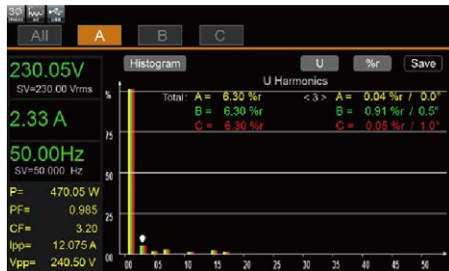

Data record

Thanks to the function of large data recording, IT7900 series is capable of recording up to 7 hours of continuous data at short intervals (fastest: 100ms). And it's easy to view the complete curve generating from the start to the end of the test. There are six curves that can be displayed at the same time at most. In addition, you can slide the vernier calipers on the screen to check the exact data at a particular point in the current trend curves. It is useful for analyzing errors during test for a long time or inflection points during loading, etc. Besides, you can export the test data for further analysis by front panel USB interface.



Programmable output impedance

The function of programmable output impedance allows you to edit the output R and L so as to simulate the impedance of the AC grid in accordance .

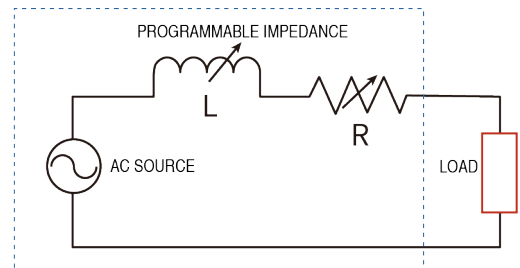

IT7800 High Power AC/DC power supply



Applications

Appliance, Civil aviation, New Energy, Power electronics, Research institute, lab, testing organizations, Medical equipments

Feature

- Adopt advanced SiC technology
- High power density, 3U up to 15kVA
- Master-slave parallel with current sharing technology, up to 960kVA, multiple units in parallel work as one
- Voltage up to 350V L-N
- Output frequency: 16-2400Hz, programmable slew rate setting for changing voltage and frequency
- Built-in single/3-phase AC power meter
- Multi-channel function, single unit can connect/test up to 3 DUTs*2
- 4 output modes: AC/DC/AC+DC/DC+AC
- Choose single phase, three-phase, reverse phase output mode, to simulate 3-phase imbalance, 3-phase harmonics imbalance, 3-phase split phase test, reverse phase sequence tests for 3-phase models and etc.*3
- Comprehensive harmonics measurement and analysis, up to 50th*4
- Harmonics, inter-harmonics waveform synthesizer
- Programmable output impedance
- Intuitive touch screen interface
- Simulate arbitrary waveform output, support csv. file import
- High current crest factor, suitable for inrush current testing*5
- Built-in various waveforms
- List mode simulates the power supply reproduction function to realize the simulation function of instantaneous power interruption
- Provide rich trigger configuration, synchronously capture the voltage waveform of DUT, collect and simulate data.
- Output 0-360 ° start/stop phase angle can be set
- Surge/Sag function
- Relay CTRL function, to cut off the connection between instrument and DUT 6-phase, 12-phase power output
- Built-in USB/CAN/LAN/Digital IO interface, optional GPIB / Analog&RS232
- Build-in IEC standard compliance testing waveforms for IEC 61000-4-11/4-13/4-14/4-28
- Optional software can help complete the pre-compliance standards test of civil avionics/electrical ships interms of the multi-national safety regulations

*1 Call for availability *2 Not available for 3k/5kVA model *3 3k/5kVA model only support single phase

*4 Voltage and current harmonic analysis and voltage harmonic simulation *5 maximum CF is up to 6 within peak currnt range

Adopting advanced SiC technology, ITECH IT7800 3U high series of programmable AC/DC power supply, with power up to 15kVA, voltage ranges up to 350V L-N. Users are able to increase output power up to 960kVA by configuring master-slave parallel. With intuitive LCD touch panel interface, users can be quickly familiar with the unit operation.

IT7800 series is built-in power meter and arbitrary waveform generator, which is able to simulate harmonics and other arbitrary waveform output. Users can choose single phase, three-phase, phase reversal, and multi-channel totally 4 output modes, with programmable output, and complete measurements, ITECH IT7800 series is designed for new energy, power electronics, research institutes etc.

Model	Voltage	Current	Power
IT7803-350-30U*2	350 V L-N	30 A	3kVA
IT7803J-350-30U*1	350 V L-N	30 A	3kVA
IT7805-350-30U*2	350 V L-N	30 A	5kVA
IT7806-350-90	350 V L-N	90 A	6kVA
IT7809-350-90	350 V L-N	90 A	9kVA
IT7812-350-90	350 V L-N	90 A	12kVA
IT7815-350-90	350 V L-N	90 A	15kVA
IT7830-350-180	350 V L-N	180 A	30kVA
IT7845-350-270	350 V L-N	270 A	45kVA
IT7860-350-360	350 V L-N	360 A	60kVA
IT7875-350-450	350 V L-N	450 A	75kVA
IT7890-350-540	350 V L-N	540 A	90kVA
IT78105-350-630	350 V L-N	360 A	105kVA
IT78120-350-720	350 V L-N	720 A	120kVA
IT78135-350-810	350 V L-N	810 A	135kVA
IT78150-350-900	350 V L-N	900 A	150kVA
IT78165-350-990	350 V L-N	990 A	165kVA

*1 Single-phase AC input terminal

*2 Three-phase AC input terminal, support single-phase / three-phase AC input

*Reverse phase and phase-locking functions help to meet higher voltage testing requirements

*For more high power, please call for availability

3U/15kVA high power density

With only 3U size, ITECH IT7800 can reach both 15kVA for power and 350V L-N for voltage. Compared with conventional AC source, it saves a lot of space for users.



IT7800 high power programmable AC/DC power supply

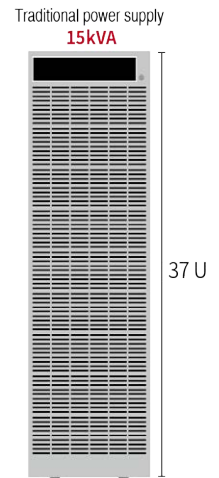

Master/Slave parallel

ITECH IT7800 series can provide more power by using the master/slave parallel output function, with 64 units in paralleled, to achieve total output power max. 960kVA.

IT7800 comes with synchronous On/Off input and output signals, which ensures the synchronization of paralleling and ensures synchronous current sharing of multiple modules. After paralleling, not only all functions are retained, but there is no loss of accuracy. Make the construction of the power system faster, more flexible, and more economical, whether it is a stand-alone test or ATE system, it can be easily reached.



Intuitive touch panel design

The IT7800 series is equipped with a brand-new touch screen design, a simple and intuitive GUI interface, and the keyboard knob design allows users to perform tests directly and quickly. Users can choose different interface display styles, customize the parameter types and display positions of the page, and the user-friendly settings can meet various measurement needs in the test.

The screen can display real-time voltage and current curves, up to 6 waveforms, users can perform instantaneous analysis without an oscilloscope, and save them.



Multi-channel function

The multi-channel function of the IT7800 series allows users to test 3 independent DUT at the same time without adding additional hardware configuration. In the traditional solution, 3 tests for the DUT, the user needs to configure 3 AC power supplies; and one IT7800 device can meet multi-channel testing requirements. For example, IT7815-350-90 rated power is 15kVA, can provide single-phase/three-phase 15kVA DUT test, can also meet up to 3* single-phase DUT test, one machine with multiple functions, fully improves the equipment utilization.

The output frequency can reach 2.4kHz, the voltage or frequency output variation rate is adjustable

The output frequency of IT7800 series is adjustable between 16-2400Hz, allowing users to set the voltage or frequency output variation rate by themselves, so that the voltage or frequency gradually reaches the set value in a regular manner. Therefore, it can verify the operating range of the product more accurately, and can also reduce the surge current when the DUT is turned on.

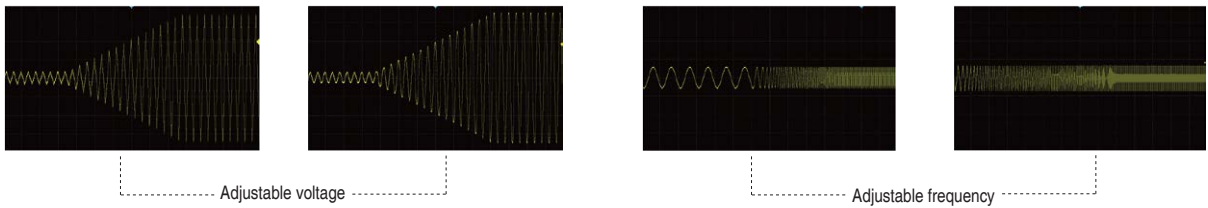

AC、DC、AC+DC、DC+AC

The IT7800 series has four output modes: AC, DC, AC+DC, DC+AC. It not only provides pure AC/DC output, but also can use AC+DC and DC+AC output modes to realize "AC output plus DC bias" And "DC output waveform with ripple", which cover a wider range of applications.

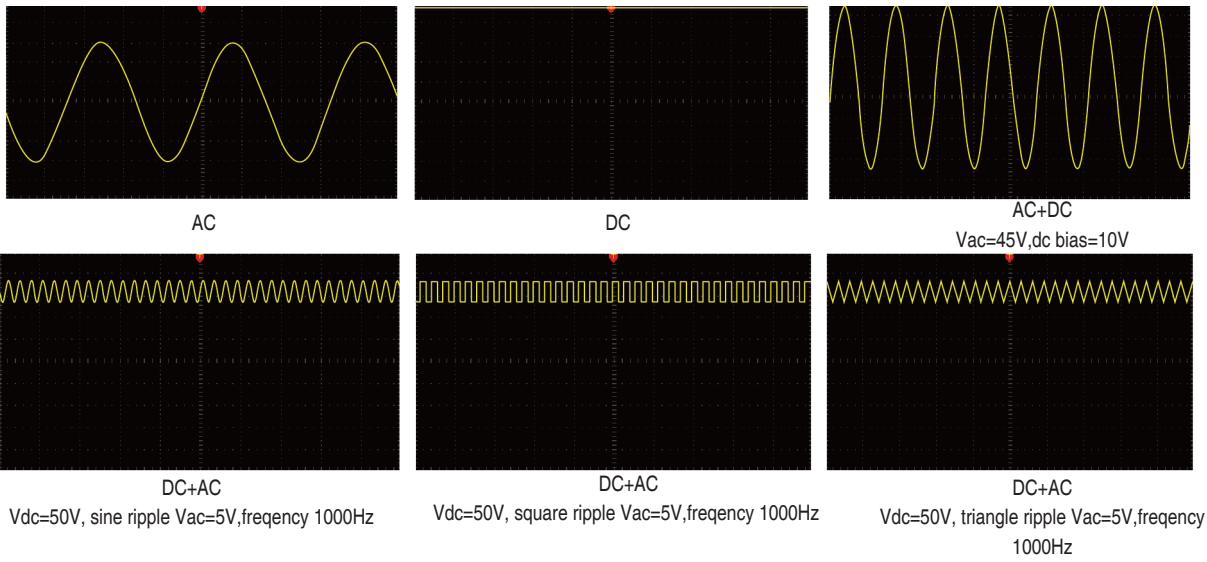

List

Through LIST, SWEEP and Surge&Sag mode, IT7800 series can easily realize the stepwise or continuous change of output parameters. Its output voltage amplitude, frequency, phase, waveform and other parameters can also be output by controlling the internal trigger or external trigger of the instrument. Therefore, it can simulate the characteristics of instantaneous power failure, surge, and slow rise of various power supplies.

No	ACrms V	Freq Hz	Time S	More
1	50.500 / 55.000 / 55.000	50.000	0.2	...
2	80.000 / 80.000 / 85.000	60.000	1	...
3	60.000 / 80.000 / 85.000	100.00	0.5	...
4	80.000 / 80.000 / 85.000	50.00	0.1	...

230.05V 5V=250.00 Vrms
2.33 A
50.00Hz 5V=50.000 Hz
 P= 470.05 W
 PF= 0.985
 CF= 3.20
 Ipp= 12.075 A
 Vpp= 240.50 V

Single phase, three phase, reverse phase

The IT7800 series provides multiple output modes such as single-phase, three-phase and reverse phase, which can be selected by the user through the panel menu. By programming, it can simulate three-phase unbalance, three-phase harmonic unbalance, lack of phase test, phase sequence reverse connection and other tests, which are flexible and cover more applications. At the same time, IT7800's reverse mode can also provide a high-voltage test solution. Its voltage can be increased to twice and the power remains 2/3. For example, if it is set to 350V, the actual output voltage can reach 700V after the reverse mode is selected.

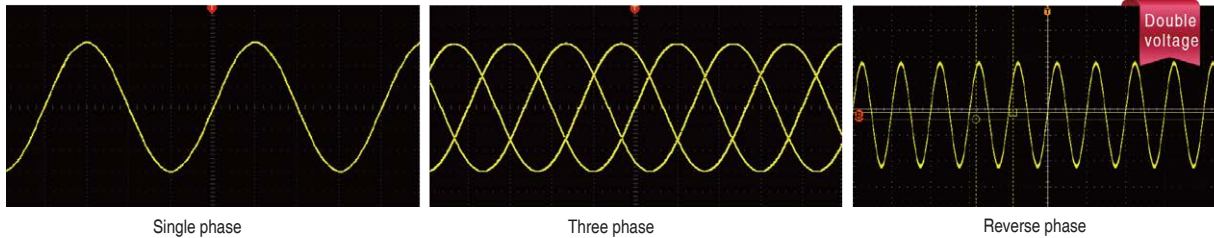

Build-in multiple waveforms

There are many different types of waveforms built in IT7800 series, such as triangle wave, sine wave, square wave, sawtooth wave, etc. Users can recall them through the menu and display the selected waveform on the LCD screen.

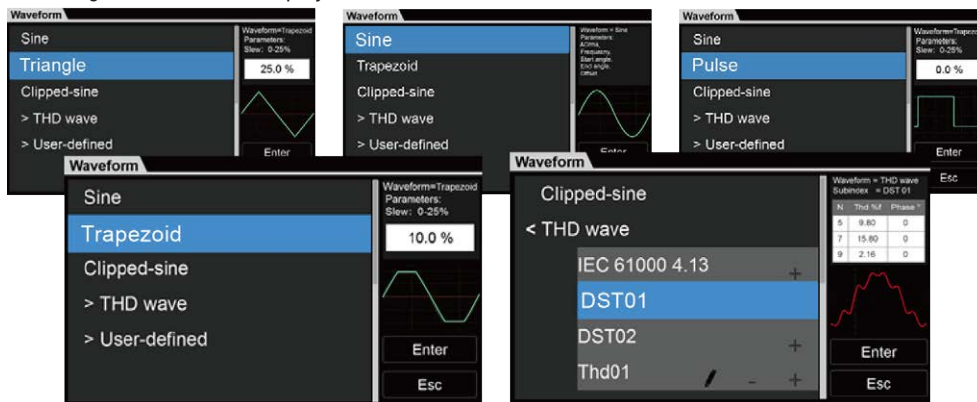

Users can also edit the waveform through the custom mode of the interface to simulate and reproduce the real power waveform at the moment that the problem occurs.

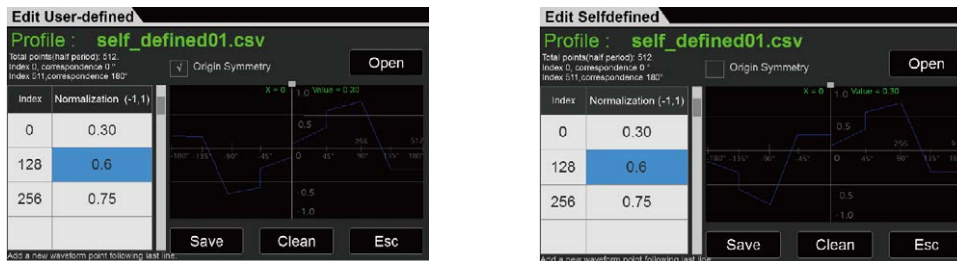

30 built-in harmonic waveforms

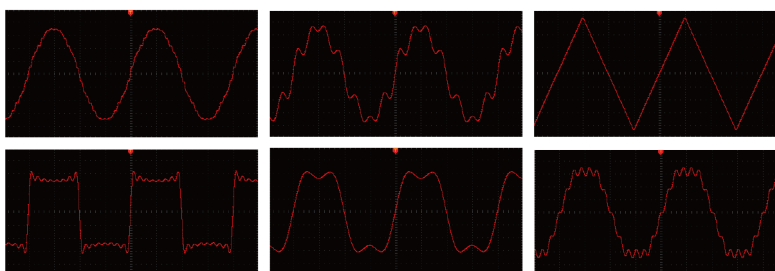

Harmonic analysis and simulation

The harmonic analysis function of IT7800 series includes voltage harmonic measurement and current harmonic measurement. In the harmonic mode, the voltage and current harmonic distortion factor (THD) and the phase difference of the harmonic to the fundamental wave can be tested. In addition, it can measure multiple harmonics, and the results are displayed in a list, histogram or vector diagram, making the test results easy to be seen.

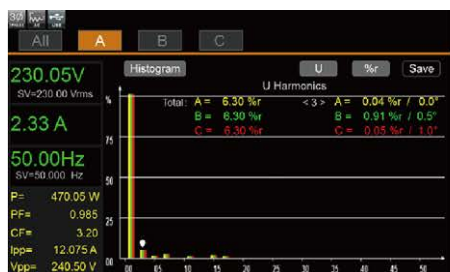

histogram

N	Voltage	Angle	Thd %r	Voltage	Angle	Thd %f	Phase	Angle	Phase
0	0.0	0.0	0.0	0.0	0.0	0.0	0.0	0.0	0.0
1	230.0	0.0	100	230.0	0.0	100	0.0	0.0	0.0
2	0.0	0.0	0.0	0.0	0.0	0.0	0.0	0.0	0.0
3	25.8	0.0	0.0	19.8	0.0	0.0	0.0	0.0	0.0
4	0.0	0.0	0.0	0.0	0.0	0.0	0.0	0.0	0.0
5	0.0	0.0	0.0	0.0	0.0	0.0	0.0	0.0	0.0
6	0.0	0.0	0.0	0.0	0.0	0.0	0.0	0.0	0.0
7	0.0	0.0	0.0	0.0	0.0	0.0	0.0	0.0	0.0
8	0.0	0.0	0.0	0.0	0.0	0.0	0.0	0.0	0.0
9	0.0	0.0	0.0	0.0	0.0	0.0	0.0	0.0	0.0
10	0.0	0.0	0.0	0.0	0.0	0.0	0.0	0.0	0.0
11	0.0	0.0	0.0	0.0	0.0	0.0	0.0	0.0	0.0
12	0.0	0.0	0.0	0.0	0.0	0.0	0.0	0.0	0.0
13	0.0	0.0	0.0	0.0	0.0	0.0	0.0	0.0	0.0
14	0.0	0.0	0.0	0.0	0.0	0.0	0.0	0.0	0.0
15	0.0	0.0	0.0	0.0	0.0	0.0	0.0	0.0	0.0
16	0.0	0.0	0.0	0.0	0.0	0.0	0.0	0.0	0.0
17	0.0	0.0	0.0	0.0	0.0	0.0	0.0	0.0	0.0
18	0.0	0.0	0.0	0.0	0.0	0.0	0.0	0.0	0.0
19	0.0	0.0	0.0	0.0	0.0	0.0	0.0	0.0	0.0

list

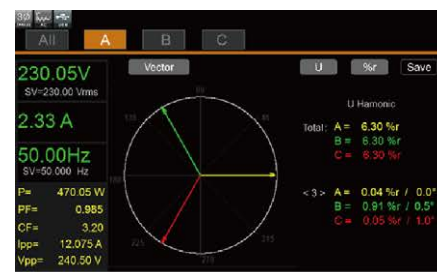

vector diagram

The harmonic simulation function of IT7800 series (single-phase harmonic/three-phase harmonic/three-phase harmonic unbalance) can simulate up to the 50th voltage harmonic.

50th harmonic simulation

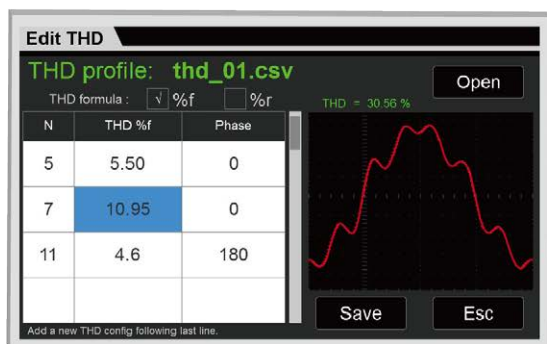

Built-in AC power meter

IT7800 series has built-in single-phase or three-phase AC power meter, which can measure various parameters, including voltage effective value, current effective value, output frequency, active power, power factor, etc. No additional power meter needed, it saves test costs and wiring connection time for users as well.

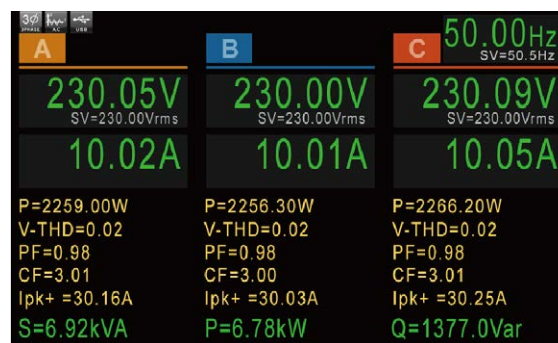

Surge & Sag

The IT7800 series provides a surge/trap simulation function. Users can add a surge/sag to the output sine wave and simulate abnormal voltage fluctuations accordingly, so as to test the performance of the DUT under the situation.



Power Supply

Data record

IT7800 has the function of data recording. Users can observe the trend over a period of time in detail, or observe the data at a certain moment in the current trend graph by sliding the vernier caliper. Up to 6 curves can be observed. The graphic display interface is colorful, allowing users to have an oscilloscope-like experience at the same time.



Sweep

The Sweep function can be used to test the efficiency of the switching power supply and capture the voltage and frequency of the maximum power point. Users can set the start voltage, end voltage, step voltage, start frequency, stop frequency, step frequency and single step time, so that the power supply voltage and frequency can be changed in a step-by-step manner. After the test, the voltage and frequency of the maximum power point can be displayed.

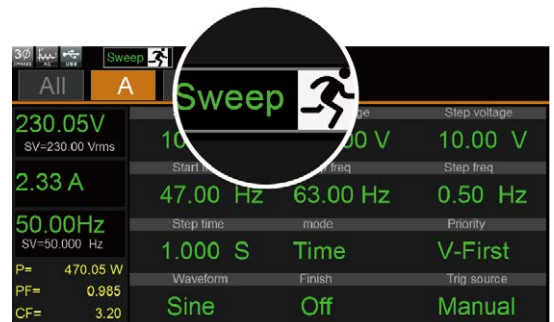

IT-M7700 High Performance Programmable AC Power Supply



Applications

Testing of commercial and commercial avionics, RD, verification and testing of the small-size power supply production, standard testing, Communications/Telecommunications, AC power simulation, Manufacturing and process control, Battery or LCD applications, ATE testing, etc.

Feature

- 1U Half-Rack compact design, increased space utilization
- AC, DC, AC + DC output modes, DC voltage offset simulation in AC + DC mode
- Built-in AC power meter with powerful functions
- Built-in abundant waveform database, including 30 harmonic distortion waveforms
- List mode, simulate civil AC working condition, realize instantaneous power interruption simulation function *1
- Arbitrary waveform output function, user can customize waveforms
- Harmonic analysis function *2
- Harmonic simulation function
- Surge/Trap function
- Front and rear edge Dimmer phase dimming function
- Settable output waveform start/stop phase angle
- Higher voltage available by two units in series connection *2*3
- Three phase output available by three units Y-type external connections *2*3
- Optional interfaces include RS232, CAN, LAN, GPIB, USB_TMC, USB_VCP, external analog, IO. Flexible and cost effective
- With professional software, set up programs comply with multinational security regulations and test conditions, to complete civil aviation electronics related standards testing *3

*1 Realize by PC software

*2 Available on IT-M7721/7722/7722E/7722D/7723D/7723E *3 Coming soon

ITECH newly-launched IT-M7700 High Performance Programmable AC Power Supply combines intelligence and flexibility, breaks through the huge defects of the traditional AC power source, reduces the size to only 1U Half-Rack, maximizes space utilization. Built-in power meter and arbitrary waveform generator make it convenient to simulate various arbitrary waveform outputs. IT-M7700 is designed with advanced technologies of programmable AC and DC power supplies, and can be widely used in multiple fields such as power energy products, home appliances, industrial electronics, commercial avionics and standards testing.

Model	Power(AC/AD)	Voltage	Current	Volume
IT-M7721	300 VA/300 W	300 V	3 A	1U Half-Rack
IT-M7722	600 VA/600 W	300 V	6 A	1U Half-Rack
Coming soon IT-M7722E	1 kVA/1 kW	300 V	10 A	2U Half-Rack
IT-M7723	1.2 kVA/1.2 kW	300 V/600 V	12 A /6 A	1U
IT-M7723E	1.5 kVA/1.5 kW	300 V	15 A	2U Half-Rack

1U Half-Rack Mini size

The conventional AC power supplies are much bigger and heavier, difficult to move. The size of IT-M7700 is only 1U Half-Rack, but its max. power is up to 600VA. Its weight is 4.5kg only. With such high-power density design, the space is better utilized. So it can be portable, convenient for bench testing and good for system building.



Arbitrary waveforms output

Users can self define arbitrary waveforms through IT-M7700 software and download to power supply so as to simulate or duplicate the real waveforms.

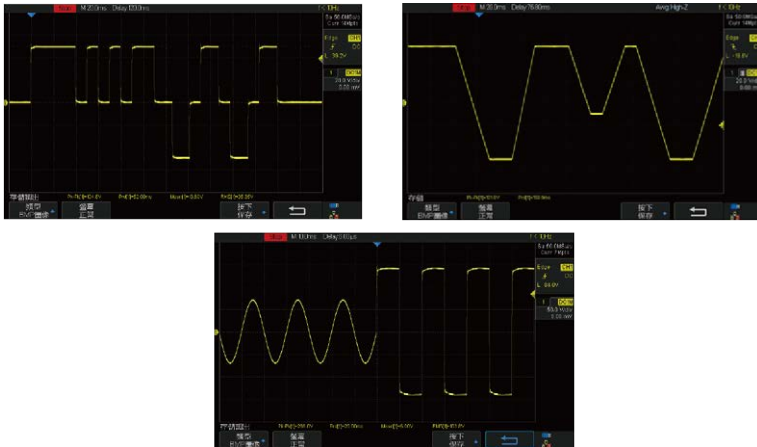

Harmonic analysis function

IT-M7700 series support 40th voltage/current harmonic measurements with the frequency ranging from 45Hz to 50Hz. The analysis results are clearly displayed in list or columnar as showed in following pictures.

ITECH IT-M7700 Series Software - Harmonic Analysis

Order 1	100	Order 11	0	Order 21	0	Order 31	0
Order 2	2.1	Order 12	0	Order 22	0	Order 32	0
Order 3	0	Order 13	0	Order 23	0	Order 33	0
Order 4	0	Order 14	0.1	Order 24	0	Order 34	0
Order 5	0.5	Order 15	0.1	Order 25	0	Order 35	0
Order 6	0	Order 16	0	Order 26	0	Order 36	0
Order 7	15	Order 17	0	Order 27	0	Order 37	0.1
Order 8	2	Order 18	0	Order 28	0	Order 38	0
Order 9	0.1	Order 19	0	Order 29	0	Order 39	0
Order 10	0.1	Order 20	0	Order 30	0	Order 40	0

List

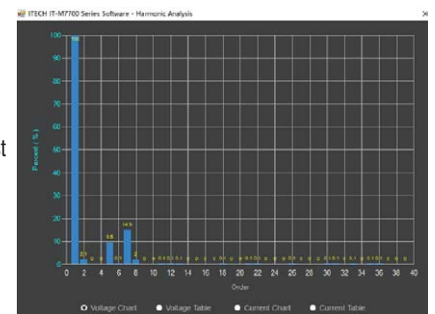

List Mode

IT-M7700 LIST mode supports program complex waveform editing. The users can edit 5 list files, each file can be edited up to 50 steps. Each step settable parameters include: basic waveform (incl. THD and user defined waveform), AC/DC amplitude, slew rate, frequency, dwell time, start/stop phase angle, times of repetition etc. This function with complex waveforms can help users to simulate grid disturbance, periodic power off and so on.

* Available with ITECH PC software.

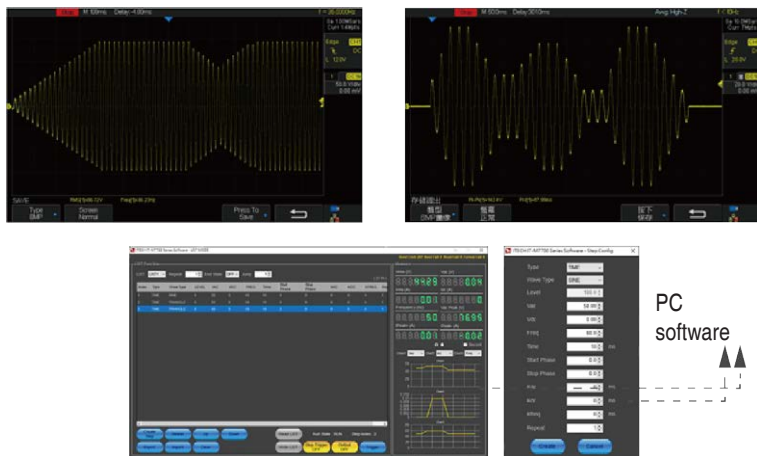

Multiple output modes: AC, DC, AC+DC

The output modes of IT-M7700 series include AC, DC, AC+DC. It can not only provide pure AC or DC output but also AC+DC output mode which can expand application fields and test DC offset element.

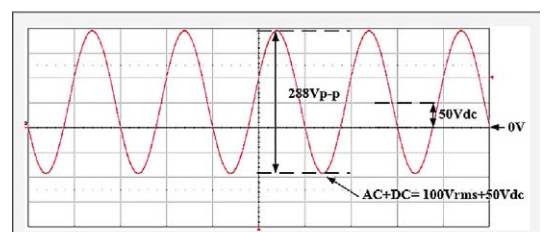
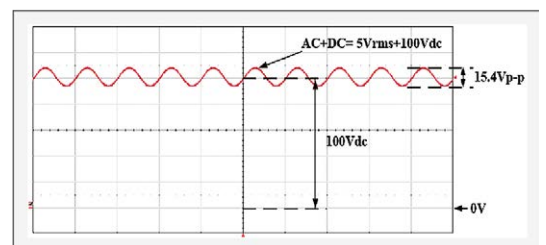



Surge / Trap Wave Function

IT-M7700 series provide surge and trap wave simulation function. User can add surge/trap wave to the output sine wave accordingly, to simulate voltage frequent fluctuation. Thus to simulate the real testing environment.

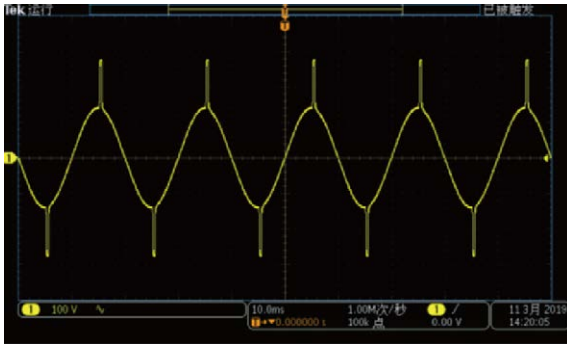

Surge



Trap

Built-in abundant waveform database

IT-M7700 series has a variety of user-defined waveforms such as square, saw and triangle. There are 30 built-in distortion waveforms for users to edit and recall, which can also be used as the basic waveform to be recalled during list programming.

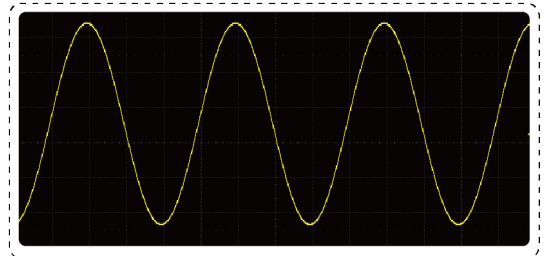

sine

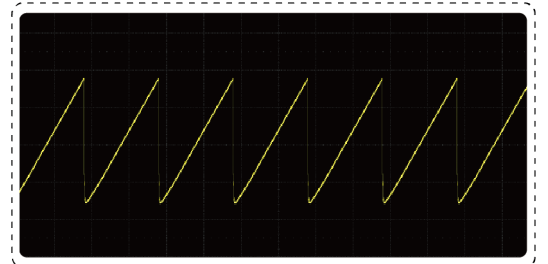

Saw

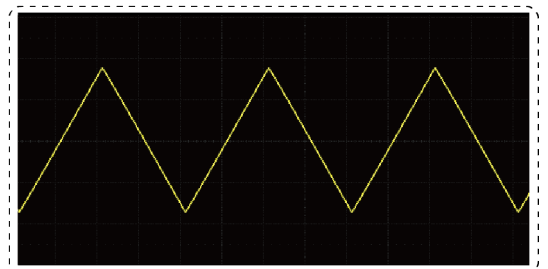

Triangle

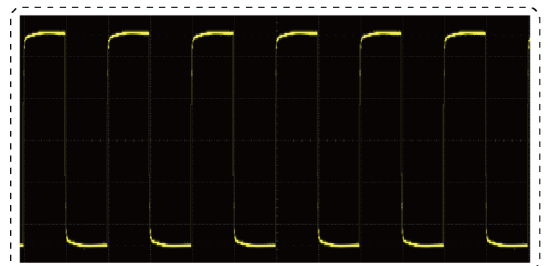

Square

Harmonic simulation function

Within the frequency range 45~50Hz, it can measure up to 50 times, which perfectly simulate the distorted waveform and help to find fast solution.

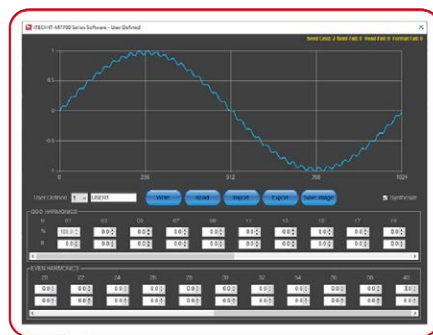

Loading 50 order harmonic components



IT-M7700 series has 30 built-in harmonic distortion waveforms

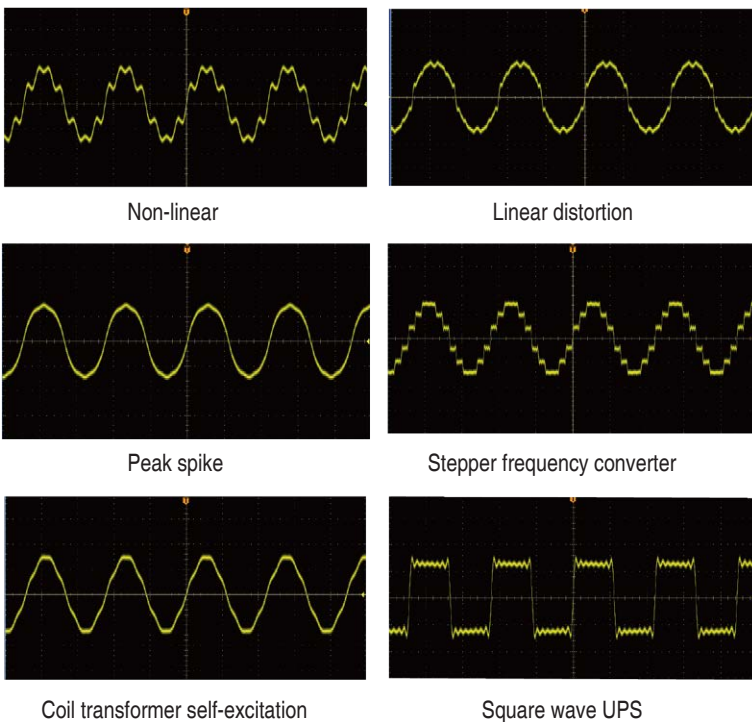

Output waveform start/stop phase angle is settable

IT-M7700 series supports the initial phase and stop phase of the output waveform settable to meet different test requirements. The initial phase and stop phase are set in the range of 0-360°. By adjusting the phase angle, the user can test the rush current of the product at different positions which is widely applied to various switch current impulse tests and various rectifiers test.



Application:

LED driver, household appliances and other products input surge current and power supply disturbance performance verification



IT-M7700 programmable AC power supply

AC input



DC output



IT8912E programmable DC e-load

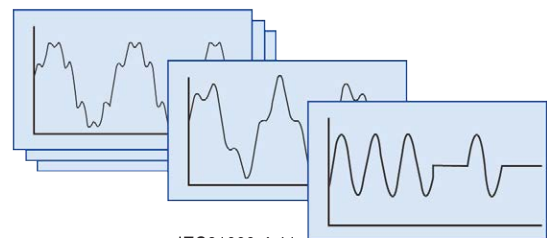

IEC61000-4-11
IEC61000-4-13

Front and rear Dimmer phase dimming function

The IT-M7700 series supports front and rear phase angle dimming or speed control tests. The user can adjust the active power by setting the phase angle and performing the leading or trailing edge waveform concealment to achieve the purpose of adjusting the light intensity of the lamp. It is used to verify whether there is a quality hazard when the end user uses the dimming or speed controller.

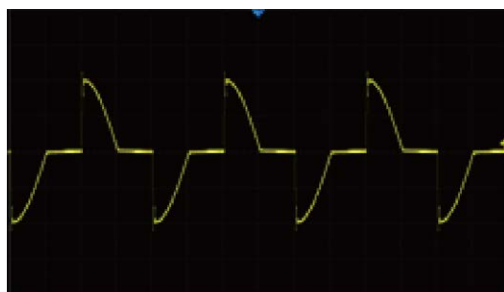

LeadingEdge phase dimming

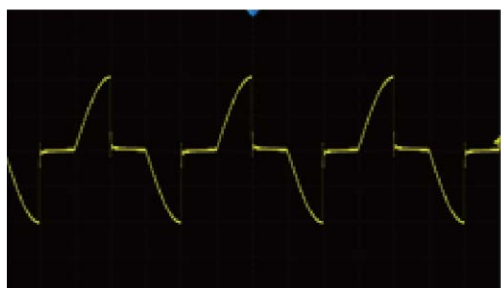

TrailingEdge phase dimming



coming soon

Built-in AC power meter

IT-M7700 provides built-in AC power meter which can accurately measure and display 12 parameters on the screen, including rms voltage, rms current, output frequency, active power, power factor, etc. No need for additional power meter. So it can not only reduce test cost but also get rid of the complex connection operation.

Comprehensive protection

IT-M7700 series provides comprehensive protection, including OVP rms, OVP peak, UVP rms, OCP rms, OCP peak, OCP delay, OPP, OTP and smart fan dysfunctional protection.

Panel operation and remote control

The users can operate easily on the IT-M7700 front panel; IT-M7700 also comes with optional USB, GPIB, LAN and RS-232 interfaces, and an analog interface is also available to support remote control and ATE system quick integration. Supporting LXI and SCPI protocol, the user can remotely control the unit via web-server for convenient control and monitoring.



Rear panel with optional interface IT-E1208

Pictures	Model	Interface
	IT-E1205(optional)	GPIB
	IT-E1206(optional)	USB/LAN
	IT-E1207(optional)	RS-232/CAN
	IT-E1208(optional)	Analog
	IT-E1209(optional)	USB
	IT-E251(standard)	Connection Cable

*For three phase installation and serial connection, pls. choose the optional accessory IT-E251.

3 phase output

Three units single-phase AC power supply can be combined into one unit three-phase AC power supply. Connect 3 units IT-M7721/IT-M7722/IT-M7722D/IT-M7723D/IT-M7723E of the same model through the System Bus to realize the output of three-phase AC power.

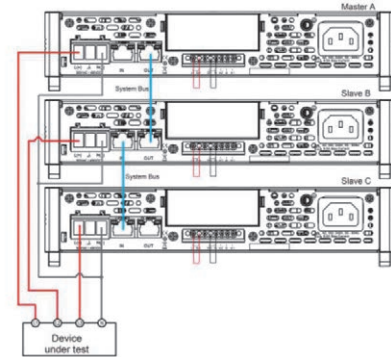

Power Supply

Compliance Test of Commercial Aviation and Ship Electronic Equipment

coming soon

With the strong programming ability, the IT-M7700 series AC power supply can be used to test the immunity of aircraft electrical equipment against AC input changes. With professional software, users can carry out RTCA DO-160D, MIL-STD-704F, ABD0100, Boeing 787B3-0147 and MIL-STD-1399-300B standards test quickly and conveniently. It fully covers the compliance testing of commercial, Commercial aviation, ship and submarine electronic equipment.

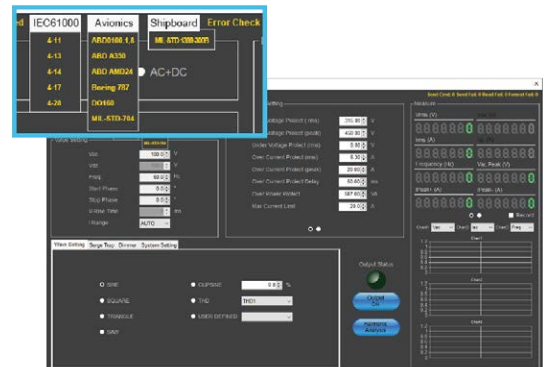

IT7600 High Power Programmable AC power supply



Applications

Testing organizations、 Power electronics、
Home appliances、 New energy、 Scientific
research & Institutions

Feature

- 7" DSO function, which can display real-time waveforms of voltage and current under the single unit or parallel mode
- Built-in AC power meter
- Output frequency up to 10-5000 Hz, output variable rate of voltage or frequency is adjustable
- Maximum power up to 4.5kVA
- Voltage up to 300 V
- Realize AC, DC, AC+DC output modes, AC+DC can realize simulating distortion of DC Voltage
- Simulate arbitrary waveform output, support CSV format to import waveform
- Built-in various waveform database
- Strong master-slave paralleling makes multi-module output equalized current synchronously
- Three single units can complete the three-phase output, and can simulate three-phase unbalanced output
- Strong harmonic simulation capability, up to 50th harmonic simulation*1
- Strong harmonic analysis function, which can measure up to 50th voltage and current harmonic.*1
- List mode can simulate civil use AC network, achieve simulation of instantaneous power interruption
- The output waveform start / stop phase angle can be set
- Support remote sense compensation function, which can improve measurement accuracy
- Relay Ctrl output function, which can achieve electrical isolation between DUT and the source
- Sweep function, which can test the efficiency of switching power supply and catch the voltage and frequency when reaching maximum power point
- OTP, OCP (Including peak and rms values), OPP
- Built-in USB / RS232 / LAN / CAN*2 communication Interface*
- USB on the front panel can achieve importing and exporting file functions and data storage function

*1 10 Hz-500 Hz

*2 Coming soon

*For any GPIB interface option request ,check with ITECH for availability.

Model	Voltage(V)	Current(A)	Power(VA)	Phase
IT7622	150/300	6	750	1φ
IT7624	150/300	12	1.5k	1φ
IT7625	150/300	36	4.5	1φ or 3φ
IT7626	150/300	24	3k	1φ

* IT7627/28/28L/30/32/34/36 has been discontinued, please choose IT7800 series for replacement

7" DSO function

Display real-time waveforms of voltage and current under the stand-alone or parallel mode

IT7600 series high-power AC / DC power supply provide a powerful oscilloscope function by the 7" large screen. Built-in high-speed sampling measurement design realizes the display of real-time voltage and current curves. When multi-units are paralleled, IT7600 can display the status of all paralleled units, instantaneous analysis is available without an oscilloscope.

Simulate arbitrary waveform output

AC voltage and DC voltage deviation simulation

IT7600 series high power AC / DC power supply provide AC voltage and DC voltage deviation simulation functions, and can simulate arbitrary waveform output.

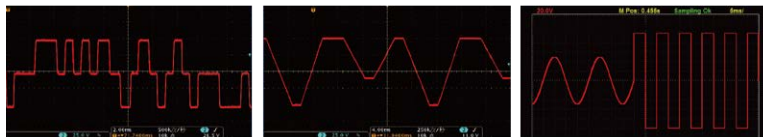

Application: IEC 61000-4-11 test

IT7600 series also can simulate IEC 61000-4-11 to do test for voltage transient drop, short circuit interruptions and voltage variations items.

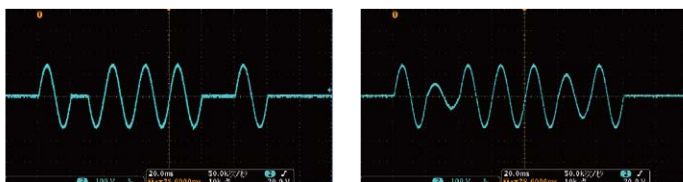

Output frequency up to 10-5000 Hz

Output variable rate of voltage or frequency is adjustable IT7600 series high-power AC / DC power supply output frequency is adjustable during 10-5000 Hz. IT7600 series have a wide range of applications, which not only to meet the low-frequency demand for general commercial industry, but also can be used for high frequency aerospace

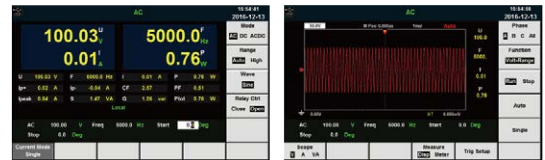

IT7600 series allows users to set their own output fluctuation rate of voltage or frequency, so that the voltage or frequency regularly reach these values step by step. It is more accurate to verify the product operation scope and also can reduce surge current of DUT when starting up.

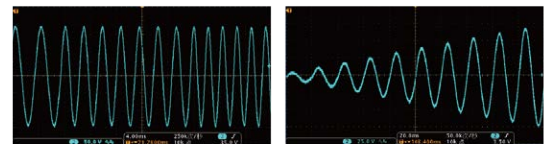

Output frequency is incremented

Output voltage is incremented

Achieve AC, DC, AC+DC output modes

AC+DC can achieve offset simulation of DC Voltage IT7600 series high-power AC / DC power supply can achieve AC, DC, AC + DC output modes, not only provide pure AC / DC output, but also can provide AC + DC output mode to expand application and test DC bias components.



AC

DC

AC+DC

* (IT7630, IT7632, IT7634, IT7636) only support AC mode

Support CSV file to import waveforms

- Import a CSV file via the USB interface to generate a waveforms output

The user can edit the waveform output by the panel LIST function or can import a CSV file via the USB interface to generate waveform output. At the same time, IT7600 series provides external $\pm 10\text{ V}$ analog interface, users can choose separate AM and FM amplitude modulation to receive external signal source.

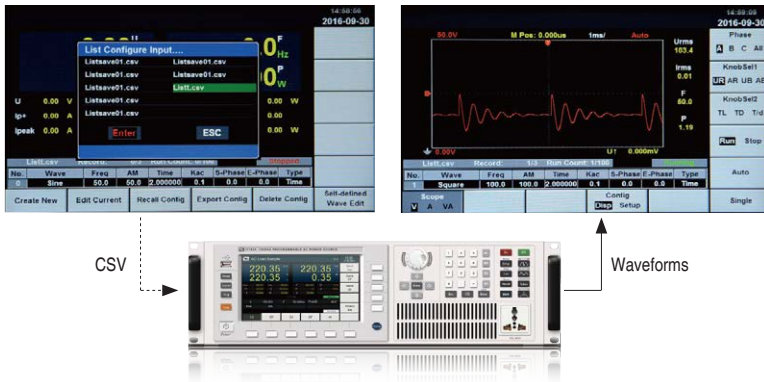

- Application: List mode can simulate civil use AC network

Users can edit and simulate the situation of various power interference by IT7600 series high-power AC / DC power supply panel or program-controlled software.

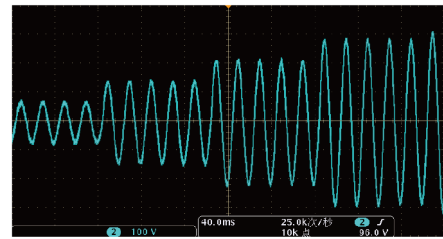

STEP

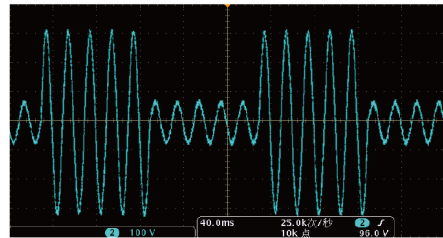

LIST

List mode

- List mode can simulate civil use AC network, achieve simulation of instantaneous power interruption

IT7600 series high-power AC / DC power supply provide users a simple way to achieve the output parameters changing gradually or continuously through STEP mode and LIST mode. The amplitude of output voltage, frequency, phase, waveform and other parameters can also be output by controlling the internal trigger or external trigger of the instrument. Thus you can simulate a variety of power instantaneous power interruption, surge, ramp and other characteristics.

- Application: Simulation of instantaneous power interruption

IT7600 series high-power AC / DC power supply can also effectively simulate a variety of power off.

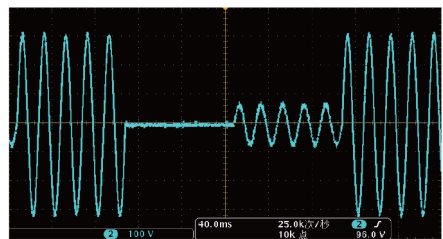

Surge wave

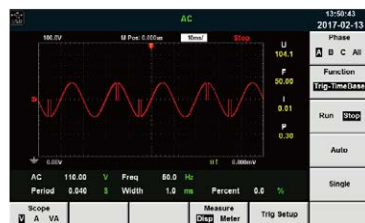

Trap wave

Strong harmonic simulation capability

- Up to 50th harmonics

IT7600 series high-power AC / DC power supply has strong harmonic simulation capability, up to 50th harmonics.

Within 10-500 Hz, IT7600 can measure 50th voltage and current harmonic. Exceed 500 Hz, IT7600 can test 20th voltage and current harmonic.

Built-in abundant waveform database

- Recall by menu and display the selected waveform on the LCD screen

IT7600 series high power AC / DC power supply provide built-in a variety of different types of waveforms, such as triangle wave, sine wave, surge at peak, trap wave, and other waveforms, the user can recall by menu and display the selected waveform on the LCD screen.



Square wave



Sawtooth wave



Triangle wave



Sine waveform

Strong harmonic analysis function

- Voltage / current harmonic measurement

IT7600 high-power AC power supply is with powerful function in harmonic analysis, including harmonic measurements for voltage and current. For harmonic measurements, when frequency is 10-500 Hz, IT7600 can test 50th; when it's above 500 Hz, then 20th. In harmonic mode, it can do tests for U / I THD

(Voltage / Current Total Harmonic Distortion) factors, as well as Phase tests. Besides, IT7600 can do multiple harmonic measurements, the results are displayed in list or histogram, so that the test results are more clear.

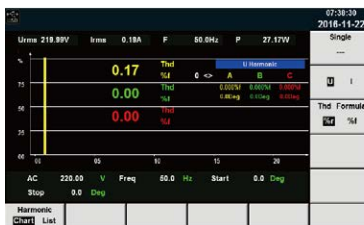

Built-in powerful AC power meter

- Built-in powerful AC power meter

IT7600 series high power AC / DC power supply is equipped with 16-bit high-precision measuring design, with the built-in powerful AC power meter, it can accurately measure a variety of parameters, including rms voltage, rms current, output frequency, active power, and power factor. Users need no more a power meter, save the test cost, and shorten the complex connection operation time.

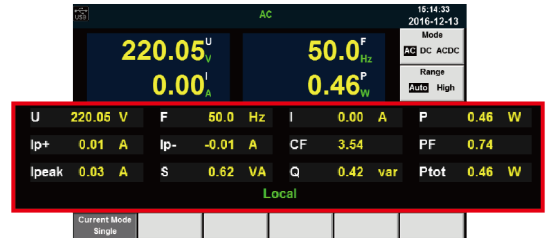

Support single / three-phase output

- Simulate unbalanced three phase output

The IT7600 high performance programmable AC power supply can be connected in parallel with multiple single units to test three-phase AC power supplies. Both Y-type and Δ-type connections are available in terms of your needs. The IT7600 series can simulate three-phase unbalance when achieving three-phase output, which helps to cover more applications fields.

When IT7600 series realize three-phase output, IT7600 can simulate unbalanced three-phase output, expanding the scope of application.

Strong master-slave paralleling function

- Using power in more flexible way

The IT7600 AC / DC power supply models provide the strong (Master-Slave) parallel operation function, which enable users to extend the current / power output ability to save cost. During parallel connection operation, it only requires the setting on Master unit, and the slave unit will be controlled by the master unit automatically. This function greatly simplifies the paralleling operation.

IT7600 series have built-in synchronous On / Off input and output signals, which ensures the synchronization and equalized current output on multi modules synchronously.

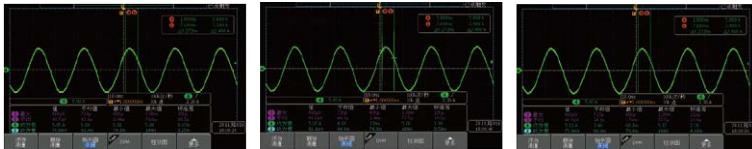

IT7600 after paralleling of 3 sets, each unit will share the test current averagely

Vector function

Display each phase harmonic parameter and single harmonic

IT7600 series high power AC power source realize vector function under three-phase mode. Users only need to press the [Vector] key on the front panel, so that can enter the vector measurement interface.

Users can observe the vector diagram of the harmonic function parameter values in each phase, and select the single harmonic to be displayed by rotating the knob.

Settable start / stop phase angle of output waveform

- Angle range: 0~360°

IT7600 series high-power AC / DC power supply can set the start phase and stop phase of the sinusoidal output waveform to meet the test requirements under different test conditions. The start phase and the stop phase are set from 0 to 360°. Inrush current of products can be tested by adjusting the phase angle, which can be applied to test switching impact current and debug rectifiers.

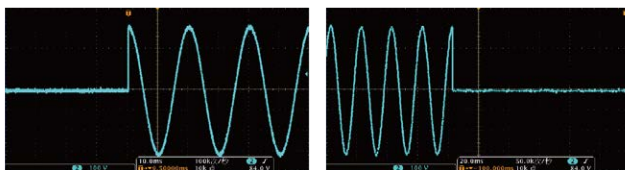

90° starting phase angle

90° stop phase angle



IT7300 Programmable AC Power Supply

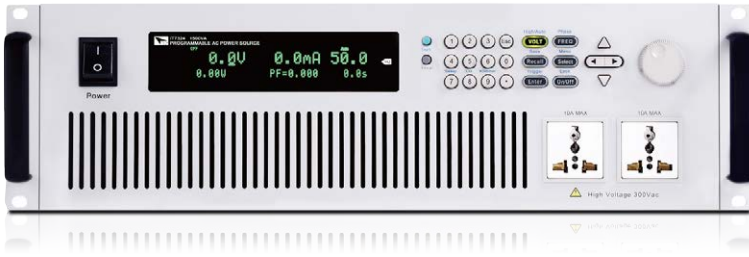

Applications

Motor industry, Illumination, Aviation, Lab testing, Production linetest, etc.

Feature

- Precise Linear amplification technology, low noise, high stability
- High power density design, 1500VA for 3U size, save installation space
- Adjustable frequency:45Hz-500Hz
- Adjustable phase angle: 0-360°
- Settable output slew rate of voltage and frequency
- High current crest factor for surge current testing
- TRIAC Dimmer dimming / governor simulation function
- Output the changed synchronous TTL signal
- LIST mode for testing power perturbation (PLD) simulation
- Simulate the surge, trap waveform
- Voltage dip, short interruption and voltage change simulation
- Measure various electrical parameters, including RMS voltage / current, actual power, power factor, VA (apparent power), peak current and other parameters
- Measurement resolution 0.01W / 0.1mA, meet Energy Star standard requirement
- Built-in RS-232, USB and LAN (support SCPI protocol)
- Support three devices connection through System Bus to achieve three-phase AC power function
- OCP,OVP,OTP,OPP

* For any GPIB interface option request, check with ITECH for availability

In order to meet the wider range of AC power supply and more complex change characteristics, engineers need more powerful and stable AC power supply to simulate the actual working environment. IT7300 series is the best solution in this area. IT7300 series can be widely applied in the electronics and electrical industry, lighting, R&D specification's verification, laboratory testing and factory production online test etc.

Model	Voltage	Current	Power	Phase	Size
IT7322	150/300	6/3	750	1φ	3U
IT7324	150/300	12/6	1500	1φ	3U
IT7326	150/300	24/12	3000	1φ	6U
IT7322H	250/500	3/1.5	750	1φ	3U
IT7324H	250/500	6/3	1500	1φ	3U
IT7326H	250/500	12/6	3000	1φ	6U
IT7322T	150/300	6/3	2250	3φ	15U
IT7324T	150/300	12/6	4500	3φ	15U
IT7326T	150/300	24/12	9000	3φ	27U
IT7322HT	250/500	3/1.5	2250	3φ	15U
IT7324HT	250/500	6/3	4500	3φ	15U
IT7326HT	250/500	12/6	9000	3φ	27U

Linear amplification technology

IT7300 Series AC Power Supply adopts advanced and high-precision linear amplification design to provide low noise and high stability output. This technology has high-speed response characteristics, stable low noise, it can simulate the abnormal power line, instantaneous voltage rise, drop and power off, and can be applied to ATE and so on.

Built-in AC power meter

IT7300 series directly shows voltage RMS, current RMS, frequency, active power, power factor from panel without external power meter, saving the test cost and complex connection operation time.

Adjustable phase angle

Users can set the start and stop phase angle within range of 0-360°. This function is widely used for startup and shutdown current inrush impact test or various rectifier performance tests.

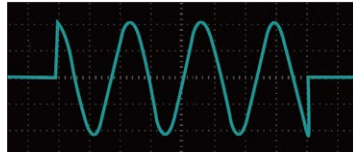

TRIAC Dimmer simulation function

ITECH is the pioneer of TRIAC Dimmer function. This function is used to do dimming and speed regulating test for lamp or electric motor to ensure the products work well when controller of dimming and speed regulating is needed.

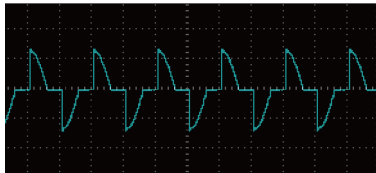

Leading Edge

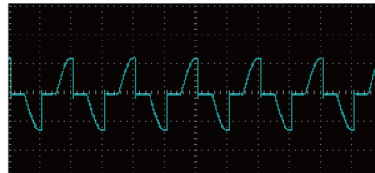

Trailing Edge

Sweep function

This function tests efficiency of switch power supply and gets voltage and frequency value at max power. It could change voltage and frequency by setting start voltage value, end frequency, stepping frequency and time of each step. It saves 10 files max. Voltage, frequency and current of max power will be displayed when the test is over.

Support Three-phase Parallel function

IT7300 series AC source can achieve three-phase without requiring external accessories, users can directly connect into three-phase through the back of the SYSTEM BUS, set one of them as master, the rest are slaves. The slave sends synchronous clock control signal according to each cycle of the DDS inside the device, so that the phase difference is always maintained at 120 ° and does not deviate greatly in long time running. It is flexible to meet the increase or decrease requirements of production line aging test machine numbers.

List function

IT7300 series has built-in DDS waveform generator, very flexible waveform simulation function. Users can directly set the required power waveform through the panel keys, to simulate transient power off, surge, trap, specific phase angle on or off, AC sine wave amplitude and frequency range and other characteristics.

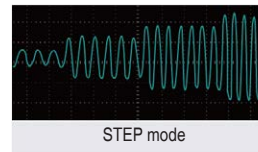

STEP mode

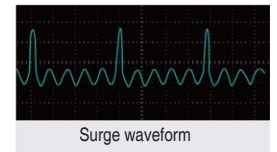

Surge waveform

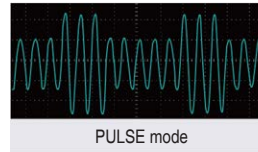

PULSE mode

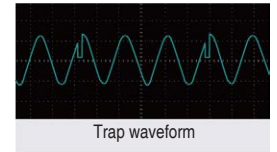

Trap waveform

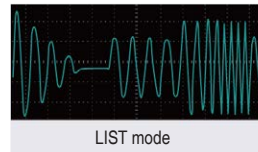

LIST mode

IT-N6900 Programmable DC Power Supply



Power Supply

Feature

- 4.3" HD LCD
- Voltage: 60V, 150V
- Power: 850W, 1500W, wide range output
- Two current ranges, 1µA current resolution
- Lower ripple and noise
- Using a new type of transformer, lighter, higher efficiency and stability
- Faster voltage rise and fall
- With CC, CV priority, suitable for a variety of DUT's

IT-N6900 DC power supply has 60V and 150V, 850W and 1500W output. It features as black panel and HD screen, low ripple and noise. It can provide stable and pure DC power, two current ranges, up to 1µA current resolution. It has CC and CV priority settings, new Foldback protection. It is well used for the test of DC-DC, semiconductor lasers, automotive electronics, communication electronics, motors, PV modules and so on. IT-N6900 series supports SCPI and LabVIEW drivers, built-in USB/LAN/digital IO communication interface, optional GPIB/RS232/analog IO, suitable for remote control and system integration, and can be used in R&D, production lines, universities, etc.

- Remote Sense function
- Support OVP, UVP, OCP, OPP, OTP, Foldback protection function
- Built-in USB/LAN/Digital IO communication interface, optional GPIB/RS232/analog IO
- Support SCPI, LabVIEW programming
- Trend analysis, monitor the voltage, current and power of the DUT in time

Model	Voltage	Current	Power
IT-N6952	60V	25A	850W
IT-N6962	60V	25A	1500W*1
IT-N6953	150 V	10A	850W
IT-N6963	150V	10A	1500W*1
IT-E177	RS232& analog10A		Optional
IT-E176	GPIB		Optional

*1 The power output is 850W under 110Vac input

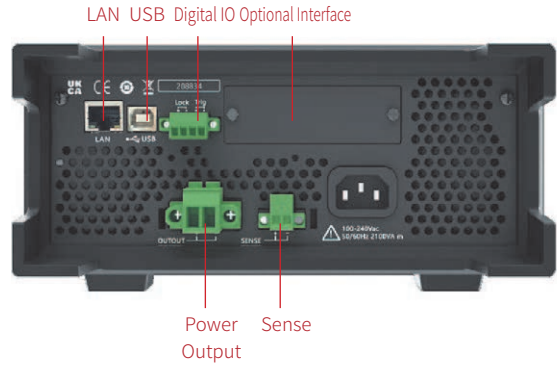

Applications

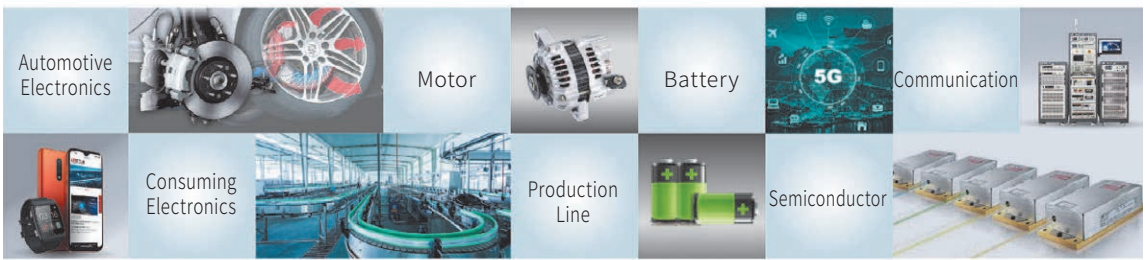

Data logging function (Trend Analysis)

IT-N6900 supports trend analysis function, which allows the end users observe voltage, current and power online for a long time. Users can save test data in U disk, and the time interval of data recording can be set, which is especially suitable for long-term aging test of production lines or R&D laboratories. HD screen with graphic display, users can observe the abnormal situation of the test in real time.

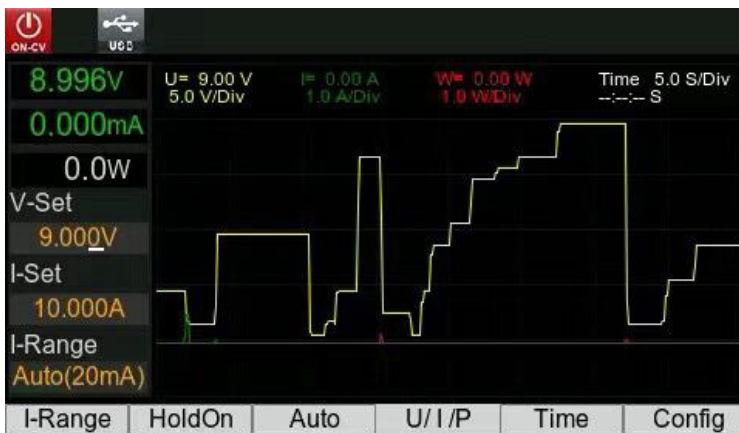

List programming

The LIST programming function of IT-N6900 can provide a maximum of 100 steps of sequence output, and a total of 10 sequence files can be edited. The user can generate various output change sequences by editing the steps such as voltage, current, time and whether to cycle the steps of each single step. The parameters include time units.

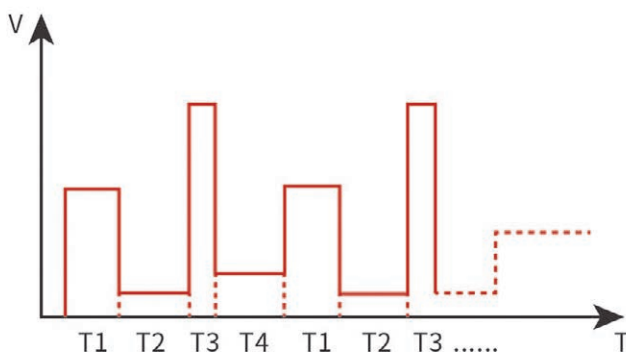

CC&CV priority

IT-N6900 has CC/CV priority function, which is suitable for complex applications with high speed or no overshoot test requirements. In CV priority mode, you can get faster voltage rising. In CC priority mode, the output current has no overshoot, which can be used to test the DUT of constant current operating characteristics. It is good for applications such as laser testing, integrated circuit testing, charge and discharge testing, power transient simulation and characterization of automotive electronics, etc.

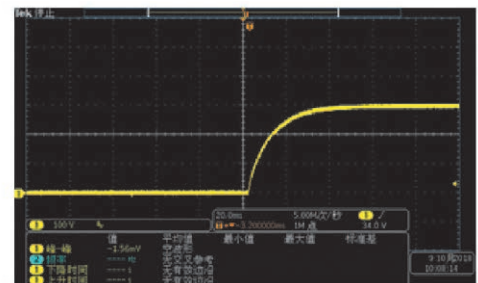

CV priority
no voltage overshoot

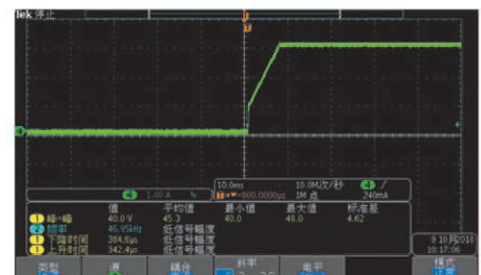

CC priority
no current priority

Foldback

IT-N6900 supports multiple protection functions such as OVP/UVP/OCP/OPP/OTP/Foldback. The Foldback protection function is mainly used to turn off the output when the power supply CV/CC is switched, so as to protect the DUTs which are sensitive to voltage and current overshoot. You can set the working mode and the protection delay time. If the current working mode is changed, the protection will be triggered when the time is up and the output will be turned off.

IT-M3140 Programmable DC Power Supply



IT-M3140 Programmable DC Power Supply is specially designed for testing, production, R&D lab and ATE integration. It is only 2U half rack, but can output power up to 1850W and 3000W, and voltage output from 30V to 1200V. It has three output modes of constant voltage, constant current and constant power. Automatic wide-range output enables it to achieve a wider output voltage and current range at full power output, meeting a wider range of testing requirements and greatly saving equipment purchase costs.

Power Supply

Feature

- Only 2U half rack, 1850W/3000W
- 30V-1200V, 150A
- Three output modes: CV/CC/CP
- CC/CV priority to avoid current overshoot
- Fast dynamic response: <1ms
- According to the voltage and current waveform output programmed by LIST, the rising and falling slopes are adjustable
- Fold back, UVP/OVP, UCP/OCP, OPP, OTP, inhibit protection, more secure and reliable
- The Sense protection circuit combined with software and hardware can effectively detect Sense reverse connection and missing connection, and protect the DUT
- Standard USB/LAN, optional RS232 & analog, GPIB, easy to integrate

Not only that, IT-M3140 is a DC power supply integrating high stability, fast response (<1ms), high-level protection functions and LIST programmable functions. This series is equipped with a standard USB/LAN interface, and can be used with ITECH's free PV3140 software to easily realize remote control and data storage, and is easy to integrate. IT-M3140 can be widely used in semiconductor device ATE, burn-in integration, testing and certification, power module and automotive electronics and other fields.

Stable output



9 protection modes



2U half rack

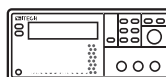

Fast dynamic response <1ms

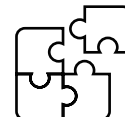

APPLICATION

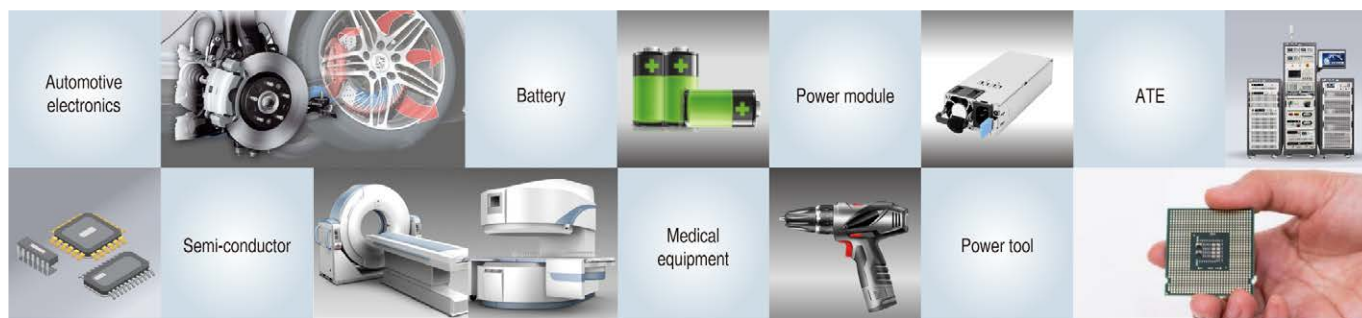

Model	Parameter Specifications (3000W)	Model	Parameter Specifications (1850W)
IT-M3141	30V/150A/3000W	IT-M3131E	30V/150A/1850W
IT-M3142	80V/80A/3000W	IT-M3132E	80V/80A/1850W
IT-M3143	150V/40A/3000W	IT-M3133E	150V/40A/1850W
IT-M3144	300V/20A/3000W	IT-M3134E	300V/20A/1850W
IT-M3145	600V/10A/3000W	IT-M3135E	600V/10A/1850W
IT-M3146	1000V/6A/3000W	IT-M3136E	1000V/6A/1850W
IT-M3147	1200V/5A/3000W	IT-M3137E	1200V/5A/1850W

Size: 2U half rack

AC input range (single-phase: L, N, PE) : A. 110Vac±10%, power down to 1500W B. 192Vac~264Vac, full power output of all models

Optional accessories

Description	Model	
Rack mounting kit	IT-E158A	For 2 units installed side by side in ITECH standard cabinet
	IT-E158B	For 2 units installed side by side in non-ITECH cabinet
	IT-E158C	For single unit installed in ITECH standard cabinet
	IT-E158D	For single unit installed in non-ITECH cabinet
Communication interfaces	IT-E176	GPIB communication card
	IT-E177	RS232 & Analog card

Fast dynamic response < 1ms

IT-M3140 series has high speed dynamic response characteristics, when the external load fluctuations, the power supply can quickly restore stability within <1ms, thus makes the test more reliable.

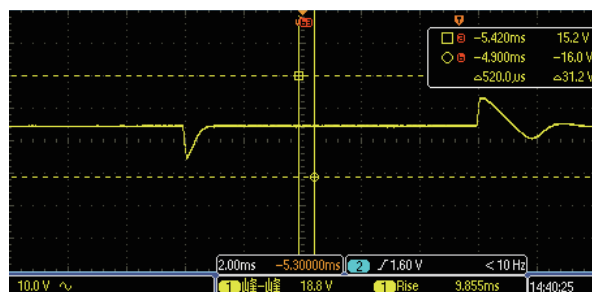

LIST mode simulates various power supply disturbance waveforms

IT-M3140 series provides LIST programming mode. In this mode, users can generate arbitrary DC voltage disturbance waveforms, such as instantaneous voltage drop or voltage rise slowly, by setting parameters such as working steps (max100 steps), output voltage/current per step, single step duration (0.001s-3600s), rising and falling slopes, etc., to fully verify the anti-interference performance of DC loads. It is suitable for testing products such as DC-DC power modules, motor drivers, and battery-powered household appliances.

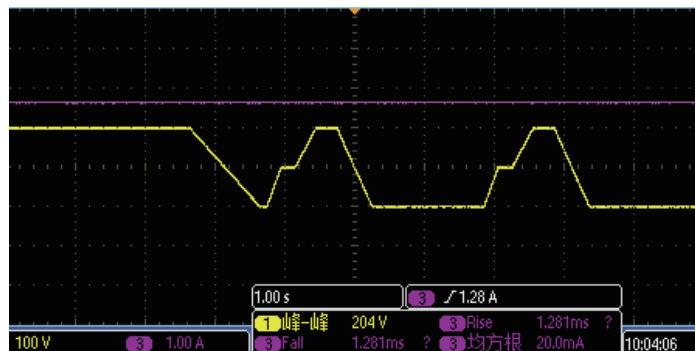



CC/CV priority function to effectively suppress current overshoot

The IT-M3140 series has a CC/CV priority function to help users solve a variety of demanding problems in long-term test applications. By changing the CC/CV priority and loop speed settings, users can obtain voltage high speed mode or current no overshoot mode, making the test more flexible, since it is suitable for current-sensitive laser testing, and can also meet the application scenario of rapid voltage dips.

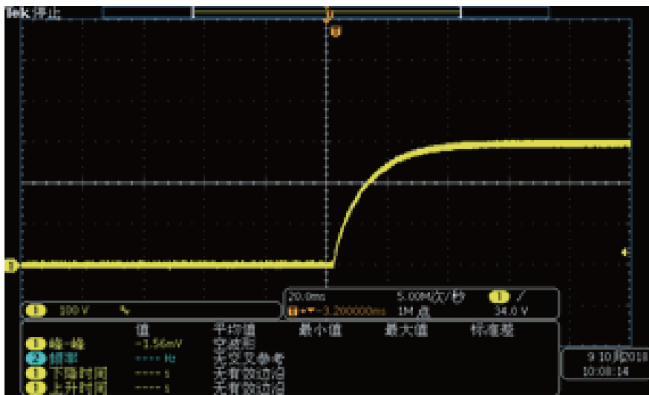

Start-up inrush current over current range, high-speed build-up voltage electric
CV Priority

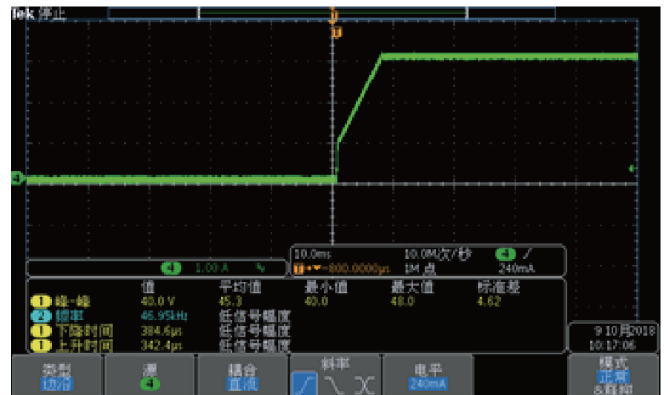

Seamless battery charging and discharging at high speed with no overshoot switching
CC Priority

9 protection modes to enhance test security

To further enhance the reliability and safety of product testing, the IT-M3140 series offers nine protection modes. In the traditional over / under voltage, over / under current, over power protection on the basis of the additional Fold back, Inhibit and Sense reverse connection protection function, so that not only can effectively reduce the power mode switching instantaneous overshoot, while avoiding the sense wrong connection or leakage caused by test abnormalities. With the Inhibit output ban / interlock function, making the test more secure and reliable.



IT-M3900B Regenerative Power System



Applications

Industrial power supply modules, Electric Vehicles, Small/Medium Power Motors, 5G communication and data center

Feature

- 2 in 1 unit - a bidirectional power supply and a regenerative load
- Compact design, 1U@6kW, 2U@12kW
- Voltage range: 10~1500V
- Current range: -720A~1020A
- Power range: ±12kW
- Bidirectional energy flow between the DUT and the grid, current seamless switching
- Master/slave parallel connection keep good performance while power extension*1
- Efficient power regeneration - reduce cost of electricity and cooling
- CC/CV priority
- Adjustable output impedance
- Battery charge and discharge test
- Battery simulation
- Partial pre-compliant with LV123, LV148, DIN40839, ISO-16750-2, SAEJ1113-11, LV124 and ISO21848 automotive testing standards*2
- Simulation of dynamic driving conditions, up to 10 million points
- 8 operation modes under Source mode: CC/CV/CW/CR/CC+CV/CV+CR/CR+CC/CC+CV+CW+CR
- Built-in USB/CAN/LAN/digital IO interfaces, Optional GPIB/Analog&RS232

*1 If 1U models>16, 2U models>8, pls. contact ITECH.

*2 Not available for 10V models

The IT-M3900 series combines four series of DC power supplies, bi-directional power supplies, regenerative power system and regenerative electronic load. It continues the ultra high power density design of M series, with a maximum power of 6kW, current of 510A and voltage up to 1500V in 1U, comfortable system scalability, and a small physical size could save extra space and fully meet the stringent requirements of various requests with the multi-functional, high energy-saving, high safety and high stability product design. IT-M3900B regenerative power system feature two-in-one, which could use as a bidirectional DC power supply, also act as an independent regenerative load. One-button-switch between source and load mode, a unique and decisive feature for the user groups that works in different applications such as battery, energy storage, electric vehicle, Green energy and some ATE fields.

Battery simulation function

IT-M3900B unique bidirectional design and variable output impedance makes it easy for the users to set voltage/capacity/internal resistance/SOC quickly to define battery matrix quickly from the front panel, to simulate the charge/discharge characteristics of battery and assist with other tests. ITECH provides optional BSS2000 battery simulation software, then users can self-define the battery curve by setting common parameters, also can set battery initial capacity to verify the DUT characteristics under different battery status. Meanwhile, BSS2000 supports importing matlab battery matrix or CSV. file with battery charging and discharging curve, so as to simulate real battery charge and discharge characteristics.



BSS2000 battery simulation software interface

Voltage	Model		Current	Power		Current	Power	Size
10V	IT-M3901B-10-170	source	-120-170A	-1200-1700W	load	3-120A	12-1200W	1U
	IT-M3903B-10-340		-240-340A	-2400-3400W		4-240A	40-2400W	1U
	IT-M3905B-10-510		-360-510A	-3600-5100W		6-360A	60-3600W	1U
	IT-M3910B-10-1020		-720-1020A	-7200-10200W		12-720A	120-7200W	2U
32V	IT-M3902B-32-80	source	±80A	±2kW	load	80A	2kW	1U
	IT-M3904B-32-160		±160A	±4kW		160A	4kW	1U
	IT-M3906B-32-240		±240A	±6kW		240A	6kW	1U
	IT-M3912B-32-480		±480A	±12kW		480A	12kW	2U
80V	IT-M3902B-80-40	source	±40A	±2kW	load	40A	2kW	1U
	IT-M3904B-80-80		±80A	±4kW		80A	4kW	1U
	IT-M3906B-80-120		±120A	±6kW		120A	6kW	1U
	IT-M3912B-80-240		±240A	±12kW		240A	12kW	2U
300V	IT-M3902B-300-20	source	±20A	±2kW	load	20A	2kW	1U
	IT-M3904B-300-40		±40A	±4kW		40A	4kW	1U
	IT-M3906B-300-60		±60A	±6kW		60A	6kW	1U
	IT-M3912B-300-120		±120A	±12kW		120A	12kW	2U
500V	IT-M3902B-500-12	source	±12A	±2kW	load	12A	2kW	1U
	IT-M3904B-500-24		±24A	±4kW		24A	4kW	1U
	IT-M3906B-500-36		±36A	±6kW		36A	6kW	1U
	IT-M3912B-500-72		±72A	±12kW		72A	12kW	2U
800V	IT-M3902B-800-8	source	±8A	±2kW	load	8A	2kW	1U
	IT-M3904B-800-16		±16A	±4kW		16A	4kW	1U
	IT-M3906B-800-24		±24A	±6kW		24A	6kW	1U
	IT-M3912B-800-48		±48A	±12kW		48A	12kW	2U
1500V	IT-M3906B-1500-12	source	±12A	±6kW	load	12A	6kW	1U

Power Supply

One button switch, bidirectional and regenerative

Different from other bidirectional power supplies, IT-M3900B series is a regenerative power system which combines two devices into a 1U unit. It is both a bidirectional DC power supply and also a regenerative DC electronic load. You can switch between Source and Load with one button on the front panel. IT-M3900B not only saves space and equipment purchasing cost for you, but also enables you to connect DUT easily.



It can switch seamlessly between source and sink mode fast and continuously, which avoids voltage or current overshoot effectively. IT-M3900B can be well applied to battery test, cell packaging equipment test, battery protection board test, etc.

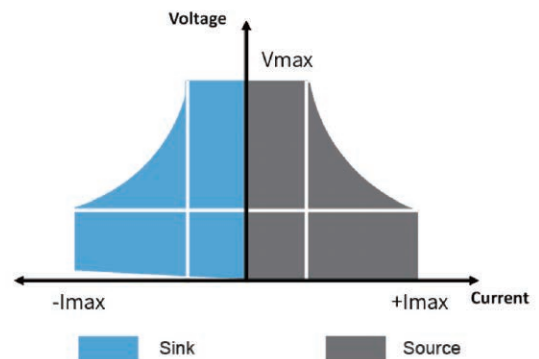

CC & CV priority

CV & CC priority helps customers effectively and flexibly solve their various tough problems in test applications request for high speed and no over-shoot power supplies. Customers can select CV or CC priority to adjust the speed of the loop circuit, to decide output with the high-speed voltage or current with no overshoot. It is applicable for high-power integrated circuit test, charging/ discharging test and the transient simulation/ characteristic test of automotive electronics.

Battery charge/discharge Testing

IT-M3900B series are with unique bidirectional design, variable output impedance, and four working modes of CC/CV/CP/CR under load mode, so it can simulate battery charging and discharging characteristics, set various testing conditions and process testing data, so as to be applicable for charging and discharging testing for various kinds of portable batteries. IT-M3900B series are with unique bidirectional design, variable output impedance, and four working modes of CC/CV/CP/CR under load mode, so it can simulate battery charging and discharging characteristics, set various testing conditions and process testing data, so as to be applicable for charging and discharging testing for various kinds of portable batteries.

With optional ITS5300 battery testing software, it can do the below testing items:

- Road conditions simulation
- Charging & discharging characteristics testing
- Cycle life testing
- Consistency testing
- DCIR testing
- Temperature testing
- Capacity testing
- Life testing
- Reliability testing
- Overcharge/over discharge endurance testing

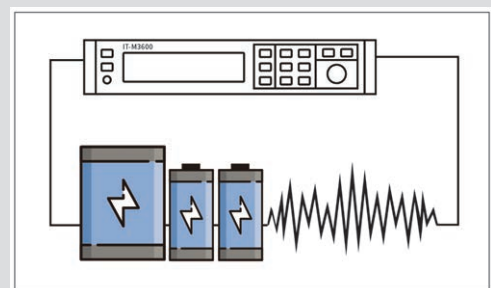

Wide range output

There are 25 models included in IT-M3900B series. The output voltage ranges from 10V to 1500V and the maximum output current of a single unit can reach 1020A. The wide-range output design provides more voltage and current combinations than conventional fixed-range output DC power supplies, which is more flexible. Just a single unit can cover a wide range of applications which makes it easy to build power systems and largely save room for you at the same time.

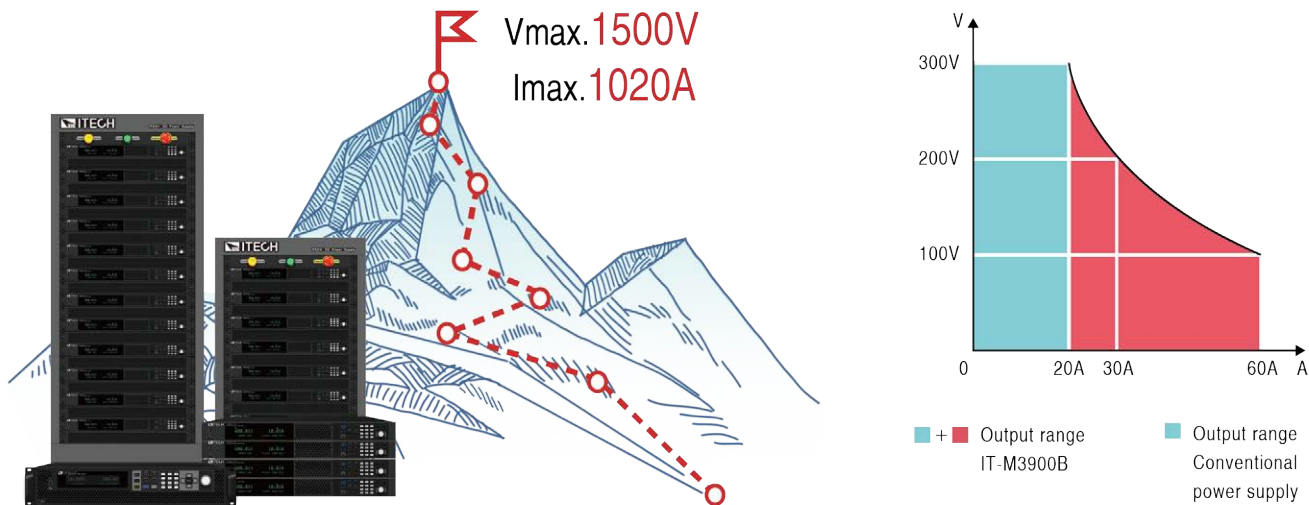

Power Supply

Power regenerative and eco-friendly

With the power regeneration function, IT-M3900B can feed back up to 95% power instead of consuming it as heat. It not only save your cost of electricity, HVAC and cooling infrastructure, but also help to reduce carbon emission and impact on the environment. In addition, IT-M3900B has the function of automatic grid detection, which can detect phase voltage and frequency in real time and synchronizes with the grid to make energy regeneration automatic and safe.

Production facility : 24Hr/day x 7 work days x 52 weeks

R&D lab : 8Hr/day x 5 work days x 52 weeks

Power	Electricity cost saved (appr. USD/year)	CO2 emission reduced (appr. ton/year)
6 kW	6,971	50
12 kW	13,943	99
36 kW	41,828	298
96 kW	111,541	794

Power	Electricity cost saved (appr. USD/year)	CO2 emission reduced (appr. ton/year)
6 kW	1,747	12
12 kW	3,494	24
36 kW	10,483	71
96 kW	27,955	189

* The data is based on :

1. approximate electricity price 0.14USD/kWh for industry facility in California
2. 1kWh power consumption ≈ 0.997 CO emission

* The extra cost of air conditioning is not included.

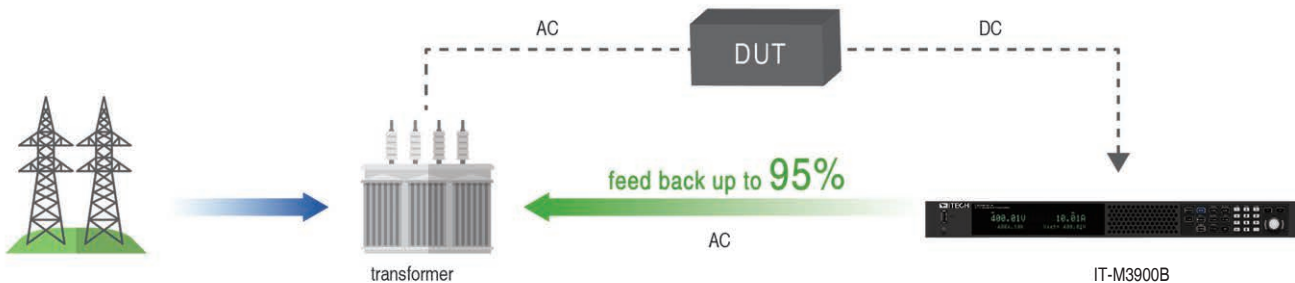

Pre-compliant with multiple standards for EV component testing

Power transients often happen during vehicle start-up and driving. To make sure that the automotive electronic components can withstand it, it's necessary to simulate the worst conditions during the test. IT-M3900B has built in partial voltage curves of pre-compliant standard, including LV123, LV148, DIN40839, ISO-16750-2, SAEJ1113-11, LV124 and ISO21848. Users can easily recall various waveforms directly. You don't need to program by yourself or purchase any additional software.

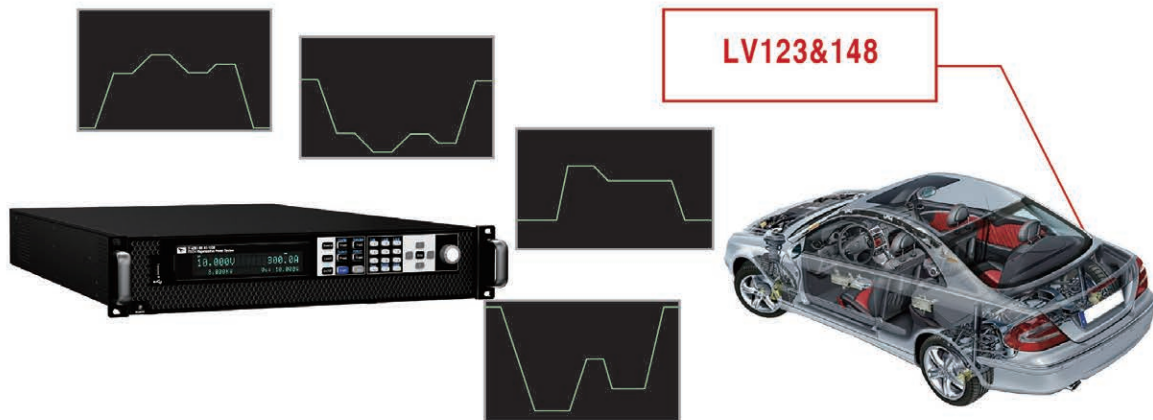

Multiple operation modes

IT-M3900B provide CC/CV/CW/CR modes under source/load mode.

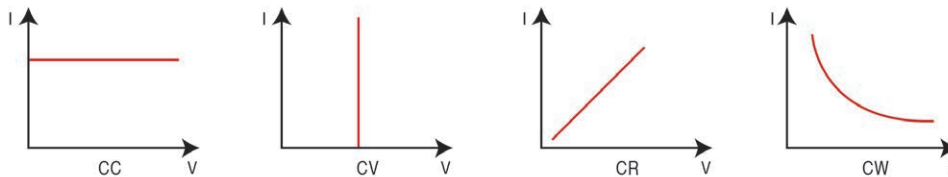

IT-M3900B also provide CC+CR/CV+CR/CV+CC/CC+CV+CW+CR four complex modes under Load mode, adapt to multiple applications.



CC+CR mode can be applied to OBC feature test of voltage limit, feature test of current limit, constant voltage accuracy test, constant current accuracy test, to prevent over current protection.

CV+CR mode can be applied to simulate LED light, test LED power, LED current ripple parameters.

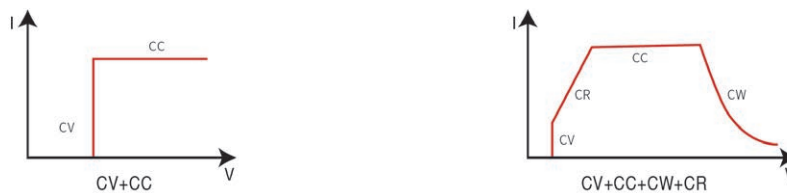

CV+CC mode can be applied to simulate battery, test charging station or car charger, the maximum loading current is limited when the CV is working.

CV+CC+CW+CR mode can be applied to test lithium-ion battery charger, to gain complete V-I charging curve. In addition, when protection circuit of DUT is damaged, it can auto switch to avoid damage.



IT-M3900C Bidirectional Programmable DC Power Supply



Applications

PV energy storage, Super capacitor/Battery, Small/Medium Power Motors, Electric Vehicles

Feature

- Compact design, power up to 6kW in 1U space, power up to 12kW in 2U space
Voltage range: 10-1500V
- Current range:-720A~1020A
- Power range:+/-12kW
- Wide range of output design, one unit can be used as multiple power supplies
- Bidirectional energy flow between the DUT and grid, seamless switching across quadrants
- With simple master/slave parallel connection, expand power while maintaining performance*1
- Efficient and environmentally friendly energy regenerative, effectively reducing the electricity and cooling costs
- CC/CV priority
- Adjustable output impedance
- Battery charging and discharging test
- Battery simulation, define the battery model
- Dynamic curve simulation function up to 10,000,000 points
- Built-in voltage curves comply with LV123, LV148, DIN40839, ISO-16750-2, SAEJ1113-11, LV124 and ISO21848 automotive standards*2
- Support photovoltaic I-V curves simulation function*3
- List function
- Support CC/CV/ CW/CR in sink mode
- Support CC/CV/CW in Source mode, and can simulate DC output internal resistance
- Multiple protection functions: OVP, \pm OCP, \pm OPP, OTP, power failure protection, anti-islanding protection
- Automatic detection of power grid status to realize reliable grid connection function
- Pre-charge function, to prevent overshoot of DC loading current
- Standard build-in USB/CAN/LAN/digital IO communication interface, optional GPIB/analog & RS232

*1 If 1U models>16, 2U models>8, pls. contact ITECH.Parallel connection is not recommended under PV simulation function

*2 Not available for 10V models

*3 Only available for 85V models

IT-M3900 series integrates the features of a DC power supply, a bi-directional power supply, a source and load system, and a regenerative electronic load in one. It keeps the advantages of high power density design of M series, power up to 6kW, current up to 510A, and voltage up to 1500V within one 1U unit, effectively reducing the equipment occupation space and cabinet time. wide-range models could meet different test requirements while matching with multi-functional, high energy-saving, high-safety, and high-stability product design, let the customer be confident to face a variety of complex testing, improving the products competition ability.

IT-M3900C is a regenerative bidirectional programmable DC power supply, it is not only a stand-alone bidirectional DC power supply but also can be used as a regenerative electronic load, to absorb the consumed energy and feedback cleanly to the grid. The high-efficiency energy feedback efficiency not only saves electricity consumption and heat dissipation costs but also does not interfere with the operation of the power grid. IT-M3900C provides high accuracy output measurement, high reliability, high safety, and abundant measurement functions. Which makes IT-M3900 meet customers' high accuracy automatic ATE testing requirements, while extensively used in aspects of automotive electronics, new energy vehicles, photovoltaic energy storage, intelligent industrial equipment, battery simulation, etc.

Applications

PV energy storage

Grid-tied inverters, Energy storage converter, Residential solar battery storage system

Super capacitor/Battery

Cell, Battery pack, Capacitor

Small/Medium Power Motors

Drones, Power tools, Electric Motorbikes

Electric Vehicles

BOBC, DC-DC Modules, Automotive Electronic Devices

	Model	Current	Power	Size
10V	IT-M3901C-10-170	-120~170A	-1.2~1.7kW	1U
	IT-M3903C-10-340	-240~340A	-2.4~3.4kW	1U
	IT-M3905C-10-510	-360~510A	-3.6~5.1kW	1U
	IT-M3910C-10-1020	-720~1020A	-7.2~10.2kW	2U

	Model	Current	Power	Size
32V	IT-M3902C-32-80	±80A	±2kW	1U
	IT-M3904C-32-160	±160A	±4kW	1U
	IT-M3906C-32-240	±240A	±6kW	1U
	IT-M3912C-32-480	±480A	±12kW	2U

	Model	Current	Power	Size
80V	IT-M3902C-80-40	±40A	±2kW	1U
	IT-M3904C-80-80	±80A	±4kW	1U
	IT-M3906C-80-120	±120A	±6kW	1U
	IT-M3912C-80-240	±240A	±12kW	2U

	Model	Current	Power	Size
85V*1	IT-M3902C-85-40SAS	±40A	±2kW	1U
	IT-M3904C-85-80SAS	±80A	±4kW	1U
	IT-M3906C-85-120SAS	±120A	±6kW	1U
	IT-M3912C-85-240SAS	±240A	±12kW	1U

	Model	Current	Power	Size
300V	IT-M3902C-300-20	±20A	±2kW	1U
	IT-M3904C-300-40	±40A	±4kW	1U
	IT-M3906C-300-60	±60A	±6kW	1U
	IT-M3912C-300-120	±120A	±12kW	2U

	Model	Current	Power	Size
500V	IT-M3902C-500-12	±12A	±2kW	1U
	IT-M3904C-500-24	±24A	±4kW	1U
	IT-M3906C-500-36	±36A	±6kW	1U
	IT-M3912C-500-72	±72A	±12kW	2U

	Model	Current	Power	Size
800V	IT-M3902C-800-8	±8A	±2kW	1U
	IT-M3904C-800-16	±16A	±4kW	1U
	IT-M3906C-800-24	±24A	±6kW	1U
	IT-M3912C-800-48	±48A	±12kW	2U

	Model	Current	Power	Size
1500V	IT-M3906C-1500-12	±12A	±6kW	1U

*1 PV simulator

*All specifications are subject to change without notice.

CC&CV priority function

CC/CV priority can continue to help users solve various severe problems in long-term test applications to make applications that require high-speed power or non-overshoot more flexible. The CC&CV priority function of IT-M3900C allows the user to select the response speed and the loop working mode of the CC/CV loop to determine whether the output is high-speed voltage mode or non-overshoot current mode, which is suitable for high-power integrated circuit testing, charging and discharging testing, power transient simulation and characterization of automotive electronics, etc.

Wide range output

There are 25 models included in IT-M3900C series. The output voltage ranges from 10V to 1500V and the maximum output current of a single unit can reach 1020A. The wide-range output design provides more voltage and current combinations than conventional fixed-range output DC power supplies, which is more flexible. Just a single unit can cover a wide range of applications which makes it easy to build power systems and largely save room for you at the same time.

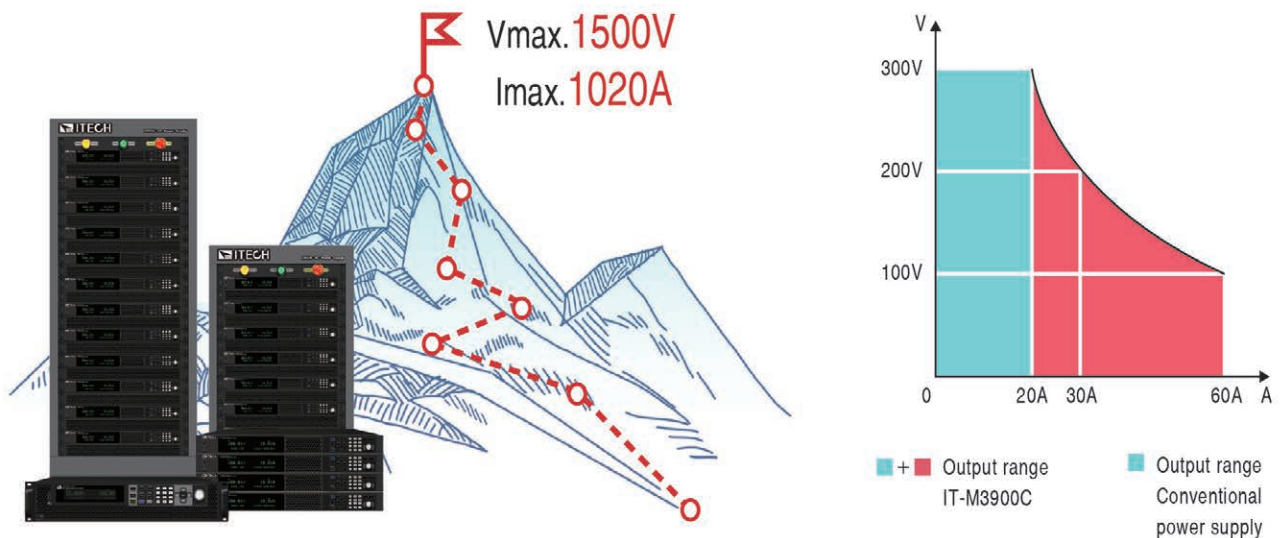

Power regenerative and eco-friendly

With the power regeneration function, IT-M3900C can feed back up to 95% power instead of consuming it as heat. It not only save your cost of electricity, HVAC and cooling infrastructure, but also help to reduce carbon emission and impact on the environment. In addition, IT-M3900C has the function of automatic grid detection, which can detect phase voltage and frequency in real time and synchronizes with the grid to make energy regeneration automatic and safe.

Production facility : 24Hr/day x 7 work days x 52 weeks

R&D lab : 8Hr/day x 5 work days x 52 weeks

Power	Electricity cost saved (appr. USD/year)	CO2 emission reduced (appr. ton/year)
6 kW	6,971	50
12 kW	13,943	99
36 kW	41,828	298
96 kW	111,541	794

Power	Electricity cost saved (appr. USD/year)	CO2 emission reduced (appr. ton/year)
6 kW	1,747	12
12 kW	3,494	24
36 kW	10,483	71
96 kW	27,955	189

* The data is based on :

1. approximate electricity price 0.14USD/kWh for industry facility in California
2. 1kWh power consumption ≈ 0.997 CO emission

* The extra cost of air conditioning is not included.

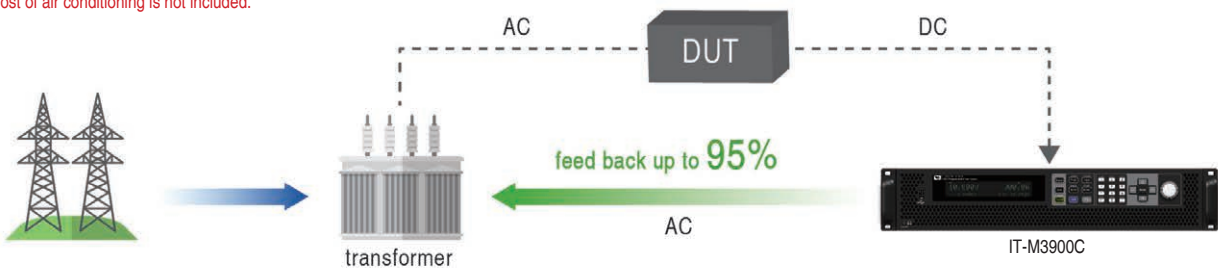

Bidirectional current, seamless switching

The IT-M3900C series integrates bidirectional power supply and regenerative load functional characteristics in one unit for continuous supply and absorption of current. It not only can realize the function of power source, but also capable of sink to load current, that realize the fast and continuous seamless switching between output and sink current , to effectively avoid voltage or current overshoot.

Compared with the conventional power supply and load test solutions, it not only saves the purchase cost, but also saves space and greatly simplifies the connection operation of the devices.

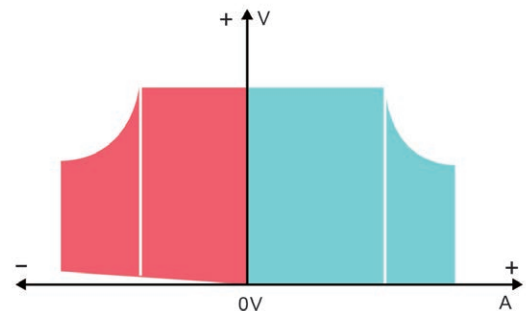

Battery simulation function

IT-M3900C series due to its unique bidirectional design and variable output impedance, the voltage, capacity, internal resistance and SOC of the battery can be set quickly through the panel to define the battery model to simulate the charging and discharging characteristics of the battery and assist in other various test. Meanwhile, users can also choose optional ITECH professional BSS2000 battery.

simulation software to set the common parameters of the battery pack to quickly establish the battery characteristic curve and the initial capacity of the battery, so as to verify the characteristics of the product in different battery states. The characteristics of the state. At the same time, BSS2000 supports users to import matlab battery modules or import the actual battery charge and discharge curve through csv file to make it more realistic.



Application: Microgrid Testing

Microgrid can be regarded as a tiny power system, and also a typical distributed power generation function system. Therefore, whether they are equipment manufacturers or professional power grid research laboratories, it is all necessary to establish simulation test requirements.

As a photovoltaic simulation source, IT-M3900C SAS can accurately simulate the I-V curve of the solar cell array and solar panels to supply power for the inverter to test the photovoltaic inverter.

As a battery simulator, IT-M3900C not only can simulate the battery to power up the inverter, but also meets the testing requirements of energy storage converters (PCS), various energy storage devices, and OBC/BOBC.

IT-M3900C also has a built-in voltage curve for standard automotive power grids, including LV123/LV148 and other new energy vehicle regulations testing, which can be applied to many automotive electrical characteristics testing without the additional purchase of software.

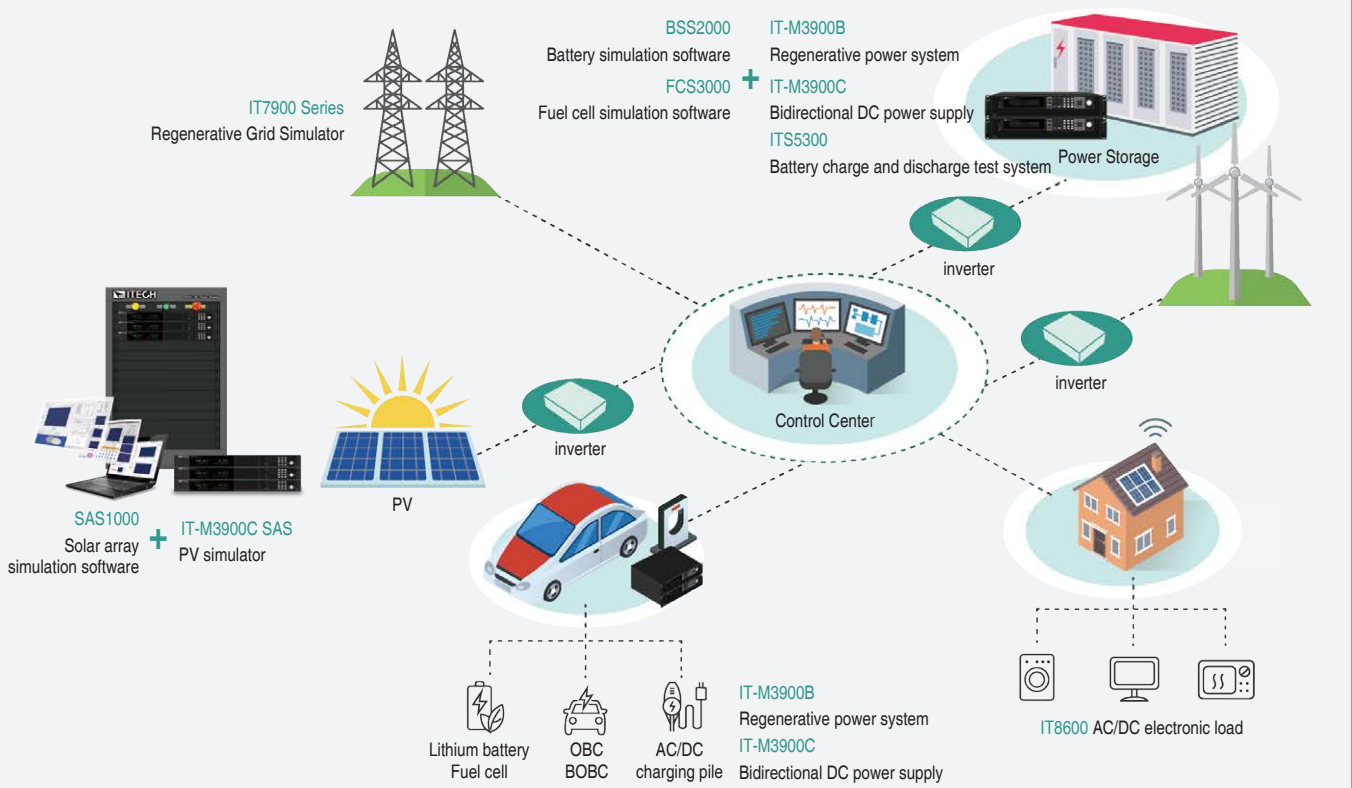

High efficiency parallel connection technology

Considering the user's convenience and versatility, IT-M3900C can use master/slave control mode to connect multiple power supplies in parallel to meet high-power testing requirements. Meanwhile ITECH fiber optic parallel technology fully solve the problems of slow speed and poor accuracy of traditional parallel methods. It is suitable for calibration and measurement, R&D lab, production line and ATE test.

* Parallel connection is not recommended under PV simulation function

The parameters will not change after parallel connection

Calibration is not requested after parallel connection

Optical fiber transfer between master and slave, guarantee perfect performance of anti-interference

Adopt Optical fiber isolation technology, effective protection of the device and DUT

Solar array simulation

IT-M3900C SAS has a built-in maximum power point tracking (MPPT) mechanism to provide solar photovoltaic curve simulation function for maximum power point tracking test of photovoltaic arrays/modules/batteries. Users can also choose optional SAS1000 solar array simulation software, which can accurately simulate the IV curve of the solar array. The built-in SAS models of EN50530, Sandia, NB/T32004, CGC/GF004, CGC/GF035 enable to simulate the IV curve output and generate reports after simply set the parameters to test the static and dynamic maximum power tracking performance of the photovoltaic inverter. User can also edit any IV curve that shields up to 4096 points to achieve dynamic cloud shielding effect, or store 100 IV curves under different illumination and temperature in the memory, and set the execution time and order of each curve, thereby To test the long-term maximum power tracking performance of photovoltaic inverters under different climatic conditions.

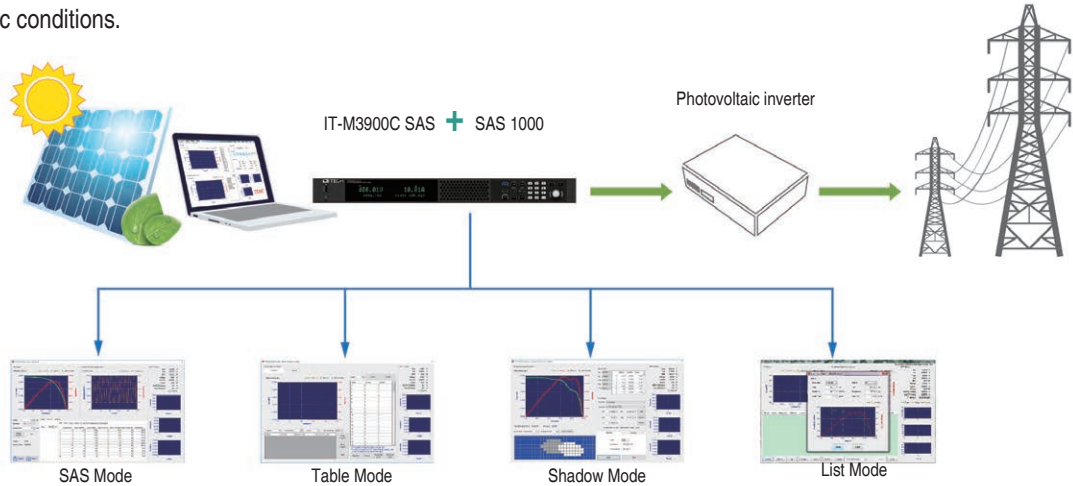

Built-in a variety of standard automotive test curves

Automotive electronics may often encounter power transients during vehicle start-up and operation. To ensure that the device under test can withstand these actual transients, the tester must simulate worst-case power transient conditions during the test. According to the relevant standards of the industry, IT-M3900C had not only built-in standard automotive voltage curve DIN40839, ISO-16750-2, SAEJ1113-11 LV124 and ISO21848, but also built-in LV123, LV148 and other standards for new energy vehicles testing. Users can directly retrieve from the panel to test the performance of relevant automotive electronics, without reprogramming or purchasing additional test software, saving effort and money compared to other competitive products.

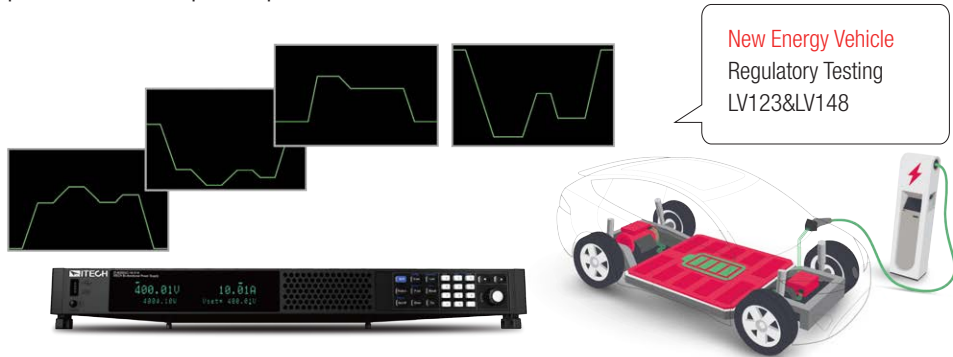

Charging/Discharging test

IT-M3900C series have unique bidirectional design, variable output impedance and CC / CV / CP / CR four operation modes under load mode, one unit IT-M3900C can simulate the charging and discharging characteristics of the battery and realize the setting of various test conditions and data processing of the battery. It is suitable for charging / discharging tests of various portable batteries.

ITS5300 Battery Test System the following test items can be realized: Working conditions simulation, Charge & discharge characteristic test, Battery cycle life test, Battery conformance test. Battery DCIR test, Battery temperature test, Battery capacity test, Battery pack endurance test, Reliability test, Battery overcharge/over discharge endurance test.

IT-M3900D High power DC power supply



IT-M3900 series integrates the features of a DC power supply, a bi-directional power supply, a source and load system, and a regenerative electronic load in one. It keeps the advantages of high power density and architecture design of M series, power up to 6kw, current up to 510A, and voltage up to 1500V within one 1U unit, effectively reducing the equipment occupation space and cabinet time. wide-range models could meet different test requirements while matching with multi-functional, high energy-saving, high-safety, and high-stability product design, let the customer be confident to face a variety of complex testing, improving the products competition ability.

Feature

- Compact design, power up to 6kW in 1U space, power up to 12kW in 2U space
- Voltage range: 10-1500V
- Current range: 8A~1020A
- Power range: 1700W~12kW
- Wide range of output design, one unit can be used as multiple power supplies
- With simple master/slave parallel connection, expand power while maintaining performance*1
- CC/CV priority
- Adjustable output impedance
- Built-in function generator, support arbitrary-waveform generating
- List function, up to 200 steps can be set
- Support multiple working modes, adjustable rise and fall time
- The front panel supports the insertion of USB storage devices to meet the import of List files/Export, data logging functions, etc.
- Standard build-in USB/CAN/LAN/digital IO communication interface, optional GPIB/analog & RS232

*1 If 1U models>16, 2U models>8, pls. contact ITECH.

The IT-M3900D series is a single channel output programmable DC power supply. The density structure design can effectively save rack space. Also with wide-range output design, can provide a wider range of voltage and current combinations within the specified power range. One unit can be used as multiple power supplies, more flexibility. The CC/CV priority allows user to switch the output mode according to the different needs of the DUT priority, match with the high-precision and high-speed product characteristics, and a variety of standard communication interfaces, simplifying and speeding up the test development, can meet users' variety testing application, widely used in laboratories, production lines, and automatic test systems.



	Model	Current	Power	Size
10V	IT-M3901D-10-170	170A	1700W	1U
	IT-M3903D-10-340	340A	3400W	1U
	IT-M3905D-10-510	510A	5100W	1U
	IT-M3910D-10-1020	1020A	10200W	2U
80V	IT-M3902D-80-40	40A	2kW	1U
	IT-M3904D-80-80	80A	4kW	1U
	IT-M3906D-80-120	120A	6kW	1U
	IT-M3912D-80-240	240A	12kW	2U
500V	IT-M3902D-500-12	12A	2kW	1U
	IT-M3904D-500-24	24A	4kW	1U
	IT-M3906D-500-36	36A	6kW	1U
	IT-M3912D-500-72	72A	12kW	2U
1500V	IT-M3906D-1500-12	12A	6kW	1U

	Model	Current	Power	Size
32V	IT-M3902D-32-80	80A	2kW	1U
	IT-M3904D-32-160	160A	4kW	1U
	IT-M3906D-32-240	240A	6kW	1U
	IT-M3912D-32-480	480A	12kW	2U
300V	IT-M3902D-300-20	20A	2kW	1U
	IT-M3904D-300-40	40A	4kW	1U
	IT-M3906D-300-60	60A	6kW	1U
	IT-M3912D-300-120	120A	12kW	2U
800V	IT-M3902D-800-8	8A	2kW	1U
	IT-M3904D-800-16	16A	4kW	1U
	IT-M3906D-800-24	24A	6kW	1U
	IT-M3912D-800-48	48A	12kW	2U

*This information is subject to change without notice.

Power Supply

Applications

Electrolytic plating

Water treatment, surface coating, plating

5G Communications & Data Centre

Server power supply, UPS inverter unit

Semiconductor field

Ion injection, MOCVD power supply

Industrial component

Fuses, automotive connector, current sensor

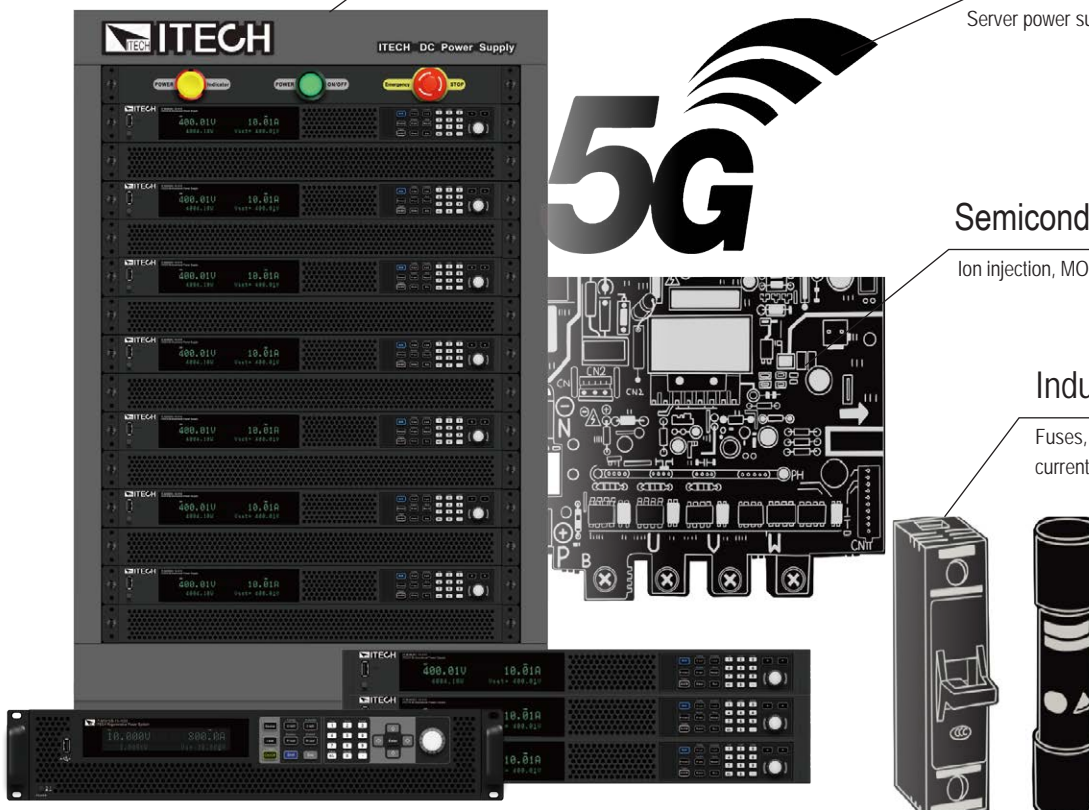

High power density, compact design

ITECH has always adhered to the design concept of high power density to help users optimize the test solutions. The IT-M3900D series adopts a compact structure design to effectively save rack space, and provide up to 6kW power output in a 1U chassis, up to 12kW power output in a 2U chassis, which makes the entire portfolio of ITECH high power density series more complete and comprehensive.



Reduced volume by 2/3



IT-3900D series

VS

Testing solution for 6kW



Other power supplies

Wide range output

There are 25 models included in IT-M3900D series. The output voltage ranges from 10V to 1500V and the maximum output current of a single unit can reach 1020A. The wide-range output design provides more voltage and current combinations than conventional fixed-range output DC power supplies, which is more flexible. Just a single unit can cover a wide range of applications which makes it easy to build power systems and largely save room for you at the same time.

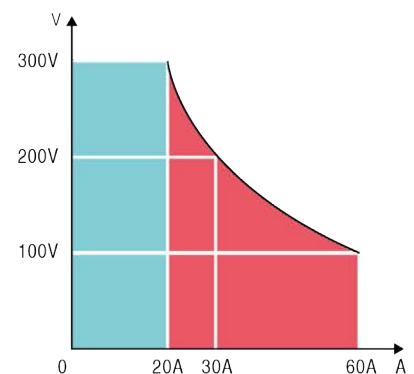
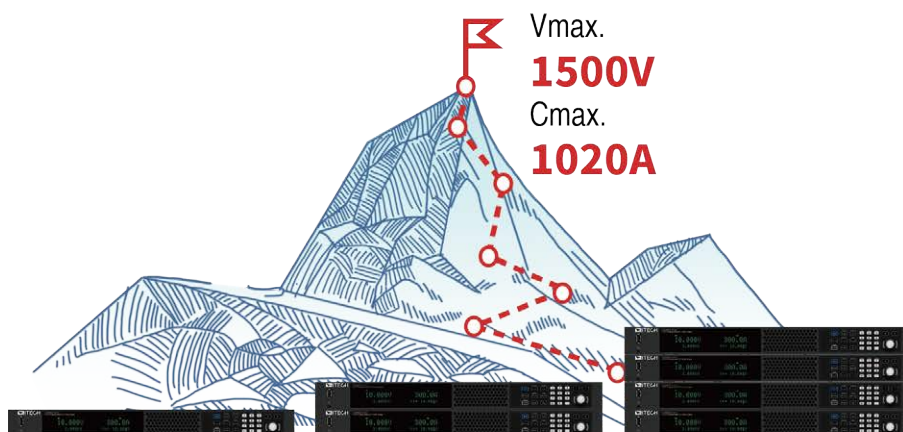

+ ITECH Operating range
Operating range of other 300V products on the market

CC&CV priority function

CC/CV priority can continue to help users solve various severe problems in long-term test applications to make applications that require high-speed power or non-overshoot more flexible. The CC&CV priority function of IT-M3900D allows the user to select the response speed and the loop working mode of the CC/CV loop to determine whether the output is high-speed voltage mode or non-overshoot current mode, which is suitable for high-power integrated circuit testing, charging and discharging testing, power transient simulation and characterization of automotive electronics, etc.

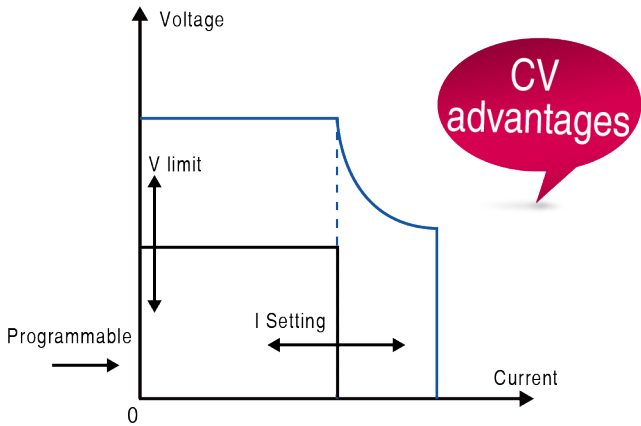

Start surge current over current range to build voltage at high speed (CV-High, CC-Low, CV advantages)

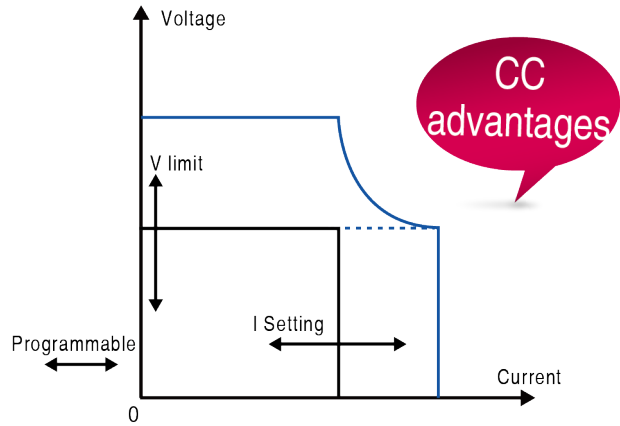

High-speed and seamless battery charging and discharging, no overshoot switching (CV-High, CC-High, CC advantages)

Application

Diode, laser diode, LED, power semiconductor component testing

When facing a diode load, users can easily set the CC priority mode test in the menu. Advantages: The conventional power supply defaults to the CV loop priority, Therefore, the speed of suppressing the current overshoot at the moment of starting is slower. The CC/CV priority allows users to adjust the loop speed according to test requirements, such as setting it in CC priority mode to avoid output overshoot.



Diode load
Conventional power test

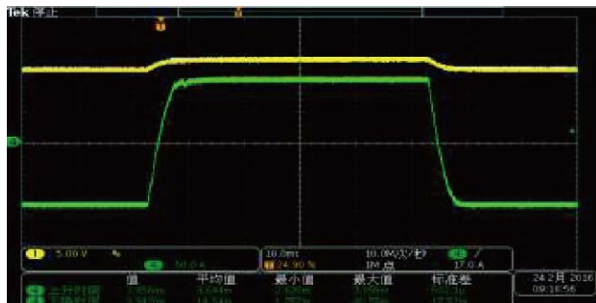

Diode load
IT-M3900D CC priority mode

High efficiency parallel connection technology

Considering the user's convenience and versatility, IT-M3900d can use master/slave control mode to parallel 6 units or more. Meanwhile ITECH fiber optic parallel technology fully solve the problems of slow speed and poor accuracy of traditional parallel methods. It is suitable for calibration and measurement, R&D lab, production line and ATE test.

The parameters will not change after parallel connection

Calibration is not requested after parallel connection

Optical fiber transfer between master and slave, guarantee perfect performance of anti-interference

Adopt Optical fiber isolation technology, effective protection of the device and DUT

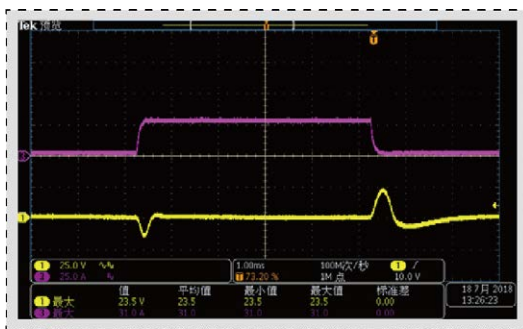

Single Unit

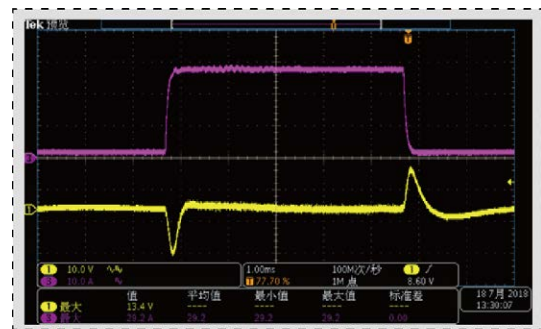

Parallel unit



Application

Electrolytic plating, Sewage treatment, Surface coating, Sputtering, Hydrogen production from electrolytic water

Recommendation: : IT-M3906D-32-240 *5 units in parallel

Advantages: ① low voltage high current output to meet the demand of ultra-high current test; ② small size high power density, 32V in 1U can reach 240A ③ High accuracy of current output, electroplating current can be arbitrarily configured according to requirements. The output is stable and reliable.

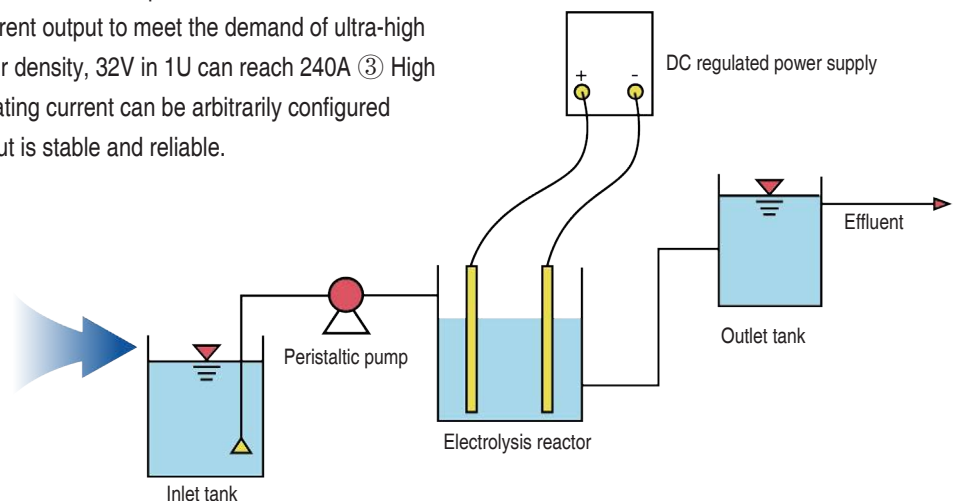

Multiple interfaces

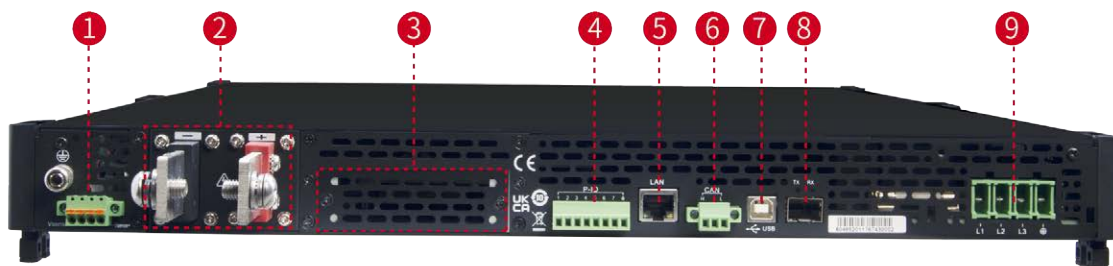

1 Sense terminals (Vs+, Vs-)

2 DC output terminals of the power supply

3 Interface for optional accessories

4 Digital I/O interface: P-IO

5 LAN Communication Interface

6 CAN Communication Interface

7 USB Communication Interface

8 Communication interface of outer ring optical fiber (TX and RX)

9 AC power input terminals (L1, L2, L3, and PE)

Optional Accessories

Category	Model	Specification	Description
Parallel kit	IT-E4029-15U	IT15U cabinet	800mm×550mm X907.6mm
	IT-E4029-27U	IT27U cabinet	800mm×600mm×1362.75mm
	IT-E4029-37U	IT27U cabinet	800mm×600mm×1764.35mm
	IT-E168	Optical fiber cable kit	Connection between the units in a cabinet
	IT-E155A/B/C	Cabinet rack mount Kit	Cabinet rack mount installation
Functional Module	IT-E165A-250 *1	Anti-reverse protection unit 750V/250A	avoid reverse connection
	IT-E165A-400 *1	Anti-reverse protection unit 750V/400A	avoid reverse connection
	IT-E165A-500 *1	Anti-reverse protection unit 900V/400A	avoid reverse connection
	IT-E165B *2	Anti electromotive force protection unit	avoid current back flow
Other accessories	IT-E258	5m power cord for 3U unit, CN standard	AC input power cord
	IT-E258-15U	5m power cord for 15U unit, CN standard	AC input power cord
	IT-E258-27U	5m power cord for 27U unit, CN standard	AC input power cord
	IT-E258-37U	5m power cord for 37U unit, CN standard	AC input power cord
	IT-E176	GPIB communication interface	
	IT-E177	RS232&analog communication card	

*1 The voltage/current of the DUT must be within the IT-E165A rated range

*2 The voltage/current of the DUT must be within the IT-E165B rated range

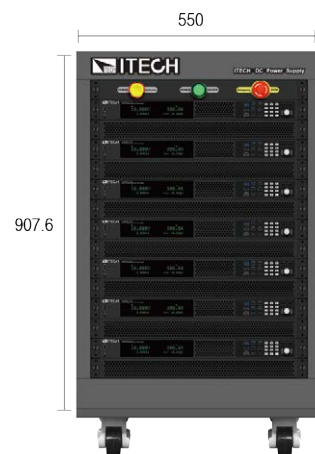

IT-E4029-15U (Dimension:mm)

Power Supply

IT-M3100 Series Ultra-compact Wide Range DC Power Supply



Feature

- 1U Half-Rack, Ultra-Compact Size
- Adjustable rising/falling speed of output current, to meet various test applications
- High speed test, up to 10 times per second
- Up to 100 steps LIST operation, support output of various dynamic waveforms
- Support CC/CV loop speed and priority setting
- Parallel operation can be easily controlled by one unit
- Independent control of multi-channels, one communication card can control up to 16 channels, max.256 channels
- Support output of different timings of each channel, can synchronize or delay the output, and supports the output of different ratios of voltage
- Support CANOPEN, LXI, SCPI and other communication protocols
- Five optional cards for plug-and-play function, providing RS232,CAN, LAN, GPIB, USB_TMC, USB_VCP, RS485, external analog and IO communication interfaces
- Support TRACE function, can draw voltage and current waveforms in real time (Supported by IT9000-PV3100)
- Battery charging test function
- Software watchdog provides more reliable and safe automatic battery test solution
- Various protection functions such as OVP, OCP, OPP, OTP, ensure secure testing
- Provide self-locking function, when the device is self-locked, the device will not be able to output

To meet increasing test demands from various industries, ITECH newly released IT-M3100 series is not only innovative in terms of product series is not only innovative in terms of product technology, but also from the perspective of industry application to provide complete innovative solutions. Breaking through the traditional tech limits, in the ultra compact size of only 1U Half-Rack, the unit can not only output high power, but also has high performance and versatility . It supports the master-slave parallel mode. The full range of models support multiple stacking and parallel connection by handily designing "leg" plug-in. Fit with rack mount kit to achieve the perfect use. This new series will empower the engineers with innovation and implement test technology advancements more quickly and more accurately. The IT-M3100 series consists of 12 models, providing 6 voltages grades, and can be combined to achieve a variety of output power. It has a flexible modular architecture, independent multi-channel design, and supports synchronous operation. Users can configure each channel according to the test requirements of DUT, up to max. 16*16 channels, to meet the needs of customized solutions. It has a wide range of application such as research and development, design verification and automatic test systems intergration.

Ultra-compact - Only 1/2 1U

IT-M3100 series power supply is only 1/2 1U. But its maximum output power is up to 850W. It has not only high power density, but also has high precision and resolution and reliable stability. The maximum output voltage is up to 600V and maximum output current is up to 100A. Since the output voltage and current are restricted by limited power, lower current can get higher voltage and lower voltage can get higher current. One unit can be used in various applications.

	Model	Voltage	Current	Power
20V	IT-M3110	20V	100A	400W
	IT-M3120	20V	100A	850W
	IT-M3130	20V	120A	1500W

	Model	Voltage	Current	Power
30V	IT-M3111	30V	70A	400W
	IT-M3121	30V	70A	850W
	IT-M3131	30V	120A	1500W

	Model	Voltage	Current	Power
80V	IT-M3112	80V	22A	400W
	IT-M3122	80V	22A	850W
	IT-M3132	80V	40A	1500W

	Model	Voltage	Current	Power
150V	IT-M3113	150V	12A	400W
	IT-M3123	150V	12A	850W
	IT-M3133	150V	20A	1500W

	Model	Voltage	Current	Power
300V	IT-M3114	300V	6A	400W
	IT-M3124	300V	6A	850W
	IT-M3134	300V	10A	1500W

	Model	Voltage	Current	Power
600V	IT-M3115	600V	3A	400W
	IT-M3125	600V	3A	850W
	IT-M3135	600V	5A	1500W

Parallel operation can be easily controlled by one unit

IT-M3100 is extensible. Users can have different current by units parallel connection. For parallel connection, the maximum units quantity is up to 4.

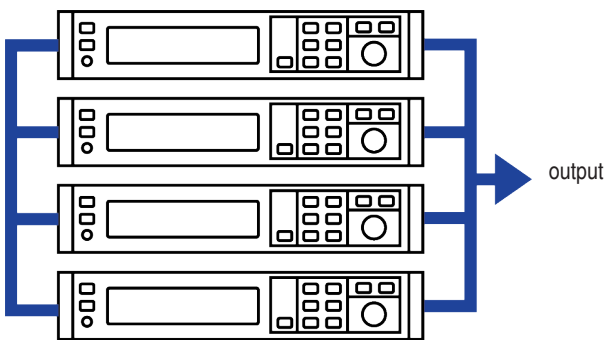

4 units IT-M3120 parallel connection

Synchronism (Link)

IT-M3100 has the function of synchronism between multiple channels. There are 3 options On/Off, Track, Duplicate. The synchronism works for On/Off, Save/Recall, Priority mode, rising or falling of voltage and current value setting and function of Protect. And the voltage change can be proportional between different units.

CC&CV Priority

IT-M3100 series keep the function of CC/CV priority. It can make the test easier especially for the applications like high speed power supply or no overshooting current. Users can get fast voltage rising time by CV priority mode. This is helpful in the high speed voltage test. Users can also choose CC priority mode to output no overshooting current. It's good for test DUT under CC working condition. This is used in various application field such as laser test, IC test, charge and discharge test, transient simulation of power supply in automotive electronics and so on.

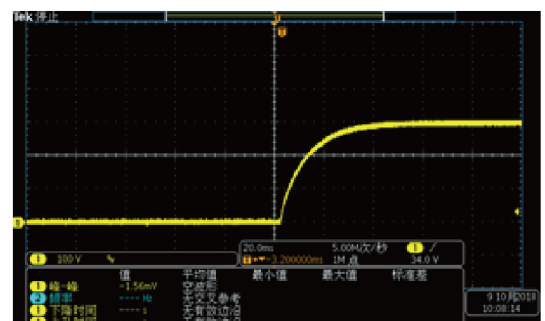

CV priority, voltage without overshoot

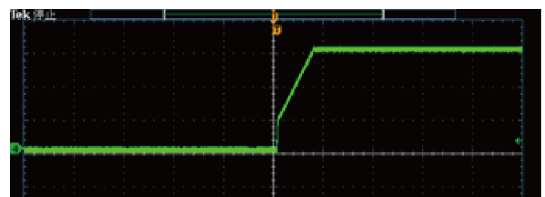

CC priority, current without overshoot

Multi-channel independent control, maximum 256 channels

IT-M3100 Series is provided with independent multi-channel design. The channel sequence will be displayed when 16 units IT-M3100 combines to be a multi-channel power system. The user can control each unit independently by PC software when connecting the communication interface of one unit with PC. Each channel can be operated separately.

IT-M3100 supports maximum 16*16 channels. One 37U rack case contains 64 channels. The user may test DUTs with different power ranges by parallel connection, making tests more flexible and device usage more efficient.

* Please contact ITECH for the specific multi-channel solution

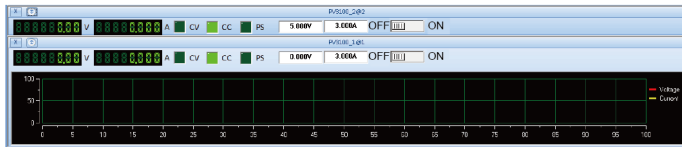

IT-M3100 multi-channel power supplies are widely used in production testing, multi-channel load aging system, integrated circuits etc. fields.

Application 1

When the product is powered by DC and need to do aging test by many channels, similar to DC-DC converter, the charge part of battery aging test, and circuit board etc., the multi-channel power supply is a must, to ensure the synchronization and output consistency. Meanwhile, the program command is much simpler for system test. The user needs to send many commands to control each power supply with traditional multiple units of power supplies. By using M3100, the user only need to synchronize multiple units, and send one command to control the master unit only.

Application 2

Nowadays, the development of integrated circuits tends to be miniaturized. Most of the AC input voltage requires multiple power supplies to realize. Normally a high-voltage main input and multiple voltage auxiliary inputs are required. The multi-channel power supply is needed to do AC input test. If adopts the traditional multiple power supply to multi-path mode physically, it will cause asynchronous control, and result in the circuit board not working. The M31 series adopts the synchronous trigger output function to ensure the synchronization of the output, effectively solve this problem.

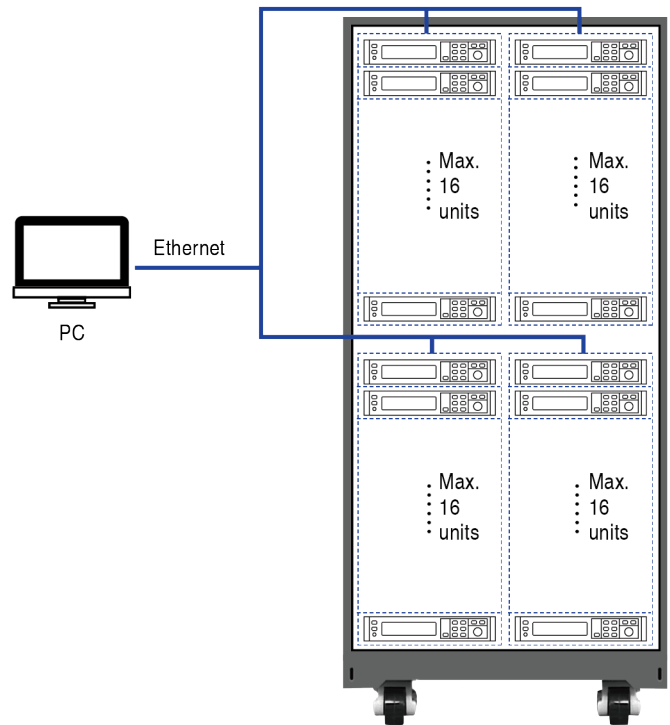

Modular design, flexible combination

IT-M3100 breaks through the shackles of traditional product design, with a side ventilation design. The flexible modular design makes it simple for IT-M3100 to stack directly, no need to purchase any accessories. The open structure brings users with different free combinations, just like blocks stacking, simple and convenient.



* Stack up to 10 units without rack mount kit

Battery Charging function

IT-M3100 series can test batteries with its battery charging function. The users can set different parameters as turn off conditions: voltage, current, capacity and charging time. When any of the above parameters meet the set condition, it will shut off the test automatically. During the process, the users can observe the voltage, charging time and capacity. Additionally, IT-M3100 can be operated with software, which to achieve reliable auto-test solution.

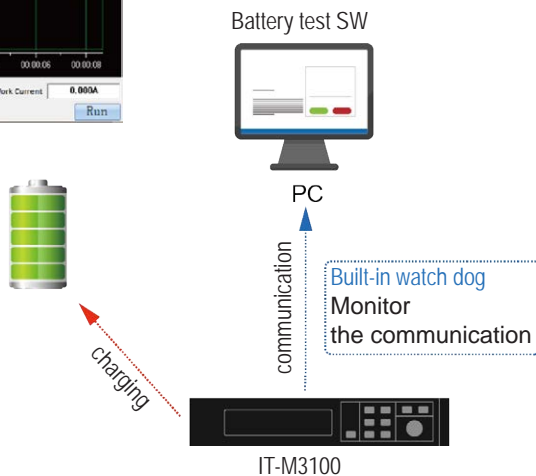
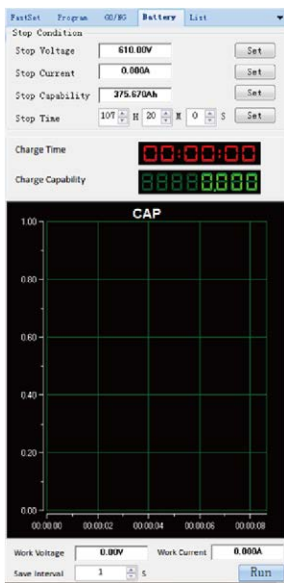
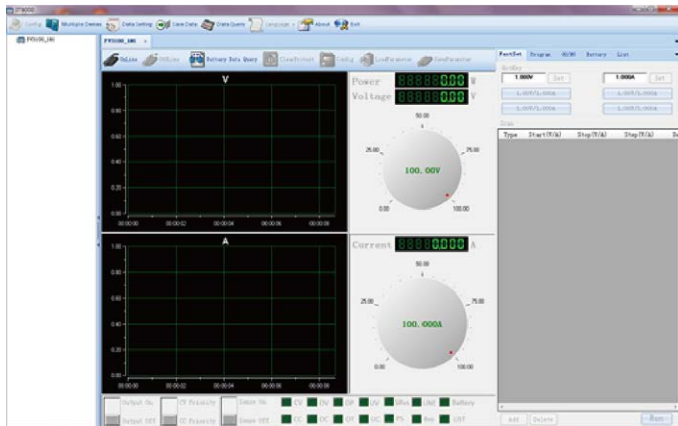

Battery Charging function

IT-M3100 series adopts high density design with 1U half-rack space. Users may put 2-3 units on bench for initial tests at low power with less channels. When they need more power or more channels, it is convenient to use IT-E154 to gather one or multiple units IT-M3100 to install into the rack case. It is flexible for the customers to configure based on specific requirements to avoid waste.

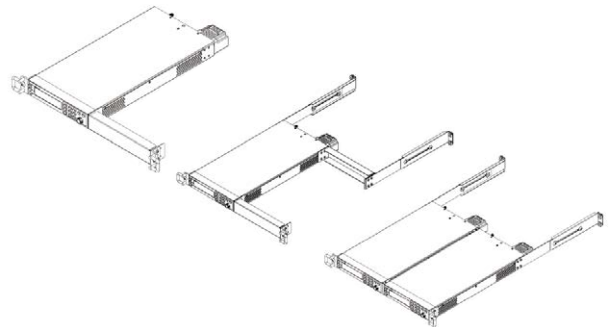

Optional accessory

IT-M3100 series rear panel provide below listed optional extension interfaces for users to choose. Optional rack mount kit is also available.

Pictures	Model	Interface
	IT-E1205	GPIB Interface
	IT-E1206	USB/LAN Interface
	IT-E1207	RS-232/CAN Analogue interface
	IT-E1208	/RS485 Interface
	IT-E1209	USB Interface



Standard rear panel



Rear panel with optional interface

IT-M3100D Dual-channel DC Power Supply



IT-M3100D dual-channel programmable DC power supply, only 1U half rack, provides fully isolated dual-channel output. The automatic wide-range design can provide you with higher voltage and current output, so one unit can cover a wide range of applications. Its flexible modular design, independent multi-channel design and simultaneous operation function allow you to configure each channel freely. IT-3100D dual-channel programmable DC power supply is especially suitable for production line aging test and building automated test system. At the same time, it can also be widely used in experiments and evaluation, quality management and so on.

Feature

- High power density, 1U Half-Rack only Isolated dual-channel design
- Different timing output of each channel, synchronous or delayed output, output with different voltage ratios
- Adjustable rise/fall time
- Up to 100 steps LIST operation, support output of various dynamic waveforms
- CC/CV loop speed and priority setting
- Independent control of multi- channels, one communication card can control up to 16 channels
- Series/parallel connection between two channels is available ***1 new**
- Support CW
- Support CANOPEN, LXI, SCPI
- Five optional cards , providing RS232, CAN, LAN, GPIB,USB_TMC, USB_VCP, RS485, external analog and IO communication interfaces
- Support TRACE function, can draw voltage and current waveforms in real time (Supported by program)
- Various protection functions such as Sense, OVP, OCP, OPP, OTP, Foldback
- Provide self-locking function, when the device is self-locked, the device will not be able to output

*1 Max.100V can be output after series/parallel connection

Model	CH1	CH2
IT-M3131D	30V/15A/200W	30V/15A/200W
IT-M3141D	30V/15A/400W	30V/15A/400W
IT-M3132D	60V/10A/200W	60V/10A/200W
IT-M3142D	60V/10A/400W	60V/10A/400W



Ultra-compacted - Only 1U Half-Rack

IT-M3100D dual-channel DC power supply is only 1U half rack, but it can output 400W per channel. In addition to high power density, it also features as high resolution, high precision and stability. The automatic wide-range design brings more combinations of voltages and currents, which means that one unit can cover a variety of testing requirement.



Modular design, flexible combination

Thanks to the modular design, several units of IT-M3100D dual-channel DC power supply can be freely stacked, no additional accessories needed, as easy as building blocks.

* Max.10 units can be stacked without rack mount kit.

Of course, you can also use the IT-E154 rack mount kit to easily install one or more units in a standard 19-inch rack. Flexible combination can effectively help you to avoid repeated purchases of equipment.



Multi-channel independent control

The IT-M3100D dual-channel DC power supply adopts an independent multi-channel design, which makes it easy to connect between the power supply and the computer. When a multi-channel power supply system is formed, the channel number will be displayed on the interface of each power supply. If the communication interface of one of the units is connected to the computer, you can independently control each power supply in the system by software. Each channel can be operated independently. A 37U cabinet can include up to 40 units/80 channels, which greatly increases the utilization rate of the equipment.

* For details, pls. contact ITECH.

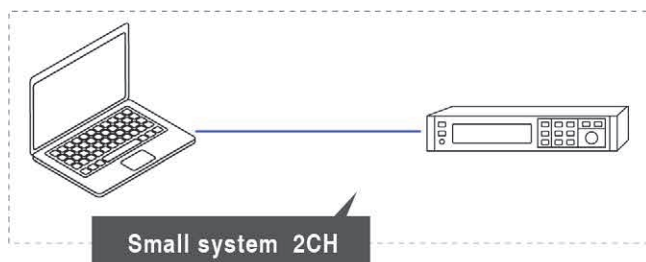

Small system 2CH

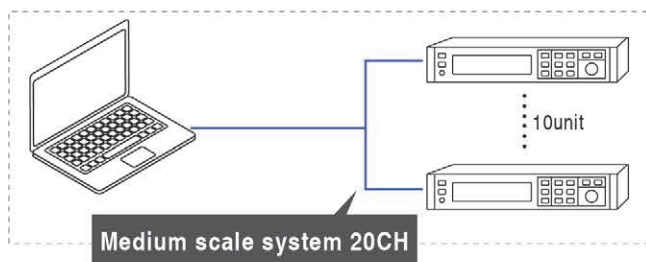

Medium scale system 20CH

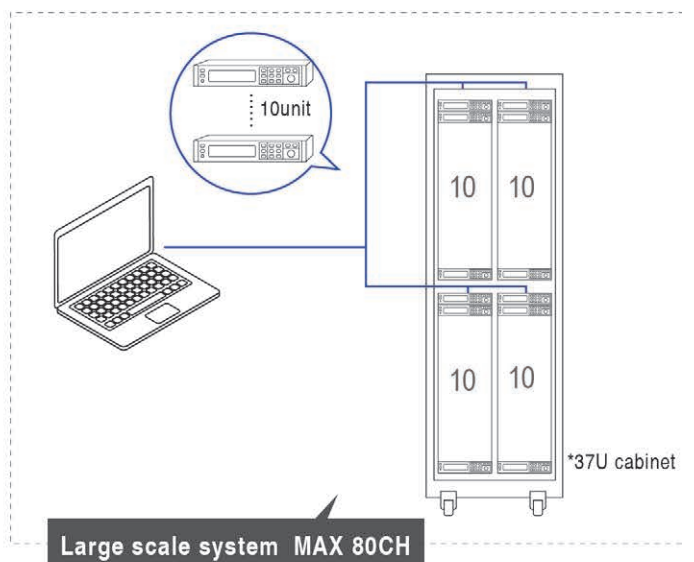

Large scale system MAX 80CH

*37U cabinet

Synchronism (Link)

IT-M3100D supports synchronization function whether it is a single unit or in a multi-channel power supply system. It is suitable for the simultaneous testing of multiple DUTs, or the application scenarios where the DUT is multi-channel power input. There are three synchronization modes for you, On/Off, Track, Duplicate. You just need to configure parameters on one power supply, and the parameters can be automatically replicated or synced proportionally to other power supplies in the loop.

When the ON/OFF function is used with the ON/OFF delay function in the menu, synchronous power-on or sequential power-on can be realized.

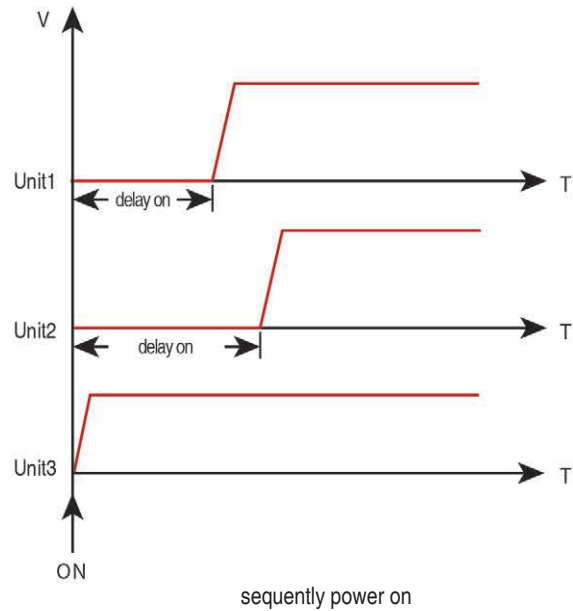
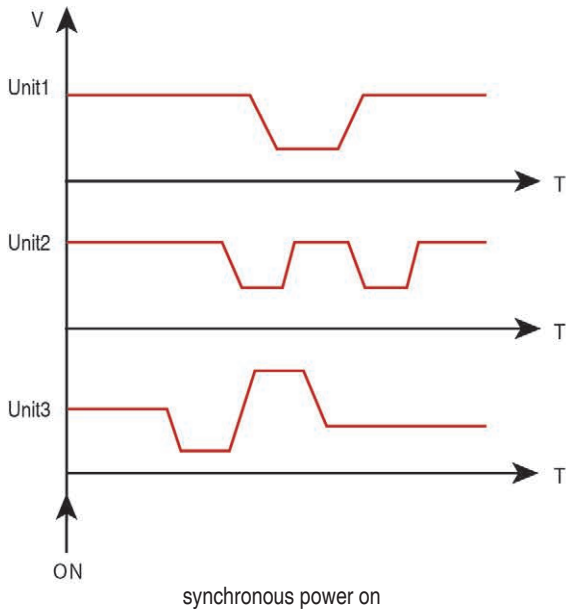

Multi-Protection Function

IT-M3100D dual-channel DC power supply has various protection functions such as OCP / OVP / OTP / OPP / U-Max/U-Min/Sense/ Foldback. The Sense function helps to pop up a warning in time and switch the power supply to the Local output when the output terminal fails. The Foldback function is used to turn off the output when the power CV / CC is switched, so as to protect DUT that are sensitive to voltage overshoot and current overshoot.





CC & CV priority function

The CC / CV priority function helps to solve a variety of severe problems in long-term testing. For test that require high-speed voltage or no overshoot, you can select the CV priority mode to obtain a faster voltage rising speed. Or you can choose CC priority mode to output current without overshoot, which is used to test DUTs with constant current operating characteristics. This function is good for laser testing, IC testing, charge and discharge testing, power transient simulation and characterization of automotive electronics, etc.

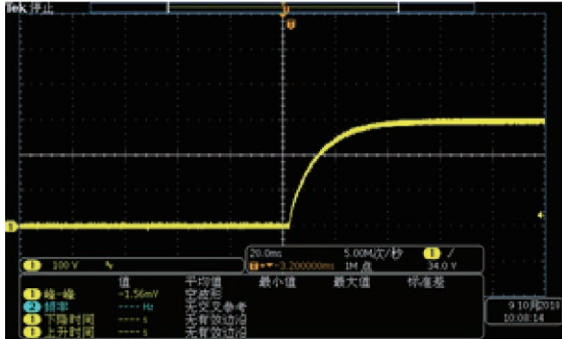

CV

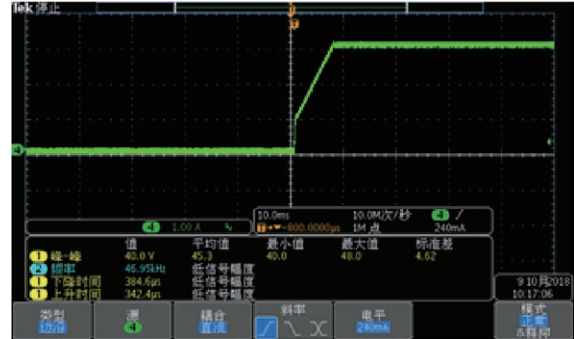

CC

Web server access

IT-M3100D has a built-in Web server. You can monitor and control it through your web browser. After the IT-M3100D and the computer are connected via LAN interface, enter the IP address of the power supply in the browser, and then you can access the front panel control functions including the LAN configuration parameters.

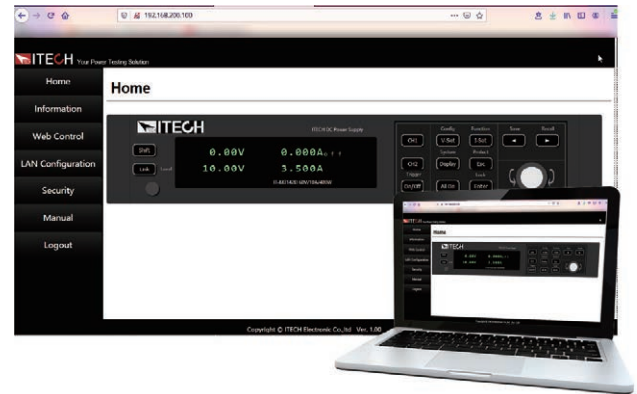

Optional accessory

The rear panel of the IT-M3100D series provides interface expansion slots. You can choose different interfaces to achieve different functions, such as communication interfaces, external analog interfaces and rack mount kit.

Pictures	Model	Interface
	IT-E1205	GPIB Interface
	IT-E1206	USB/LAN Interface
	IT-E1207	RS-232/CAN Interface
	IT-E1208	Analogue interface /RS485 Interface
	IT-E1209	USB Interface

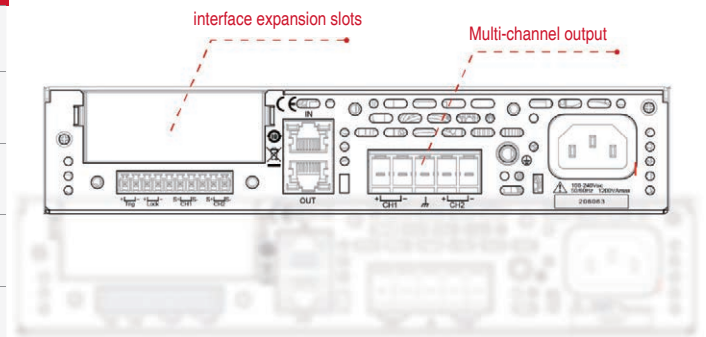

IT-M3200 High-precision Programmable DC power supply



IT-M3200 high-precision programmable DC power supply adopts a mixed modes design, which not only takes into account high power and low ripple output, but also has dynamic load response, switching between multiple current measurement ranges. It meets various current measurement requirement from ampere level to micro-ampere level.

IT-M3200 has a flexible modular architecture, independent multi-channel design with synchronous operation function. Users can configure each channel arbitrarily according to the test requirements of the DUT. The maximum channels is up to 16*16 which can meet various customized test requirements. It is widely used in the test fields of 3C products, semiconductor devices, 5G, IoT and medical electronic equipment, etc.

Feature

- 1U Half-rack, maximum power is up to 360W
- Wide range measurement
- Low ripple and noise
- High resolution, high accuracy and high stability
- Current readback is up to 10nA
- Four current measurement ranges Low/Middle/High/Auto
- CC/CV priority setting
- Foldback
- Adjustable rise/fall time, soft start / stop
- Multi-channel independent control, one communication card can control 16 channels, up to 256 channels
- Different timing output of each channel to achieve synchronization or proportional tracking List
- Support multiple communication protocol,CANOPEN,LXI,SCPI
- Five optional cards, supporting RS232,CAN,LAN,GPIB, USB_TMC,USB_VCP,RS485, analog and IO
- Multiple protection, OVP/OCP/OTP/OPP/UVP/UCP

Model	Voltage	Current	Power
IT-M3223	60V	10A	100W
IT-M3233	60V	10A	200W
IT-M3243	60V	10A	360W
IT-M3253	20V	20A	100W
IT-M3263	20V	20A	200W
IT-M3273	20V	20A	360W





Application Fields

Smart sensor module testing

Acceleration sensor, gyroscope test, flow sensor, pressure sensor test, etc.

5G test

GSM module, WiFi module, optical module test, etc.

Power semiconductor discrete device testing

IGBT chip test, power management chip, LED / OLED display power consumption test, etc.

Wearable device testing

Medical wearable devices, smart bracelet testing, etc.



1U half rack Mini size

IT-M3200 provides 360W power output with 1U half rack size. Besides of the high-power density, it has high resolution, high accuracy and multi-range measurement functions. With auto-ranging design, the device covers a wide range of application requirements.



Modular design, flexible combination

The unique plug-in design makes it as simple as building blocks to stack IT-M3200 devices, without purchasing any additional accessories. Meanwhile, users can choose optional IT-E154 rack mount kit to install one or more units into a standard 19-inch cabinet easily.

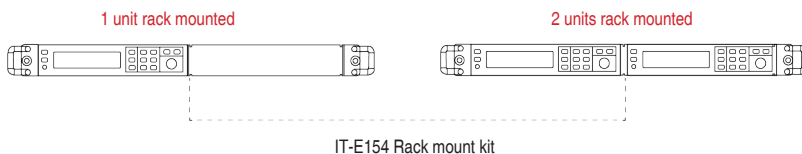

Multi-level current range

IT-M3200 provides multi-level (Low/Middle/High/Auto) current range switching, with resolution up to 10nA, to meet the current measurement needs from Amp level to micro-amp level. The user can realize the flexible switching between low and high current measurement at the Auto level, no need to control manually. This function is suitable for testing in the fields of 5G, wearable devices and other low power consumption products.

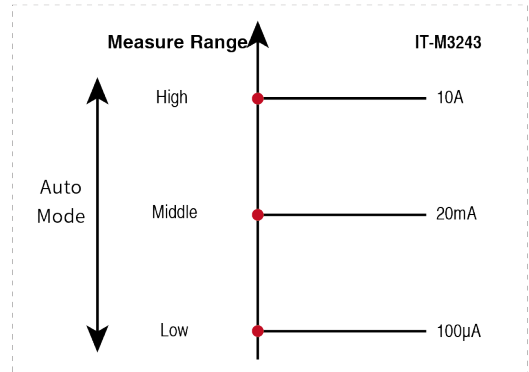

Multiple channel independent control

IT-M3200 Series is provided with independent multi-channel design to simplify the complex wiring between device and PC. When the communication interface of 1 unit IT-M3200 of a multi-channel system is connected with PC, we may realize remote control of 16*16 channels at maximum.

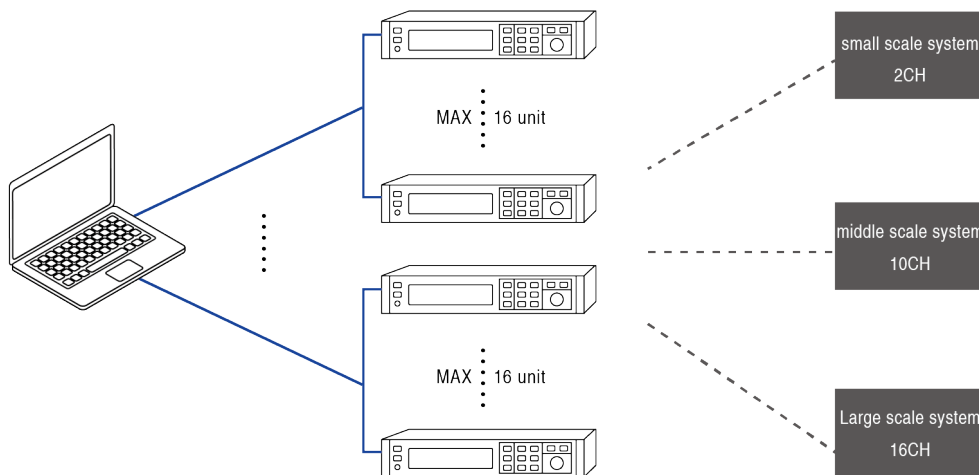

CC & CV Priority

IT-M3200 series have CC/CV priority function, which helps the user to solve the problems, and make the tests easier especially for the applications of high speed power supply or no overshooting current. Users can get fast voltage rising time by CV priority mode. This is helpful in the high-speed voltage test. Users can also choose CC priority mode to output no overshooting current. It's good for test DUT under CC working condition. This is used in various application fields such as laser test, IC test, charge and discharge test, transient simulation of power supply in automotive electronics and so on.

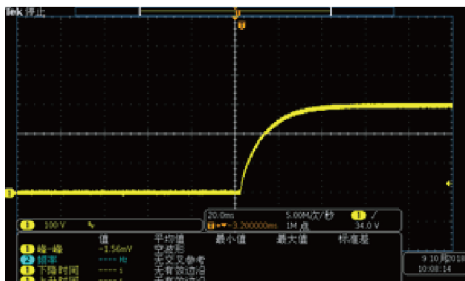

CV priority, voltage without overshoot

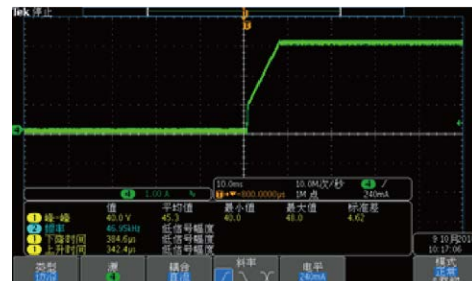

CC priority, current without overshoot



Soft start/ stop function

IT-M3200 Series can be set the rise up and fall time of output voltage or current to prevent the sudden up and down of voltage at the moment of onloading or unloading, triggering the DUT false protection action.

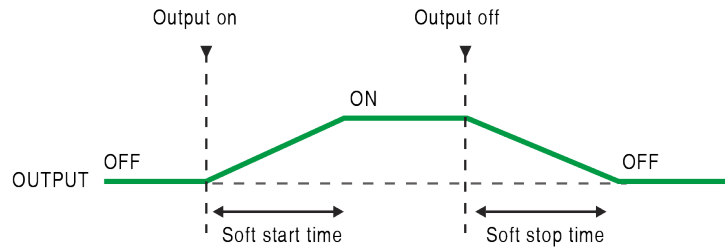

Foldback protection

IT-M3200 Series with Foldback protection function, is used for turn off the output when the power supply is switched by CV/CC, so as to protect certain DUT that are sensitive to voltage overshoot and current overshoot. User can specify working mode and set the delay time protection, if the current working mode is switched, it will trigger the protection and turn off the output when the delay time is used up.

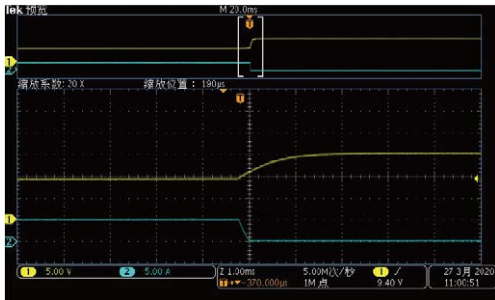

CC to CV, no overshoot

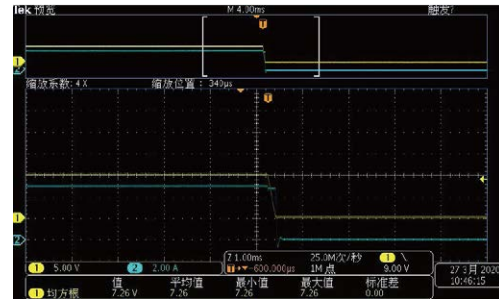

CV to CC, no overshoot

List Function

Users can modify and edit the output waveform of the voltage and current with time according to customer's test requirements without use the software, also can control the voltage rise and decline slope. the power supply will automatically transform the output according to pre-edited waveform after receiving the trigger signal.

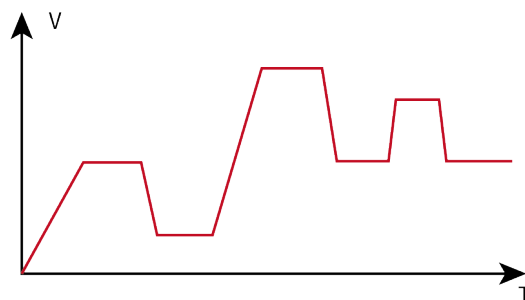

Link function

The Link function is mainly designed for the cascade control of multiple devices. It is especially suitable for the multiple DUT synchronized testing or the application of multi-channel power input. IT-M3200 series support Duplicate / On-Off / Track of three modes, user only need to set the parameters on one of the power supplies, then automatically copy the set parameters or proportionally synchronize to other devices of M3200 series in the cascade circuit.

IT-M3200 series may performance two solutions of synchronous power-on and in sequence power-on When the link-on / off function is used with the on / off delay function in the menu.

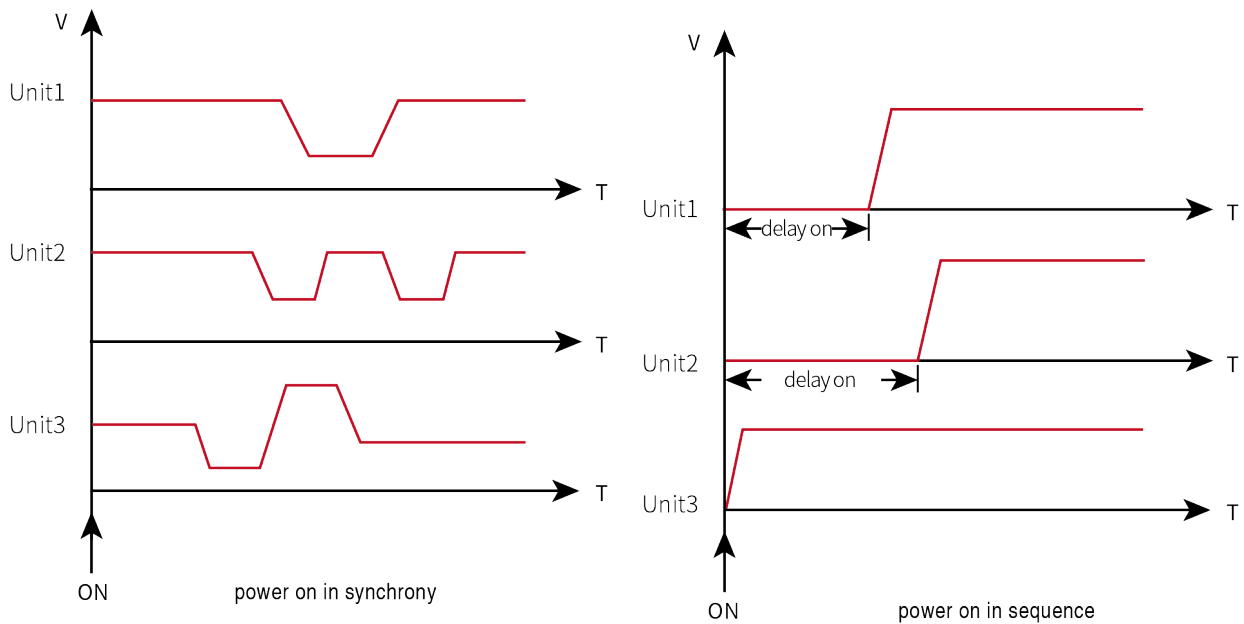

Optional accessories

IT-M3200 series provides below optional multiple interfaces on rear panel to realize different functions, like communication interface, external analog interface.

Pictures	Model	Interface
	IT-E1205	GPIB Interface
	IT-E1206	USB/LAN Interface
	IT-E1207	RS-232/CAN Interface
	IT-E1208	Analogu interface /RS485 Interface
	IT-E1209	USB Interface
	IT-E154A/B/C	Rackmount Kits



Standard rear panel

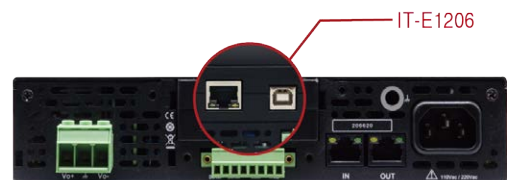

Rear panel with optional interface

IT-M3400 Bidirectional DC Power Supply

Bidirectional

High efficient power regeneration

Battery simulation/charge and discharge test

Independent control of multiple channels



Power Supply

IT-M3400 bidirectional DC power supply integrates the features of a bidirectional power supply and a regenerative load. It keeps the advantages of high power density and modular architecture design of M series.

It can meet the customer's test requirement of different current and power level. Thanks to the independent multi-channel design, users can configure each channel according to the quantity and specifications of the DUT. At the same time, it has high-precision output and measurement, and has made a number of safety designs for testing, suitable for multiple test fields, such as power modules, intelligent industrial equipment, automotive electronics, charging and discharging tests of various small-capacity batteries.

Feature

- 1U Half-rack, high power density
- Bidirectional energy flow*
- High efficient power regeneration
- Battery test
- Battery simulation
- Independent control of multi-channels with functions of synchronization and proportional tracking
- High speed measurement, 10 times/S updating rate
- CC/CV priority
- Adjustable output impedance
- Programmable voltage and current rise and fall time
- Temperature measurement function, over temperature protection
- List
- Various protection such as OCP / UCP / OVP / OTP / OPP / UVP over heat protection, grid fault protection and fault storage, foldback, Power-off protection, sense abnormal protection
- Automatic detection of power grid state to realize reliable grid connection
- Pre charge function to prevent overshoot of DC loading current
- Anti-reverse protection function through optional accessories
- Five optional cards, supporting RS232,CAN,LAN,GPIB,USB_TMC,USB_VCP, RS485, analog and IO interface

*Only support sink current under CC mode after been paralleled

Model	Voltage	Current	Power	Model	Voltage	Current	Power
IT-M3412	60V	30A	200W	IT-M3414	300V	6A	200W
IT-M3422	60V	30A	400W	IT-M3424	300V	6A	400W
IT-M3432	60V	30A	800W	IT-M3434	300V	6A	800W
IT-M3413	150V	12A	200W	IT-M3415	600V	3A	200W
IT-M3423	150V	12A	400W	IT-M3425	600V	3A	400W
IT-M3433	150V	12A	800W	IT-M3435	600V	3A	800W

Seamless switching between source and sink

Different from the traditional power supply and load, when positive and negative current switch, there will be a short jump and Incoherence. IT-M3400 integrates bidirectional power supply and regenerative e-load in one, which is capable of achieving high-speed and seamless switching between source and sink. In this way, a fast and seamless switch between source and sink effectively avoids voltage or current overshoot, which is widely used in batteries, battery packaging, battery protection boards and other energy storage equipment testing.

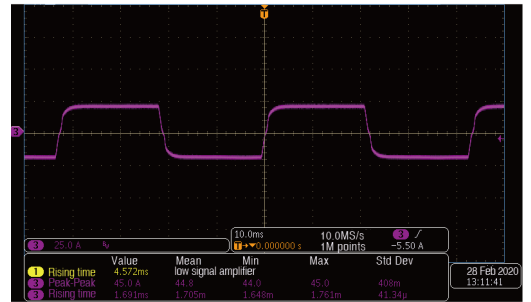

CC priority charge and discharge seamless switching

1U Half-rack mini size

IT-M3400 is 1U Half-rack mini size and support output up to 800W, not only with high power density, but also with high resolution, high precision and high stability. The output voltage can reach 600V and the output current can reach 30A. There are 12 models in the whole series, with a wide range of output design, and one unit can cover a wide range of applications.



Applications

Low-power power module test

DC-DC power module test, micro-inverter
DC-AC test, bidirectional DC-DC module test

Intelligent industrial equipment testing

UAV ESC test, small robot servo motor test

Various small capacity battery charge and discharge test

Electric vehicle battery, 3C product battery,
UAV battery

Automotive electronic equipment power supply test

Electric power steering motor, electric brake
ibooster



CC & CV priority function

IT-M3400 continues to support CC / CV priority function, help customers solve a variety of severe problems in long-term testing. For test that require high-speed voltage, users can select the CV priority mode to obtain a faster voltage climb speed; or choose CC priority mode, output current without overshoot, used to test DUT with constant current operating characteristics. This function is widely used in power supply transient simulation and characterization test applications, such as lasers, integrated circuits, charge and discharge, automotive electronics.

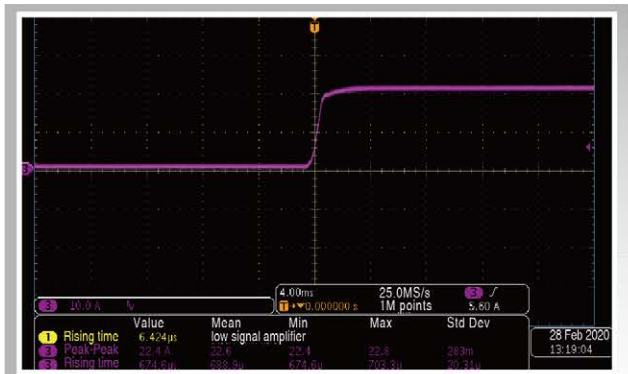

CC priority

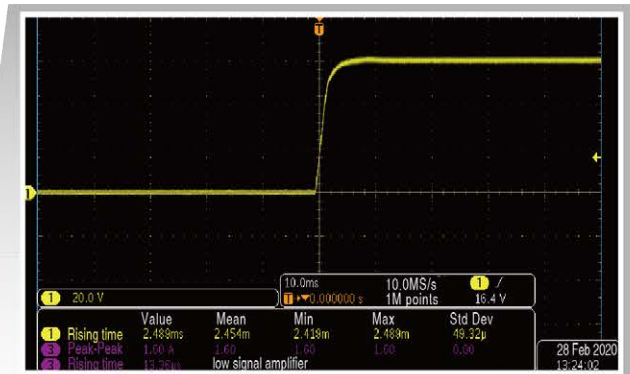

CV priority



Module architecture, any combination

IT-M3400's modular plug-in architecture can easily stack instruments like building blocks without any additional accessories. Besides that, users can choose IT-E154 rack installation kit, easily install one or more instruments in a standard 19-inch cabinet.

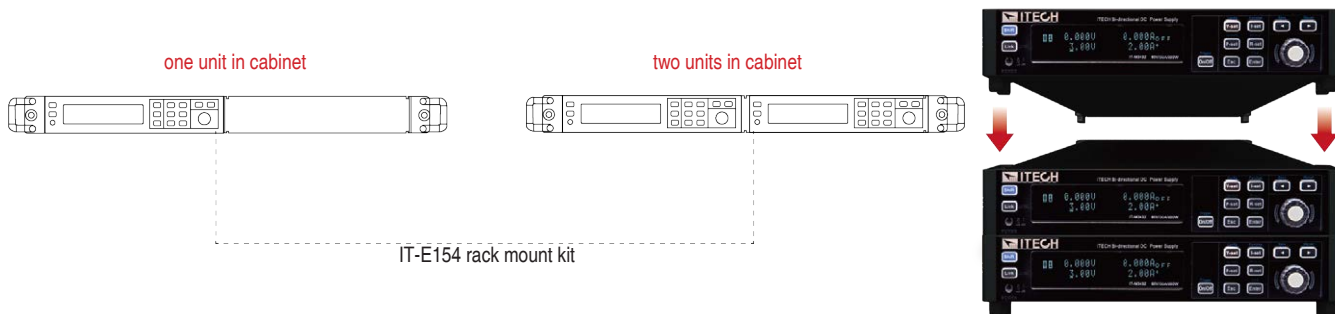

Multi-channel independent control, up to 256 channel

IT-M3400 provides flexible multi-channel function, the users can build-up multi-channel source-sink system, each unit will show the channel number on the front panel. PC only need to connect with one unit to control and program all the units independently by GUI software.

IT-M3400 support maximum 16*16 channels, each 37U rack can integrate 64 units which is 64 channels.

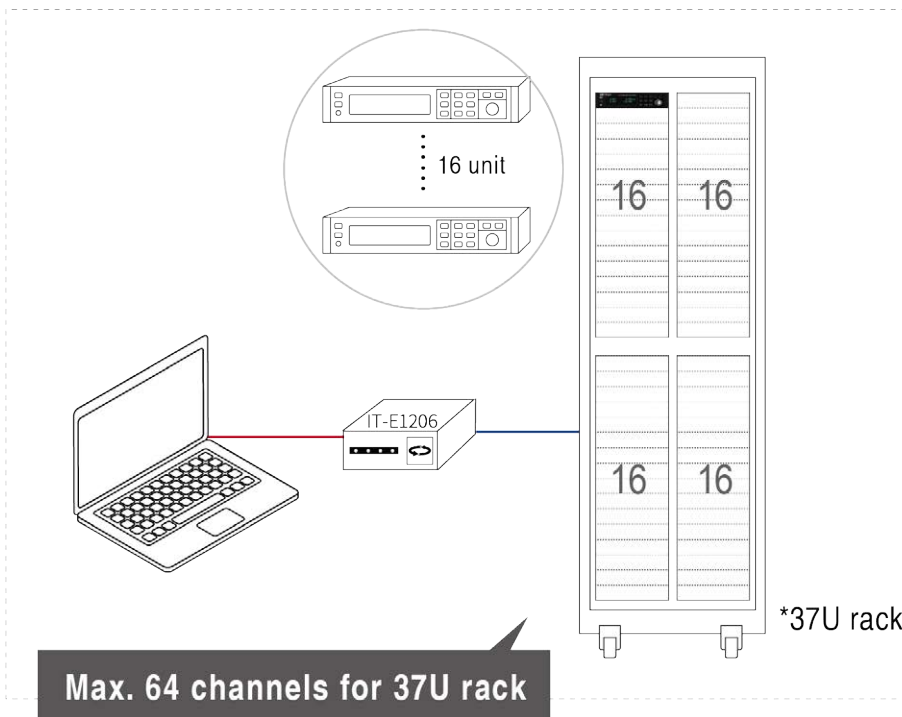
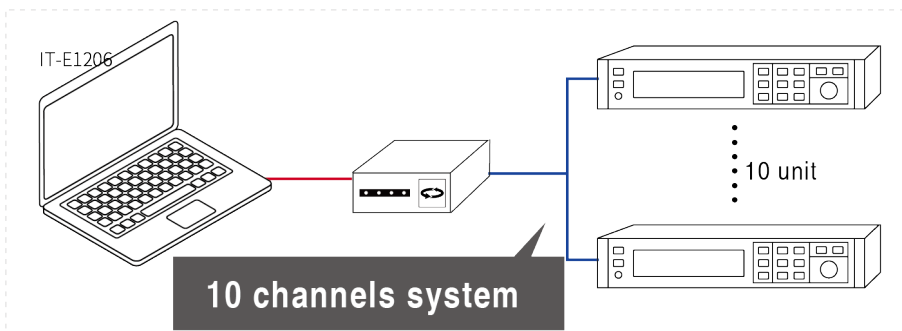
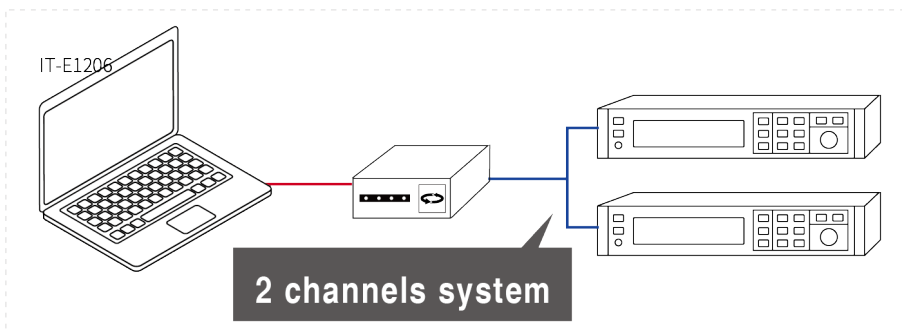

High energy regeneration efficiency

IT-M3400 supports energy regeneration function, the efficiency is up to 90%, which save cost both for the electricity and cooling system, create low noise testing environment.

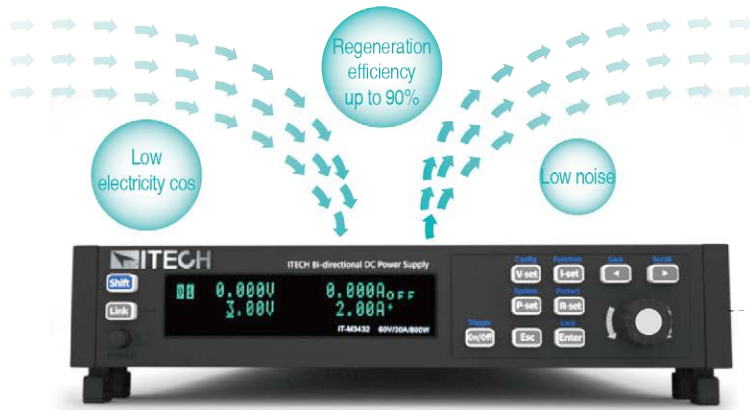

≈ 6307kW·h
can be deducted from your electricity bill using 1pc IT-M3400(800W) for 1 year

Power Supply

Battery simulation function

IT-M3400 can simulate up to 99 batteries in series and parallel. The user can set the battery voltage, capacity, internal resistance, and SOC to quickly define the battery matrix.

The user can set the battery by choosing ITECH optional professional BSS2000 battery simulation software, by setting common battery parameters to quickly establish the battery characteristic curve, they can also set the initial capacity of the battery, to verify the characteristics of the product in different states of the battery. At the same time, BSS2000 supports user to import matlab battery matrix or import the actual battery charge and discharge curve through .CSV file, to simulate real battery's charge and discharge characteristics.

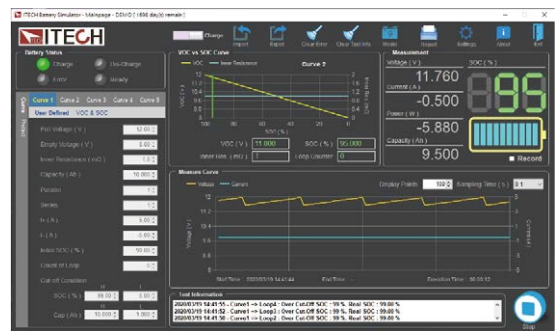

BSS2000 battery emulation software interface

*Please contact ITECH for further details.

Battery Test Function

IT-M3400 series Regenerative Power System, which integrates power supply and regenerative electronic load one unit, and adjustable output impedance design, can simulate the charging and discharging characteristics of the battery, and perform other testing, too. It can be used not only test the multiple single cells, but also comprehensive test the battery packages. It can also perform the battery setting and data processing in various test conditions and plot the test figure.

Optional ITS5300 professional battery test software can perform the following test items:

- working condition simulation
- Battery DC IR Test
- Battery endurance test
- Battery Temperature Test
- Reliability Test
- Charge and Discharge characteristic
- Battery cycle life test
- Battery capacity test
- Over charge and Over discharge endurance test
- Battery conformity test

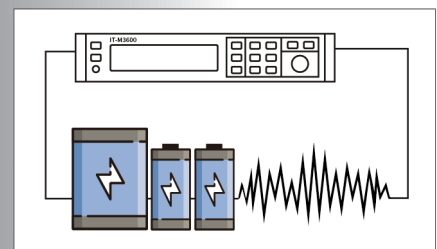

Multi-Protection Function

IT-M3400 have various protection functions such as OCP / UCP / OVP / OTP / OPP / UVP, power grid fault protection and fault storage functions, as well as power-off protection and Sense sensing abnormal protection.

The unique Foldback protection function is used to turn off the output when the power CV / CC is switched, so as to protect DUT that are sensitive to voltage overshoot and current overshoot.

The automatic detection function of power grid state will shut down the product in case of sudden disconnection of power grid connection, which can realize reliable grid connection function and islanding protection function.

Precharge function can prevent DC loaded current from overshoot. Users can choose anti reverse connection module to realize anti reverse connection protection function to effectively suppress battery surge.



Optional Accessories

IT-M3400 rear panel provides interface expansion slot for users to expand. Different interfaces can be selected to realize different functions, such as communication interface, external analog interface, temperature sensor, etc.

Pictures	Model	Interface
	IT-E1205	GPB interface
	IT-E1206	USB/LAN interface
	IT-E1207	RS-232/CAN interface
	IT-E1208	External analog/RS485 interface

Pictures	Model	Interface
	IT-E1209	USB interface
	IT-E118	Anti-reverse connection module
	IT-E1203	Temperature sensor
	IT-E154A/B/C	Rack mount kit



Standard Rear Panel



Rear Panel with optional interface

IT-M3600 Regenerative Power System

One button switch between source and load

High efficient power regeneration

Battery simulation and test

PV inverter I-V curve simulation



Power Supply

IT-M3600 regenerative power system integrates two instruments in one device, composed by a bidirectional power supply and a regenerative electronic load. When being used as a load, its energy recovery function can convert the absorbed DC power into AC power and return it to the local grid. When being used as a power supply, it is a wide range bidirectional DC power supply. IT-M3600 combines the advantages of both instruments well, and its small size of only 1U half rack also help to save your space, time and cost. IT-M3600, with high-precision output and measurement, it is suitable for multiple test fields such as multi-module batteries, multi-channel power supplies, micro inverters, and semiconductor devices.

Feature

- 1U half rack, high power density
- One button switch between source and load
- Bidirectional energy flow between DUT and grid
- High efficient power regeneration
- Battery test
- Battery simulation
- 8 operating modes: CC/CV/CP/CR/CV+CC/CC+CR/CV+CR/
CV+CC+CP+CR*1
- Independent control of multi-channels, implement synchronization or proportional tracking
- High-speed measurement, keep 10 times / s update rate even connecting 16 stand-alone units
- CC/CV priority
- PV inverter I-V curve simulation*2
- Adjustable output impedance
- Programmable rise/fall time for voltage and current*3
- Temperature measurement function, over temperature protection
- List
- Various protection such as OCP, UCP, OVP, OTP, OPP, UCP, over heat protection, grid fault protection and fault storage, foldback, Power-off protection, sense abnormal protection
- Automatic detection of power grid state to realize reliable grid connection
- Precharge function to prevent overshoot of DC loading current
- Anti-reverse protection function through optional accessories
- Five optional cards, supporting RS232, CAN, LAN, GPIB, USB_TMC, USB_VCP, RS485, analog and IO communication

*1 Multiple operation modes is only available under load function *2 Stay tuned

*3 Only current rise and fall time can be set under load function

Model	Voltage	Current	Power	Model	Voltage	Current	Power
IT-M3612	60V	30A	200W	IT-M3614	300V	6A	200W
IT-M3622	60V	30A	400W	IT-M3624	300V	6A	400W
IT-M3632	60V	30A	800W	IT-M3634	300V	6A	800W
IT-M3613	150V	12A	200W	IT-M3615	600V	3A	200W
IT-M3623	150V	12A	400W	IT-M3625	600V	3A	400W
IT-M3633	150V	12A	800W	IT-M3635	600V	3A	800W

Applications

Various small capacity battery charge and discharge tests

Electric bicycles, balance bikes, drone batteries, sweeping robot batteries, etc

Battery simulator, simulate the IV curve of different characteristics battery

Servo motor test, unmanned electromechanical test, smart meter test, etc.

Low Power Module Test

Bidirectional DC-DC module test, small inverter module test

Semiconductor IC, relay, wiring harness and other aging test

Power regulator, intelligent electronic switch IPS, auto central control box aging test

Test in photovoltaic field, simulate IV curve of small photovoltaic array

Micro inverter, photovoltaic IC test, photovoltaic optimizer test



One button switch between source and load

IT-M3600 integrates two devices in a small size of 1U Half-rack, which can not only be operated as a high-performance bidirectional DC power supply; but also be operated as a regenerative e-load. Simulate various load characteristics and feedback power to grid without pollution, multi-functions in one. Users do not need to use software and any terminal equipment to switch operation mode, one button switching can greatly save time and space

1U Half-rack

IT-M3600 is only 1U Half-rack, but the power output is up to 800W. Besides high power density, it also has high resolution, high accuracy and high stability, etc. The output voltage is up to 600V and the output current is up to 30A. All series containing 12 models with ultra-wide range output design, can be widely used in various Applications.



Seamless switching between source and sink

Different from the traditional power supply and load, the switch between positive and negative current, it will have transient jumps and discontinuities. IT-M3600 integrate bidirectional power supply and regenerative load in one unit. When work under source mode, it supports high speed switch between source and sink mode, such seamless switch between positive and negative current is fast, continuous, and seamless, so as to avoid the current or voltage overshoot during the test. This can be widely used to various tests related to storage unit such as battery, battery packaging, battery protection board etc.

*Only available for single unit.

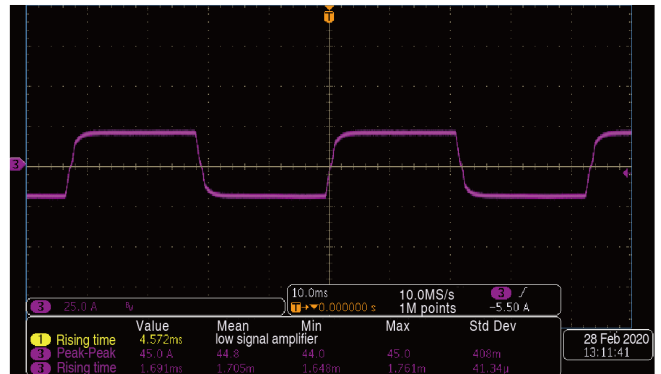

Seamless charging and discharging switch under CC priority

High energy regeneration efficiency

IT-M3600 series is regenerative when working in sink under source mode, also regenerative working under load mode. The max regeneration efficiency is up to 90%, which can save the cost for both electricity and cooling system, achieving low noise testing environment.

≈ 6307kW·h can be deducted from your electricity bill using 1pc. IT-M3600(800W)



Battery simulation function

IT-M3600 support to simulate max. 99 cells in series and parallel connection. The users can quickly select battery matrix by setting battery voltage, capacity, resistance, SOC from the front panel.

ITECH provides optional BSS2000 battery simulation software, users can self-define the battery curve by setting common parameters, also can set battery initial capacity to verify the DUT characteristics under different battery status. Meanwhile, BSS2000 supports to import matlab battery matrix or CSV. file with battery charging and discharging curve, so as to simulate real battery charge and discharge characteristics.

*Please contact ITECH for details.

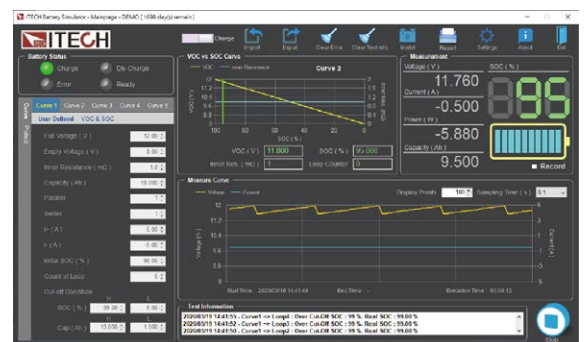

BSS2000 battery simulation software interface

Solar panel I-V curve simulation

IT-M3600 configured with optional ITECH SAS1000 Solar Array Simulation Software, users can accurately simulate the I-V curve. Built-in EN50530、Sandia、NB/T32004、CGC/GF004、CGC/GF035 standard testing procedures, it is convenient for users to test the static and dynamic MPPT performance of PV inverters and generate reports. Solar simulation power supply also provides the shadow and table mode operation, the user can enter up to 1024 points array to edit any shielded IV curve to achieve dynamic shadow effect simulation and also can store 100 I-V curves under different irradiation and temperature to test the long-term maximum power tracking performance of photovoltaic inverters under different climatic conditions.

Battery Test Function

IT-M3600 series Regenerative Power System, which integrates power supply and regenerative electronic load into one unit, and adjustable output impedance design, can simulate the charging and discharging characteristics of the battery, and perform other testing, too. It can be used not only test the multiple single cells, but also comprehensive test the battery packages. It can also perform the battery setting and data processing in various test conditions and plot the test figure.

Optional ITS5300 professional battery test software can perform the following test items:

- working condition simulation
- Battery DC IR Test
- Battery endurance test
- Battery Temperature Test
- Reliability Test
- Charge and Discharge characteristic
- Battery cycle life test
- Battery capacity test
- Over charge and Over discharge endurance test
- Battery conformity test

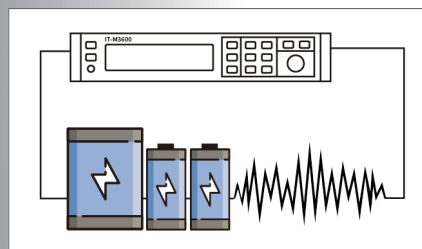

Multi-channel independent control, maximum 256 channels

IT-M3600 Series is provided with independent multi-channel design. The channel sequence will be displayed when it combines to be a multi-channel power and electronic load system. The user can control each unit independently by PC software when connecting the communication interface of one unit with PC. Each channel can be operated separately.

IT-M3600 Series supports maximum 16*16 channels. One 37U rack case contains 64 channels.

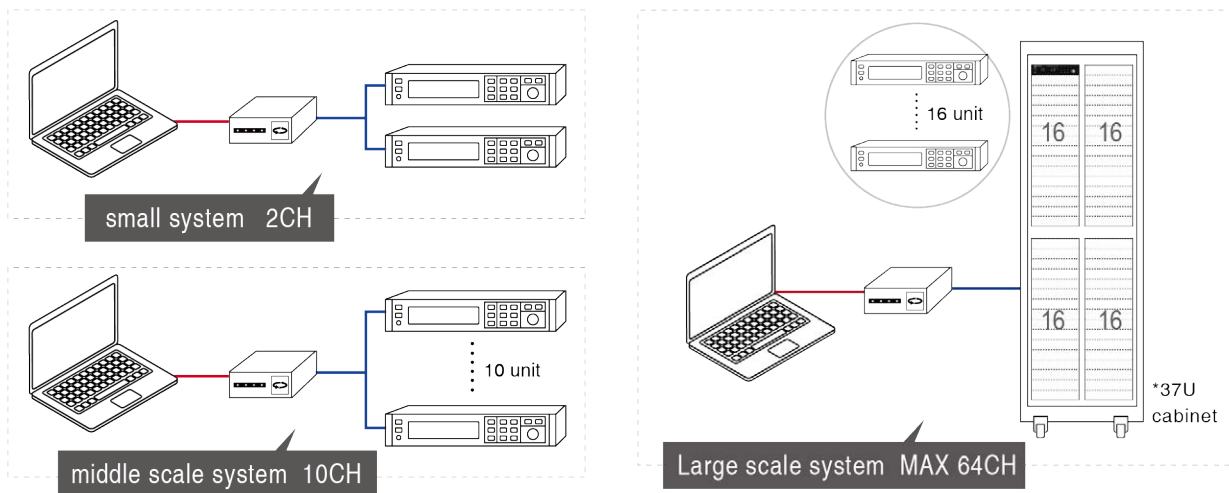

Multiple Protection function

IT-M3600 series have comprehensive protection functions, it can also provide OCP, UCP, OVP, OTP, OPP, UCP and grid fault protection, fault storage function, power-off protection function and sense sensing abnormal protection. With unique foldback protection function designing, it is used to turn off the output as soon as the power supply is switched by CV/ CC for protect the DUT which are sensitive to voltage overshoot and current overshoot. As it can automatic detect of power grid status, the product will be shut down when the power grid is suddenly disconnected, which can achieve reliable grid connection and islanding protection. The pre-charging function can prevent the DC load current from overshooting. Users can choose the anti-reverse connection module to achieve the anti-reverse protection function and effectively suppress the battery surge.

Multiple operation modes

IT-M3600 provide CC/CV/CP/CR basic operation modes based on power system mode.

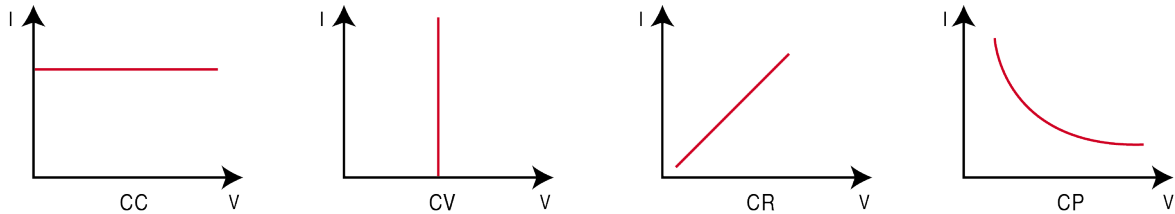

IT-M3600 also provide CC+CR/CV+CR/CV+CC/CC+CV+CP+CR four complex operation modes based on load mode, which can adapt to the test requirements of various occasions.



CC+CR mode can be applied to OBC feature test of voltage limit, feature test of current limit, constant voltage accuracy test, constant current accuracy test, to prevent over current protection.

CV+CR mode can be applied to simulate LED light, test LED power, LED current ripple parameters.



CV+CC mode can be applied to load simulate battery, test charging station or car charger, the maximum loading current is limited, when the CV is working.

CV+CC+CP+CR mode can be applied to test lithium-ion battery charger, to gain complete V-I charging curve. In addition, when protection circuit of DUT is damaged, it can auto switch to avoid damage.

CC&CV priority

IT-M3600 series continue the notion of CC&CV priority, help user to solve several critical problems with long-term testing. It can make the test easier especially for the applications like high speed power supply or no overshooting current. When need the testing occasions of voltage high speed, users can choose CV priority mode to get fast voltage rising time. Users can also choose CC priority mode to output no overshooting current, it's good for test DUT under CC working condition. This is used in various applications field such as laser test, IC test, charge and discharge test, transient simulation of power supply in automotive electronics and so on.

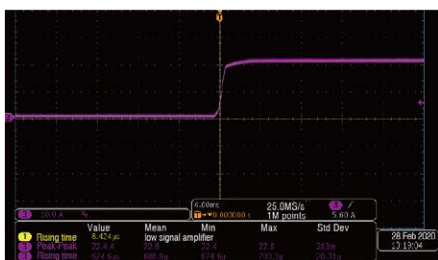

CC priority

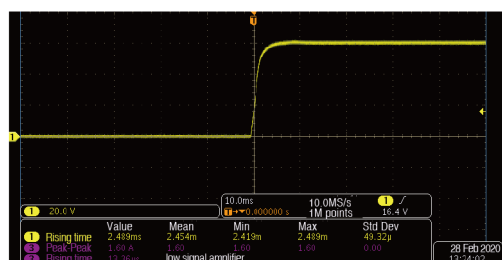

CV priority

Modular design, flexible combination

The flexible modular design makes it simple for IT-M3600 to stack directly, no need to purchase any accessories. The user may use IT-E154 optional rack mount kit to install one unit or more units into 19" rack case.

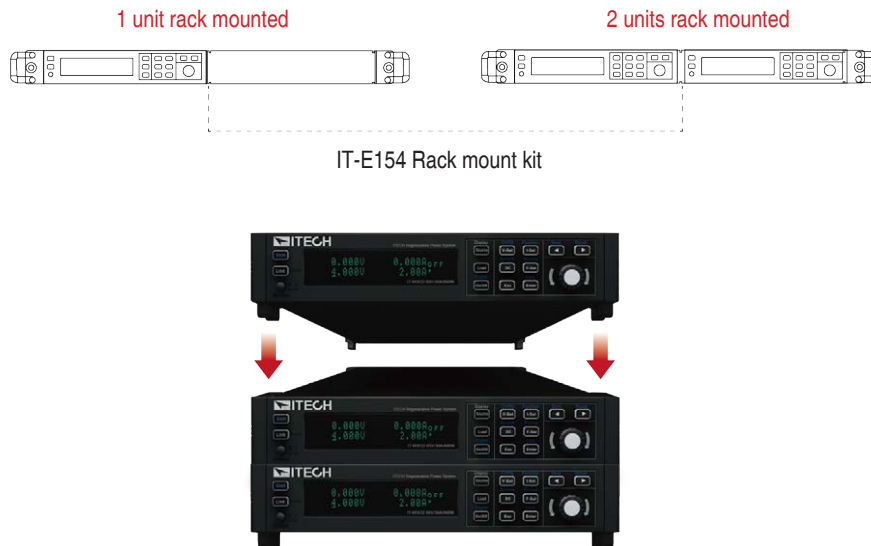

Optional accessories

IT-M3600 series provides below optional multiple interfaces on rear panel to realize different functions, like communication interface, external analog interface.

Pictures	Model	Interface
	IT-E1205	GPB
	IT-E1206	USB/LAN
	IT-E1207	RS-232/CAN
	IT-E1208	Analog
	IT-E1209	USB
	IT-E118	Anti-reverse module
	IT-E1203	Temperature Sensor
	IT-E154A/B/C	Rack mount kit



Standard rear panel



Rear panel with optional interface



IT6000B Series Regenerative Power System



Applications

Solar charger, Inverte, Power battery, Automotive motors, LED, UPS, Electric generator

Feature

- 2 in 1 device integrating bidirectional DC power supply and electronics load supported by advanced SiC technology
- One button switch between source and sink on panel
- Stand-alone power up to 144kW, expandable in parallel up to 2MW
- Voltage output ratings: 0-2250V
- Current output ratings: 0-2040A (single cabinet); 0-8000A (after parallel connection)
- High power density design provides 18kW in 3U space
- Bi-directional energy transmission, seamless switching across two quadrants
- Support CC/CV loop speed and priority setting
- Built-in voltage curves complying with automotive standards such as DIN40839, ISO-16750-2, ISO21848, SAEJ1113-11, LV124
- High efficient energy recovery
- Battery cycle test - support CC/CV/CP
- Built-in waveform generator, support generating arbitrary waveforms
- PV simulator(with SAS1000) - solar array I-V curves simulation
- Complete protection, support OVP, \pm OCP, \pm OPP, OTP, voltage transient drop protection and anti-islanding protection
- Built-in USB/CAN/LAN/digital IO interface, Optional GPIB/Analog&RS232
- Support data saving and the shortest interval of sampling is 10 μ s
- Battery simulator(with BSS2000) -Characteristic simulation of various batteries
- Strong dynamic driving profile simulation function, up to 10,000,000 points

From the perspective of improving customer experience, ITECH launches a new incorporated product--IT6000B series. Adopting advanced SiC technology, IT6000B integrates bidirectional power supply and regenerative electronic load into one 3U unit. It is also a very powerful one. Only a button is needed to switch between the bidirectional power supply and the regenerative electronic load. It can be used not only as a stand-alone powerful bidirectional power supply, as a source to provide power; but also as an independent regenerative electronic load, to absorb the consumed energy and feedback cleanly to the grid. IT6000B offers standard two-quadrants functionality.

IT6000B provides 7 voltage ranges, up to 2250V, supports master-slave parallel with current distribution up to 2000kW. Built-in waveform generator supports generating arbitrary waveforms, and imports LIST files for waveforms via USB interface. IT6000B is the combination of reliability, high efficient setting, safe and multiple measurement functions. IT6000B is a family of bi-directional, regenerative power system with excellent performance, extensively used in aspects of high power battery, automotive electronics, green energy, high speed testing etc.

One button switch between source and load

IT6000B innovatively incorporates two devices in one: a bidirectional power supply and a regenerative electronic load. The devices offer the functional button on panel for easy two-quadrants operation, either as a bidirectional programmable DC power supply or as a DC electronic load with recovery function. It reduces the space, cost and efforts on DUT for separate units.



Application

Power Supply

01 Renewable Energy		Solar Charger		Micro Inverter	Battery Pack	PV Inverter
02 Automotive	Automotive Motors		Car Charger	Automotive Electronics		Bidirectional DC/DC Converter
03 High-speed testing	Telecom	Power semiconductor components	High speed electronic test		LED products	Civil aviation
04 High-power testing		UPS	Electric motor/generator	Consumer products	Electro plating/welding	ATE systems

Specification

	Model	Current	Power		Model	Current	Power		Model	Current	Power
80V	IT6005B-80-150	150A	5kW	300V	IT6006B-300-75	75A	6kW	500V	IT6006B-500-40	40A	6kW
	IT6010B-80-300	300A	10kW		IT6012B-300-150	150A	12kW		IT6012B-500-80	80A	12kW
	IT6015B-80-450	450A	15kW		IT6018B-300-225	225A	18kW		IT6018B-500-120	120A	18kW
	IT6030B-80-900	900A	30kW		IT6036B-300-450	450A	36kW		IT6036B-500-240	240A	36kW
	IT6045B-80-1350	1350A	45kW		IT6054B-300-675	675A	54kW		IT6054B-500-360	360A	54kW
	IT6060B-80-1800	1800A	60kW		IT6072B-300-900	900A	72kW		IT6072B-500-480	480A	72kW
	IT6075B-80-2040	2040A	75kW		IT6090B-300-1125	1125A	90kW		IT6090B-500-600	600A	90kW
	IT6090B-80-2040	2040A	90kW		IT6108B-300-1350	1350A	108kW		IT6108B-500-720	720A	108kW
	IT6105B-80-2040	2040A	105kW		IT6126B-300-1575	1575A	126kW		IT6126B-500-840	840A	126kW
	IT6120B-80-2040	2040A	120kW		IT6144B-300-1800	1800A	144kW		IT6144B-500-960	960A	144kW

	Model	Current	Power		Model	Current	Power		Model	Current	Power
800V	IT6006B-800-25	25A	6kW	1500V	IT6018B-1500-40	40A	18kW	2250V	IT6018B-2250-25	25A	18kW
	IT6012B-800-50	50A	12kW		IT6036B-1500-80	80A	36kW		IT6036B-2250-50	50A	36kW
	IT6018B-800-75	75A	18kW		IT6054B-1500-120	120A	54kW		IT6054B-2250-75	75A	54kW
	IT6036B-800-150	150A	36kW		IT6072B-1500-160	160A	72kW		IT6072B-2250-100	100A	72kW
	IT6054B-800-225	225A	54kW		IT6090B-1500-200	200A	90kW		IT6090B-2250-125	125A	90kW
	IT6072B-800-300	300A	72kW		IT6108B-1500-240	240A	108kW		IT6108B-2250-150	150A	108kW
	IT6090B-800-375	375A	90kW		IT6126B-1500-280	280A	126kW		IT6126B-2250-175	175A	126kW
	IT6108B-800-450	450A	108kW		IT6144B-1500-320	320A	144kW		IT6144B-2250-200	200A	144kW
	IT6126B-800-525	525A	126kW								
	IT6144B-800-600	600A	144kW								

* This information is subject to change without notice



Bi-directional energy, seamless switching

The IT6000B Series combines bi-directional power supply and regenerative load function in one. Unlike traditional power supplies and E-loads, for which there will be short transitions and discontinuity in the middle of positive and negative current switching, IT6000B is a standard high-speed bidirectional power supply. It can switch seamlessly between source and sink mode fast and continuously, which avoids voltage or current overshoot effectively. It is widely used for testing energy storage devices such as batteries, battery packages, electric drives, etc.

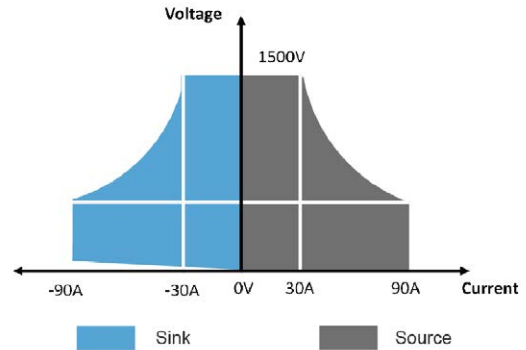

High energy regenerative efficiency

The IT6000B series has a unique function of energy regenerative that can regenerate electrical energy and then directly use it in the plant instead of consuming it in the form of heat. Its regeneration efficiency can reach up to 95%, which not only greatly reduces the user's electricity cost, but also avoids the use of air conditioning or expensive cooling systems. Most of the conventional electronic loads are energy-consuming loads. In addition to the high cost of electricity, large amounts of carbon dioxide, sulfur dioxide, nitrogen oxides and other greenhouse gases or harmful gases are generated during power generation, which is harmful to the environment. IT6000B can avoid any of these by its regenerative function.

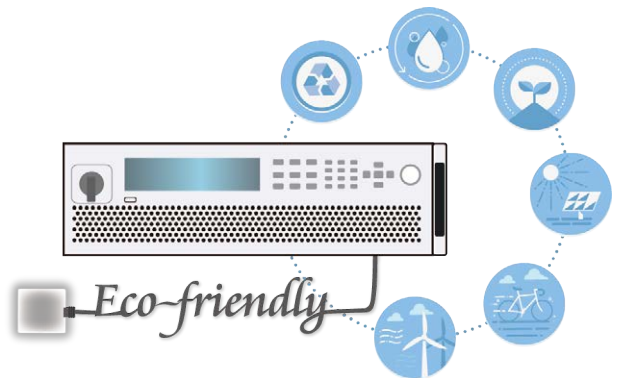

The application for solar array simulation

IT6000B optional SAS1000 solar array simulation software, users can easily use the software to output, measure, display the maximum power and track status of photovoltaic inverter in real time and record value. With the built-in EN50530, Sandia, NB/T32004, CGC/GF004, CGC/GF035 regulatory testing procedures, it is simple for users to simulate I-V curves, test the static and dynamic MPPT performance of PV inverters and generate reports. Solar simulation power supply also provides the shadow and table mode, users can enter up to 4096 points array to edit any shielded IV curve and achieve dynamic shadow effect. Or users can store 100 I-V curves under different irradiation and temperature, set operating time and order to test the long-term MPPT of photovoltaic inverters under different climatic conditions.

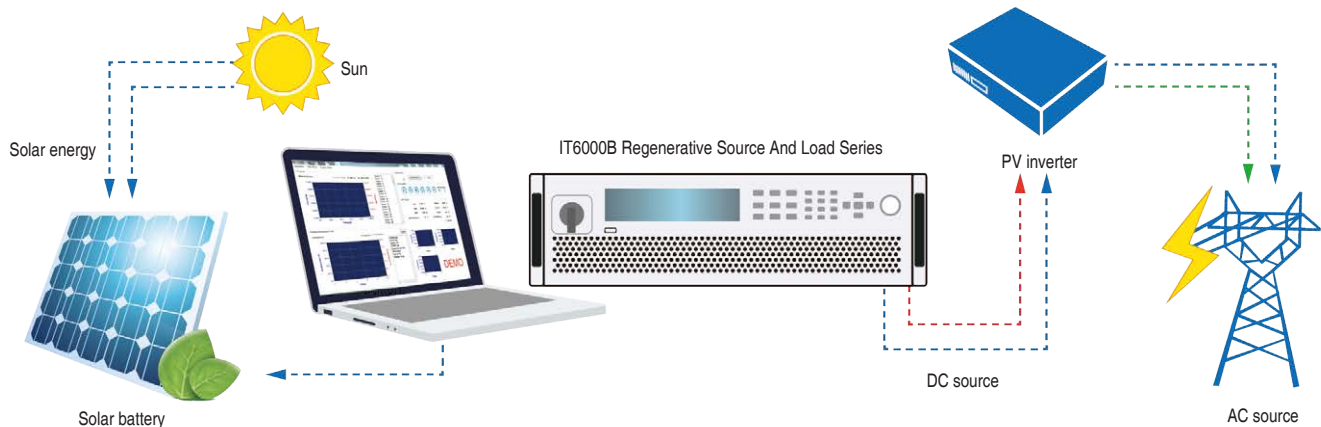

Built-in voltage curves for a variety of standard automotive voltage curves

Automotive electronics may often experience power transients during vehicle start-up and operation. To ensure that the device under test can withstand these actual transients, the tester must simulate worst-case power transient conditions during the test. According to the relevant standards of the industry, the IT6000B has built-in voltage curves for DIN40839, ISO-16750-2, SAEJ1113-11, LV124 and ISO21848 standard automotive voltage curves. Users can easily recall various waveforms directly, such as voltage drop waveform during vehicle starting up, pulse waveform and other related automotive electronics waveforms for performance tests. Available voltage grades in 12V, 24V and 48V.

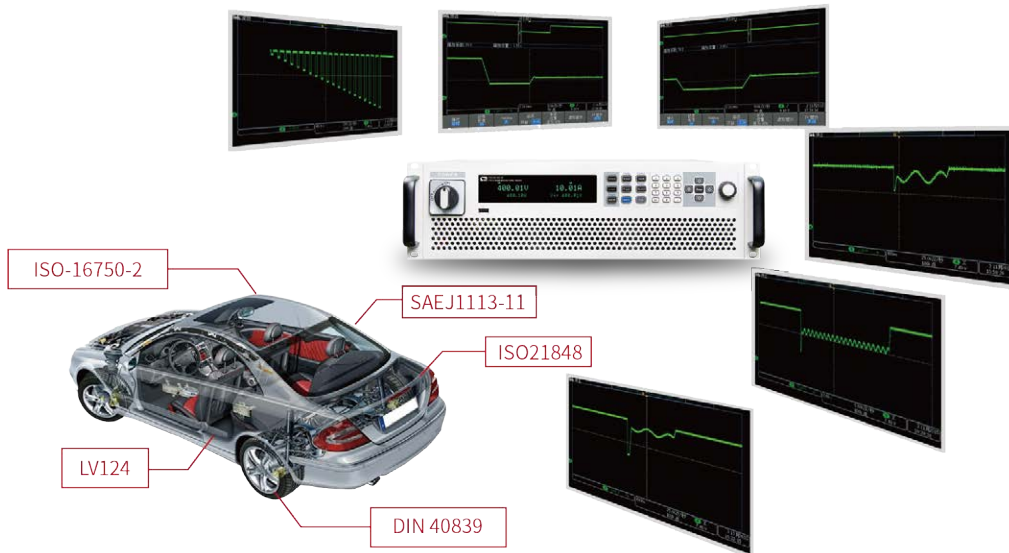

CC&CV Priority

IT6000B has CC/CV priority function which is the newest concept in the industry. It can meet different application requests such as fast speed or no overshoot and make the test more flexible. Users can choose CC/CV loop response time and loop working mode to decide the output to be voltage high speed mode or current no overshoot mode. This unique function makes it suitable for the application of high power integrated circuit test, charging and discharging test, transient simulation test of automotive electronics etc.



CV priority

Starting up: surge current over range, high speed voltage

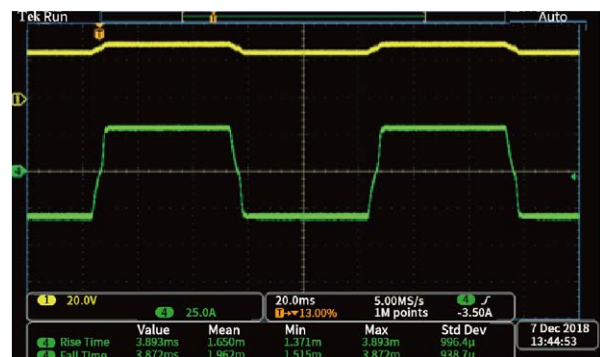

CC priority

Battery charging and discharging: seamless switching, no overshoot

Excellent parallel technology

- All the function and performance will be the same as standalone unit
- No need to calibrate after paralleling
- Fiber transmission, good for anti-interference
- Digital paralleling, fully insulated, good for protecting DUT

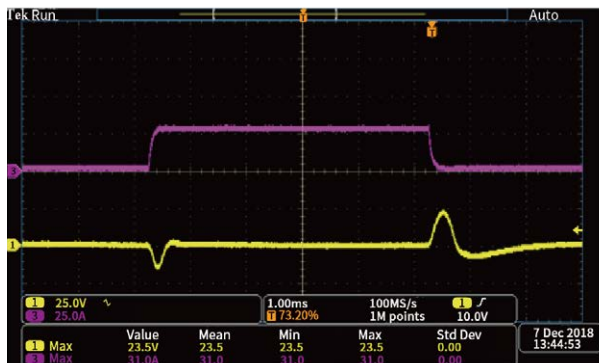

Standalone unit
IT6006B-500-30 500V 30A 6000W
Setting: voltage 100V current 28A
Load current: 30A

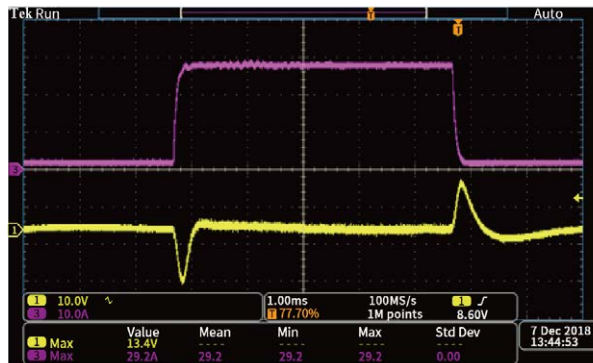

2 units IT6006B-500-30
Setting: voltage 100V current 56A
Load current: 60A

* Yellow- output voltage
Purple- output current



The diagrams above show that the dynamic waveforms are the same after the IT6000B units are paralleled. Master and slave can keep high speed response without delay simultaneously.



- Falling speed is almost the same after paralleling



- Rising speed is even faster than standalone unit



- Dynamic waveform keeps the same after paralleling

Application-Photovoltaic energy storage integrated machine

Photovoltaic energy storage integrated machine is a device of DC-AC converter used in combined power generating of photovoltaic and energy storage system. It can coordinate the output of photovoltaic and energy storage batteries, stabilize the power fluctuation of the batteries and output qualified AC power by the technology of energy storage converting.

- IT6000B can precisely simulate I-V curve of solar panel.
- IT6000B can simulate batteries by its battery simulation function.
- IT7900P regenerative grid simulator, simulate grid input.
- Three testing ways can be done by simulation of various power units: Battery input, AC input, PV input to converter.
- The independent load mode of IT6000B can proceed discharging test of batteries.

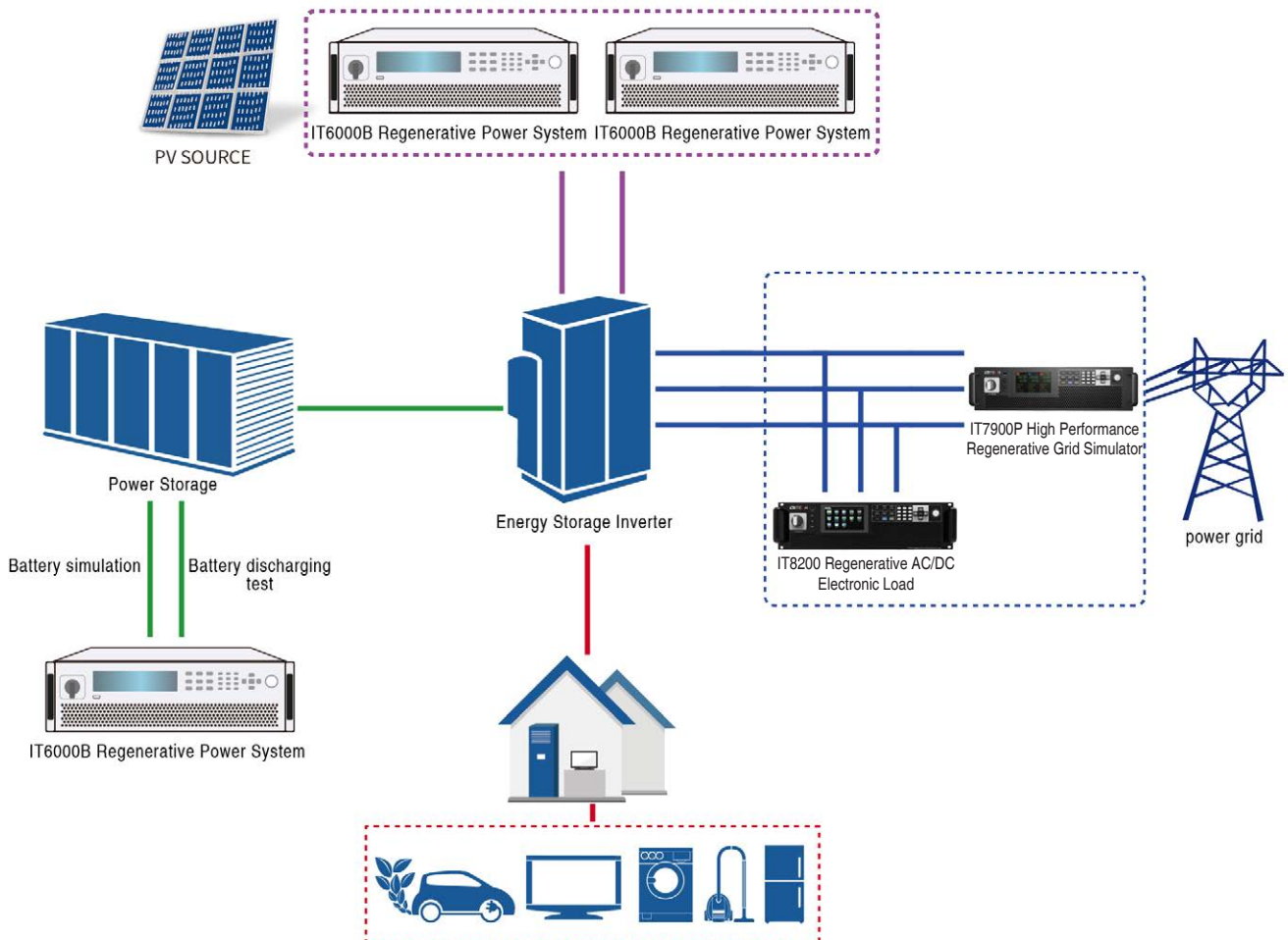

Optional accessories



Power Supply

Accessories for cabinet		
Model	Specification	Description
IT-E4029-15U	IT15U cabinet	907.6mm×800mm×550mm
IT-E4029-27U	IT27U cabinet	800mm×600mm×1362.75mm
IT-E4029-37U	IT37U cabinet	550mm×800mm×1764.35mm
IT-E4001 *1	Power on/off control	power on/off, emergency stop , AC input
IT-E169	optic cables for parallel communication	for parallel communication between cabinet
IT-E258/E/U-15U*2	5m power cord for 15U unit	EN US CN and other area
IT-E258/E/U-27U*2	5m power cord for 27U unit	EN US CN and other area
IT-E258/E/U-37U*2	5m power cord for 37U unit	EN US CN and other area
IT-E165A-250 *3	Anti-reverse protection unit	750V/250A
IT-E165A-400 *3		750V/400A
IT-E165A-500 *3		900V/400A
IT-E165B *4	Anti electromotive force protection unit	avoid current back flow

Software		
Model	Specification	Description
BSS2000	Battery simulation software	BSS2000/BSS2000Pro/BSS2000M
FCS3000	Fuel cell simulation software	Single channel
SAS1000	Solar array simulation software	SAS1000/SAS1000L/SAS1000M

*1 Only available with instrument and cabinet

*2 contact us for details

*3 DUT voltage/current should be in the rated range of IT-E165A

*4 DUT voltage/current should be in the rated range of IT-E165B

Various interfaces

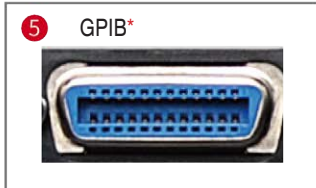
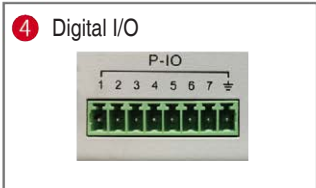
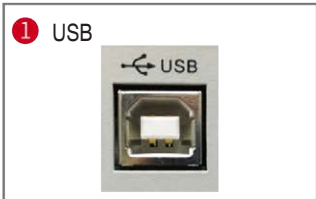
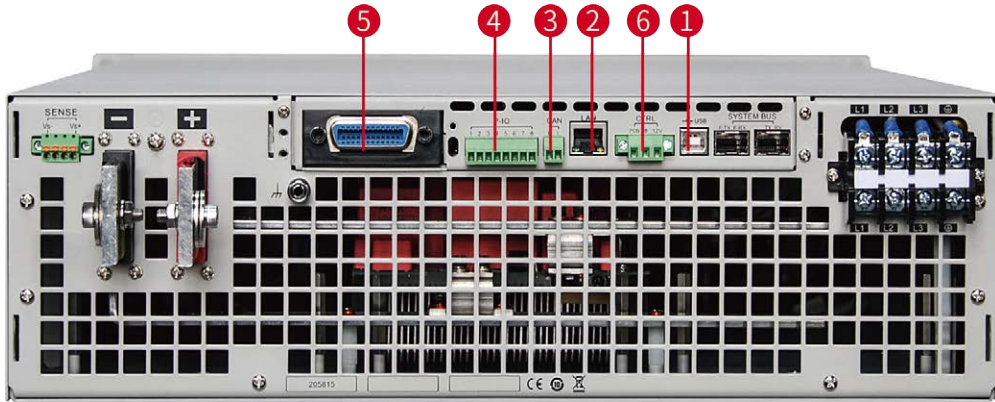

* Optional GPIB or Optional RS232 & Analog

IT6000C Series Bidirectional Programmable DC Power Supply



Feature

- Adopts SiC-base technology, integrates source and sink function in one unit
- Stand-alone max. output power 144kW, expandable up to 2 MW by paralleling
- Voltage range: 0 to 2250V
- Current range: 0-2040A (single cabinet); 0-8000A (after parallel connection)
- High power density up to 18kW in compact 3U rack space
- Bi-directional power transfer, seamless switch between sourcing and sinking
- High regenerative efficiency up to 95% *1
- Standard Built-in USB/CAN/LAN/digital IO interface, optional GPIB/analog & RS232
- Full protections: support OVP, \pm OCP, \pm OPP, OTP, power down protection, anti-islanding protection
- Support control loop priority mode setting , different loop speed can be set
- Partial pre-compliant with LV123, LV148, DIN40839, ISO-16750-2, SAEJ1113-11, LV124 and ISO21848 testing standards
- Could be used as battery cycler and support various battery charging and discharging modes, such as CC/CV/CP
- Built-in function generator, support arbitrary-waveform generating
- Could be used as PV simulator, simulating the PV curves (with optional SAS1000 software)
- Support multiple working modes, rising and falling time can be adjustable.
- Support data saving and the shortest interval of sampling is 10us
- Could be used as battery simulator (with optional BSS2000 Software)
- Strong dynamic driving profile simulation function, up to 10,000,000 points

*1 The regenerated power is for local grid purpose, not for public grid purpose

IT6000C series is a bi-directional programmable DC power supply which adopts the third generation SiC-base technology. It integrates the source and sink function in one unit. Based on these two functions, IT6000C offers the functionality of two-quadrant operation. The regenerative capability enables the energy consumed to be put back onto the grid cleanly, saving costs from energy consumption and cooling, while not interfering with the grid.

IT6000C series provide max. output voltage up to 2250V, support master-slave paralleling with averaging current distribution , max. output power up to 2MW. Built-in waveform generator supports generating arbitrary waveforms, and import LIST files for waveforms via front panel USB port. IT6000C is the combination of high reliability, high efficient setting, safe and multiple measurement functions.

Bi-directional energy, seamless transfer

The IT6000C Series combines source and sink functions in one. Unlike traditional power supplies and E-loads, for which there will be short transitions and inconsistencies in the middle of positive and negative current switching, IT6000C is a standard high-speed bidirectional power supply, enables high-speed source and sink current fast and continuous seamless switching, effectively avoiding voltage or current overshoot, and can be widely used in Energy storage device test, like batteries, cell packaging equipment and battery protection board testing.

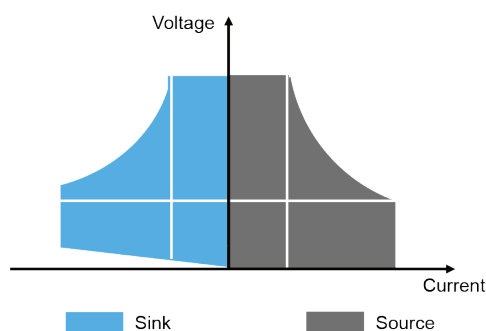



Application

01 Renewable Energy		Solar Charger		Micro Inverter	Battery Pack	PV Inverter
02 Automotive	Automotive Motors		Car Charger	Automotive Electronics		Bidirectional DC/DC Converter
03 High-speed testing	Telecom	Power semiconductor components	High speed electronic test		LED products	Aviation
04 High-power testing		UPS	Electric motor/generator	Consumer products	Electro plating/welding	ATE systems

Power Supply

	Model	Current	Power		Model	Current	Power		Model	Current	Power
80V	IT6005C-80-150	150A	5kW	300V	IT6006C-300-75	75A	6kW	500V	IT6006C-500-40	40A	6kW
	IT6010C-80-300	300A	10kW		IT6012C-300-150	150A	12kW		IT6012C-500-80	80A	12kW
	IT6015C-80-450	450A	15kW		IT6018C-300-225	225A	18kW		IT6018C-500-120	120A	18kW
	IT6030C-80-900	900A	30kW		IT6036C-300-450	450A	36kW		IT6036C-500-240	240A	36kW
	IT6045C-80-1350	1350A	45kW		IT6054C-300-675	675A	54kW		IT6054C-500-360	360A	54kW
	IT6060C-80-1800	1800A	60kW		IT6072C-300-900	900A	72kW		IT6072C-500-480	480A	72kW
	IT6075C-80-2040	2040A	75kW		IT6090C-300-1125	1125A	90kW		IT6090C-500-600	600A	90kW
	IT6090C-80-2040	2040A	90kW		IT6108C-300-1350	1350A	108kW		IT6108C-500-720	720A	108kW
	IT6105C-80-2040	2040A	105kW		IT6126C-300-1575	1575A	126kW		IT6126C-500-840	840A	126kW
	IT6120C-80-2040	2040A	120kW		IT6144C-300-1800	1800A	144kW		IT6144C-500-960	960A	144kW

	Model	Current	Power		Model	Current	Power		Model	Current	Power
800V	IT6006C-800-25	25A	6kW	1500V	IT6018C-1500-40	40A	18kW	2250V	IT6018C-2250-25	25A	18kW
	IT6012C-800-50	50A	12kW		IT6036C-1500-80	80A	36kW		IT6036C-2250-50	50A	36kW
	IT6018C-800-75	75A	18kW		IT6054C-1500-120	120A	54kW		IT6054C-2250-75	75A	54kW
	IT6036C-800-150	150A	36kW		IT6072C-1500-160	160A	72kW		IT6072C-2250-100	100A	72kW
	IT6054C-800-225	225A	54kW		IT6090C-1500-200	200A	90kW		IT6090C-2250-125	125A	90kW
	IT6072C-800-300	300A	72kW		IT6108C-1500-240	240A	108kW		IT6108C-2250-150	150A	108kW
	IT6090C-800-375	375A	90kW		IT6126C-1500-280	280A	126kW		IT6126C-2250-175	175A	126kW
	IT6108C-800-450	450A	108kW		IT6144C-1500-320	320A	144kW		IT6144C-2250-200	200A	144kW
	IT6126C-800-525	525A	126kW								
	IT6144C-800-600	600A	144kW								

* This information is subject to change without notice

High energy regenerative efficiency

The IT6000C series has a unique energy regenerative function that can regenerate electrical energy and then directly use it in the plant instead of consuming it in the form of heat. The regenerative efficiency can reach up to 95%, which not only will greatly reduce the user's electricity cost, but also avoid the using of air conditioning or expensive cooling systems.



Application for solar array simulation

IT6000C configured with optional ITECH SAS1000 Solar Array Simulation Software, users can easily use the software to output, measure, display the MPP tracking status of photovoltaic inverter in real time simulation and record value. Built-in EN50530, Sandia, NB/T32004, CGC/GF004, CGC/GF035 standard testing procedures, it is convenient for users to test the static and dynamic MPPT performance of PV inverters and generate reports. Solar simulation power supply also provides the shadow and table mode operation, the user can enter up to 4096 points array to edit any shielded IV curve to achieve dynamic shadow effect simulation and also can store 100 I-V curves under different irradiation and temperature to test the long-term maximum power tracking performance of photovoltaic inverters under different climatic conditions.

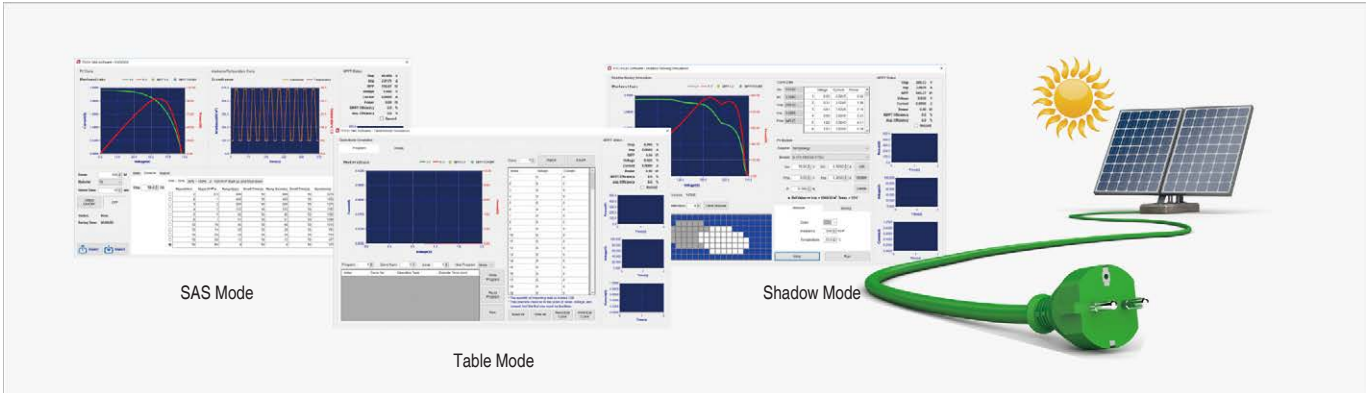

Built-in voltage curves for a variety of standard automotive voltage curves

Automotive electronics may often encounter power transients during vehicle start-up and operation. To ensure that the device under test can withstand these actual transients, the tester must simulate worst-case power transient conditions during the test. According to the relevant standards of the industry, the IT6000C series has built-in standard automotive voltage curves LV123, LV148, DIN40839, ISO-16750-2, SAEJ1113-11, LV124 and ISO21848. The User can directly recall the vehicle's starting voltage drop, various automotive electronic tests, pulse waveforms and other related automotive electronics for performance tests. Available voltage grades in 12V, 24V and 48V voltage levels.

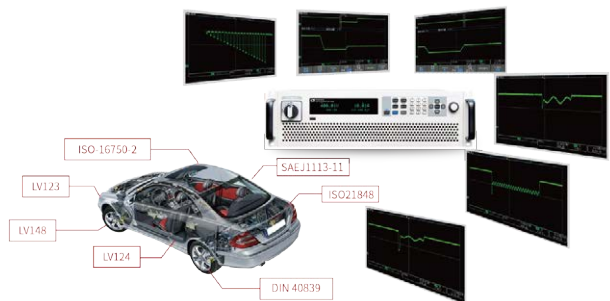

Control loop CC/CV priority mode

IT6000 C series continues to adopt ITECH-developed innovative CV & CC priority concept, which will help customers effectively and flexibly solve their various tough problems in test applications request for high speed and no over shoot power supplies. Customers can select CV or CC priority to adjust the speed of the loop circuit, to decide output with the high-speed voltage or current with no overshoot. It is applicable for high-power integrated circuit test, charging/ discharging test, and the transient simulation/ characteristic test of automotive electronics.



Control loop CV priority mode

After setting the high-speed voltage mode, the voltage output faster and bring with an inrush current which is higher than the current range.

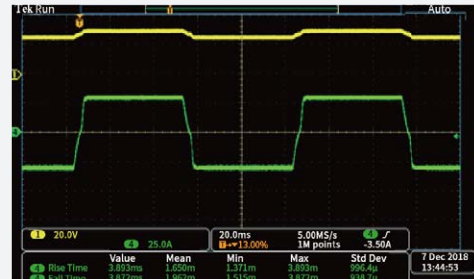

Control loop CC priority mode

battery charging and discharging, high speed seamless switch, effectively suppress the current overshoot.

Parallel connection technology

Advantages:

- IT6000 BCD series adopts ITECH parallel connection technology
- Optical fiber transfer between master and slave, guarantee perfect performance of anti-interference
- The parameters will not change after parallel connection
- Adopt Optical fiber isolation technology, effective protection of the device and DUT
- Calibration is not requested after parallel connection

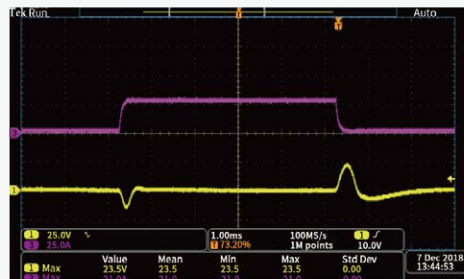

Stand-alone unit

Stand-alone unit: IT6006C-500-40 500V 40A 6000W
Input voltage: 100V Input current: 28A Sinking current: 30A

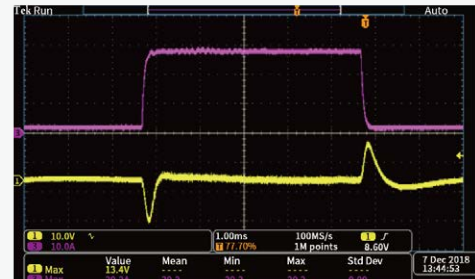

Paralleled units

2 sets IT6006C-500-40 paralleled
Input voltage 100V Input current 56A Sinking current 60A

* Yellow waveform: output voltage Violet waveform: output current



From the above waveforms comparison:

we can see the paralleled IT6000C can output the same dynamic response waveform as the original single unit does, and show no-delay fast synchronized response.

Falling speed

No substantial changes comparing with single unit after parallel connection

Falling speed

Even faster rising speed, comparing with single unit after parallel connection

Falling speed

consistent with single unit waveform after parallel connection

IT6000D Series High Power Programmable DC Power Supply



Feature

- Master-slave parallel, the power can be paralleled up to 2 MW
- Current range: 0-2040A (single cabinet); 0-8000A (after parallel connection)
- The adoption of high frequency switching structure supports the automatic switching among CV, CC and CP
- Provides various protections: OVP, OCP, OPP, OTP, protection of power failure and UVP
- Supports data recording function, can continuously record the Max, Min, Average values of output voltage and current, and it can automatically execute data by sequence
- Power efficiency up to 92%
- High power density supported by advanced SiC technology is up to 3U/18kW
- Supports external data recording function, internal buffering, and the PC will periodically read data from the power supply, the shortest interval of sampling is 10 μ s
- Built-in communication interfaces of USB/CAN/LAN/Digital IO, and optional interfaces of GPIB, Analog and RS232
- Supports SCPI protocol, built-in Web server

IT6000D, single channel output programmable DC power supply, is applicable in laboratories and automatic test system to provide high-power and stable DC supply. The feature of autoranging output enables a wide range of voltage and current combinations at full power, unprecedentedly flexible.

IT6000D Series has wide range of applications and its current up to 8000A, as well as its voltage up to 2250V. Besides, IT6000D provides multi built-in communication interfaces to simplify and accelerate the testing development. The compact 3U design saves rack space. Multi units of the same model can be paralleled easily to have higher power and the maximum power can reach up to 2 MW.

Applications

- Applications
- Data center
- Server power supply
- High voltage UPS
- Telecommunications power
- Solar battery panels
- On-board-charger
- Battery pack
- Energy storage system
- Electrical vehicle charging station
- Fuel battery
- Automatic Test Equipment
- High precision electroplating, sputtering, surface treatment

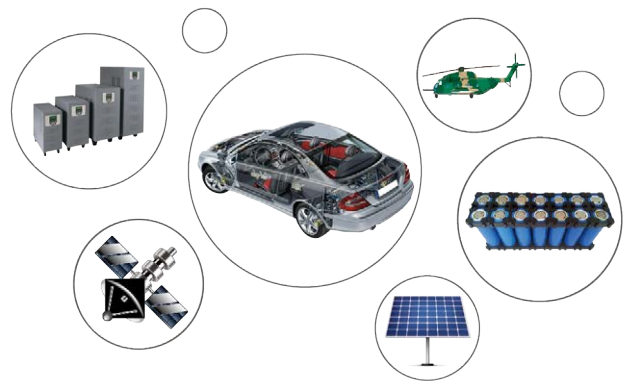

3U/18kW High power density

High power density of 18kW in 3U size, IT6000D series DC power supply has good capability of low output ripple and noise, power grid disturbance adjustment, load regulation and fast transient response. Standalone unit with voltage range of 80V-2250V, current of 450A-20A. Its wide range allows the devices to be used in every testing step of R&D, products testing and production.

CC & CV priority

IT6000D series keep the CC/CV priority function, which fit different application requests such as fast speed or no overshoot, making the whole test more convenient. Users can choose CC/CV loop response time and loop working mode to decide the output to be voltage high speed mode or current no overshoot mode. This unique function makes it suitable for the application of high power integrated circuit test, charging and discharging test, and transient simulation test of automotive electronics etc.

Output features

Comparing with the conventional design, the IT6000D has much better output range to satisfy various requirement. Featured as its wide auto range output, it can cover more applications. One standalone unit equals to 3-5 traditional power supplies and 3 units equals to 10-13 traditional power supplies. This makes it easier to build a system and save space at the same time.

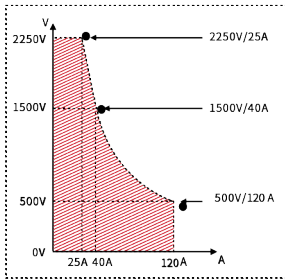

CP curve of IT6000D

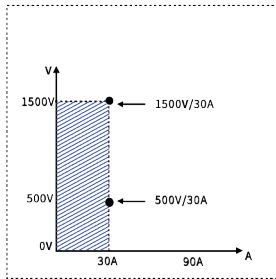

Output feature of conventional power supply

Parallel technology

- IT6000 has adopted ITECH parallel technology
- All the function and performance will be the same as standalone unit
- No need to calibrate after paralleling
- Fiber transmission, good for anti-interference
- Digital paralleling, fully insulated, good for protecting DUT

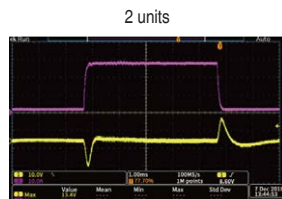

2 units
IT6006D-500-40
Setting: voltage 100V current 56A
Load current: 60A

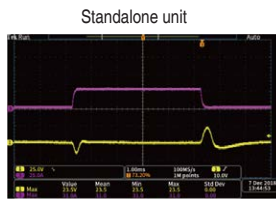

Standalone unit
IT6006D-500-40 500V/40A/6kW
Setting: voltage 100V current 28A
Load current: 30A

Parallel technology

When the higher power is required, IT6000D series can be paralleled with several same model units. The system will be built faster and more flexible.

- Parallel unit up to 64 units
- Master / Slave parallel operation up to 2MW
- Parallel current up to 2040A
- Smart Master / Slave mode make the parallel connection easy and fast
- High power density for standalone unit and parallel connection
- Precise synchronization to ensure the whole power system synchronization after parallel connection.

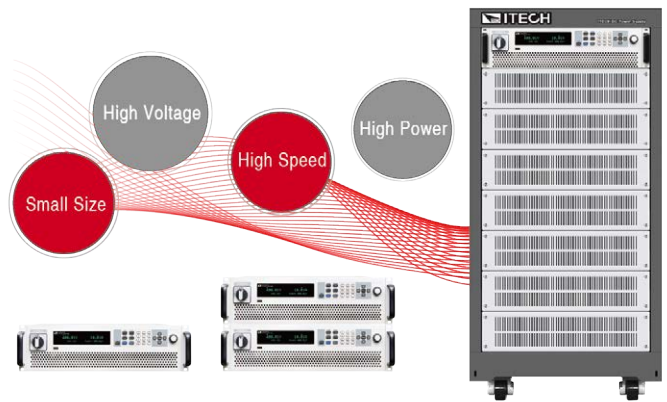

Multiple interfaces

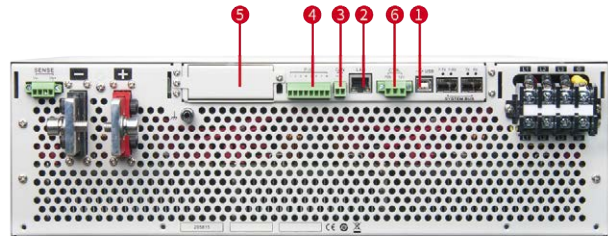

<p>1 Standard USB interface</p>	<p>2 Standard LAN interface</p>	<p>3 Standard CAN interface</p>
<p>4 Standard I/O interface</p>	<p>5 Optional GPIB interface</p>	<p>6 External control interface</p>

* Optional GPIB or Optional RS232 & Analog

IT6400 Bipolar DC Power Supply / Battery Simulator

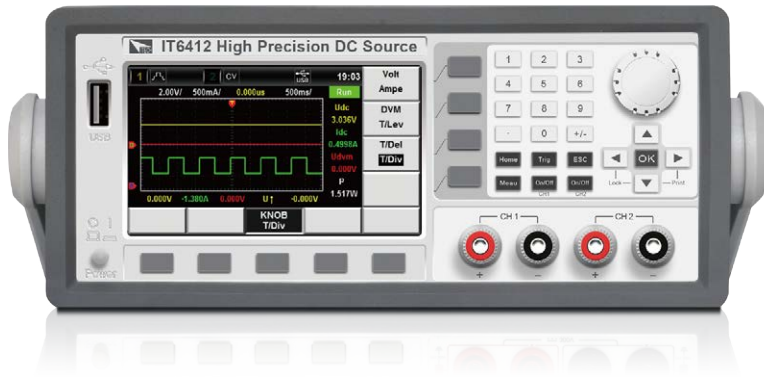

Applications

Portable battery-powered product testing, mobile power testing, battery testing, etc.

Feature

- Maximum output power of single channel up to 150 W, output voltage max. ± 60 V, output current max. ± 10 A
- High performance color LCD display, dual channel output display main interface*1
- Bipolar dual-range output
- Accurate Battery Simulation
- Oscilloscope waveform display (DSO)
- Ultrafast transient response time $< 20 \mu\text{s}$
- Ultrafast voltage rising time up to $150 \mu\text{s}$
- Current display resolution up to 1 nA
- Ultra-small current ripple up to $2 \mu\text{Arms}$
- Built-in high accuracy DVM
- Variable output impedance
- Applicable to portable battery-powered products test
- LED test no overshoot current
- Relay out function achieves electrical isolation on terminals
- High speed AD sampling
- List function achieves voltage/current output as programmed
- Standard interface LAN/USB

*1 IT6402/IT6412 provides this function.

* For any GPIB interface option request, check with ITECH for availability.

The unique bipolar voltage/current output makes IT6400 series can be used as a bipolar power source or a bipolar electronic load. The battery simulating function is especially applicable for development and high speed production testing of portable, battery-operated products. IT6400 has ultrafast transient time less than $20 \mu\text{s}$ and resolution up to 1 nA . Its new designed speed shift mode achieves voltage/current fast rising and without overshoot, rising time up to $150 \mu\text{s}$. Meanwhile, the waveform display function let the test be visible and simple. IT6400 series can be widely used in portable battery-operated products test, mobile power pack test, LED test and other fields.

Model	Voltage	Current	Power	Channel
IT6402	CH1: ± 6 V CH2: $0 \sim 6$ V	CH1: ± 2 V CH2: ± 2 V	CH1: 12 W CH2: 12 W	2
IT6411	± 15 V/ ± 9 V	± 3 A/ ± 5 A	45 W	1
IT6411S	-15 V- 0 V, $0 \sim 15$ V	± 0.1 A	1.5 W	1
IT6412	CH1: ± 15 V/ ± 9 V CH2: $0 \sim 15$ V/ $0 \sim 9$ V	CH1: ± 3 A/ ± 5 A CH2: ± 3 A/ ± 5 A	CH1: 45 W CH2: 45 W	2
IT6412S	CH1: -15 V- 0 V, $0 \sim 15$ V CH2: $0 \sim 15$ V	CH1: ± 0.1 A CH2: ± 0.1 A	CH1: 1.5 W CH2: 1.5 W	2
IT6431	-15 V- 0 V, $0 \sim 15$ V	± 10 A	150 W	1
IT6432	-30 V- 0 V, $0 \sim 30$ V	± 5 A	150 W	1
IT6432S	-30 V- 0 V, $0 \sim 30$ V	± 21 mA	0.63 W	1
IT6433	-60 V- 0 V, $0 \sim 60$ V	± 2.5 A	150 W	1

Bipolar Output

IT6400 high speed linear DC source provides bipolar output, maximum output voltage of single channel up to ± 60 V, maximum output current up to ± 10 A. With multi-functional and high-performance output, IT6400 meets various of test needs. As dual-channel bipolar DC source, it is available for easy-shifting dual range output with each channel. Users can switch according to test requirements, one unit IT6412 can finish mobile and charger test independently, easy to use.



Oscilloscope Waveform Display Function

IT6400 provides waveform display function based on sample data. The Voltage/ current waveform is visible or invisible by your option, and can be adjusted by the knob. The graphic on the newly design colorful display can be saved, achieves easy and effective oscilloscope experience.

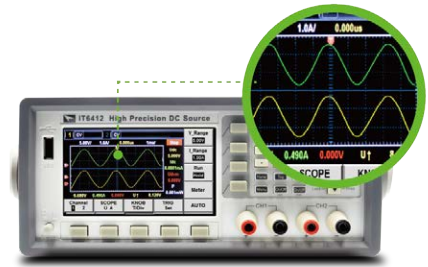

Battery Simulating Function

With the unique current bipolar design and 0~20 Ω variable output impedance, IT6400 is applicable to types of portable battery charge-discharge tests. Simulating the battery charge-discharge features and assist with other tests are also reliable. One equipment, diversified applications.

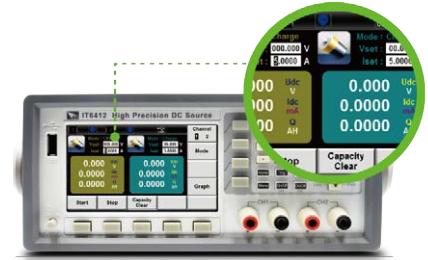

Portable battery-operated products test

Ultrafast Transient Time <20 μs

IT6400 has ultrafast transient ability, the transient time for recovering to 50 mV is less than 20 μs when 50%-100% loaded. New designed speed shift mode achieving voltage/current high speed rising waveform without overshoot, supports stable power supply, and ensures the security, especially for LED test.

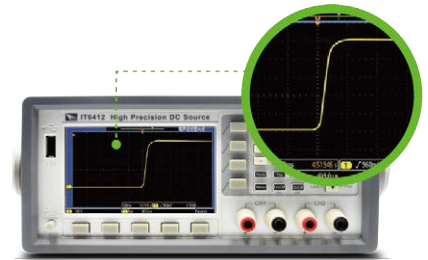

LED test without overshoot current

DVM Test Function

Abundant electrical basic measuring functions are available on IT6400. High accuracy DVM is built in each channel with readback resolution up to 1 mV. The measured data will be visible on specified channel screen. The changes of voltage waveform measured by DVM can be observed by oscilloscope display function.



Applications

- Portable battery-operated products test
- Mobile power pack test
- Battery protection board test
- Battery test
- LED test
- Power amplifier Test
- DC / DC converter test

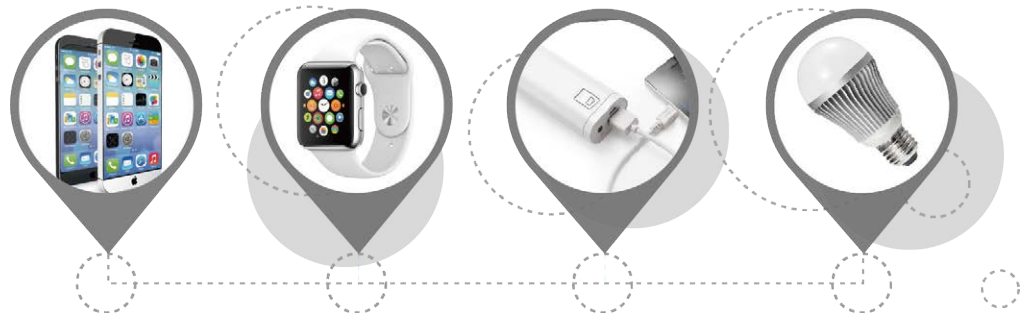

IT6500 Wide-range High-power DC Power Supply



With ITECH's latest technology, the IT6500 series offers a full-featured high-performance power test solution. With fast response these DC power supplies provide users with a new level of power supply performance. From 800W to 6kW, the maximum output voltage and current is up to 1000V and 240A respectively.

Applications

Electric Vehicle Battery Test, Battery Simulation, LED, Automotive Electronics, Solar Panel I-V Curve Simulation

Choose the right power supplies that fit your test requirements

IT6502D/IT6512/IT6512A/ IT6513/IT6513A	Good performance and compact size, designed for general purpose testing in R&D and production.
IT6500C series	Multi-functional and with fast response. These power supplies are designed for continuous source and sink testing requirements. Such as automobile electronics, solar panel IV simulation, DC motors, batteries etc.
IT6500D series	High performance with stable output, designed for automobile, green energy, high speed testing, high-power testing etc.

800W	IT6502D 80V/60A/800W					
1200W	IT6512/A 80V/60A/1200W	IT6513/A 150V/30A/1200W				
1800W	IT6512C/D 80V/120A/1800W	IT6513C/D 200V/60A/1800W	IT6514C/D 360V/30A/1800W	IT6515C/D 500V/20A/1800W	IT6516C/D 750V/15A/1800W	IT6517C/D 1000V/10A/1800W
3kW	IT6522C/D 80V/120A/3kW	IT6523C/D 200V/60A/3kW	IT6524C/D 360V/30A/3kW	IT6525C/D 500V/20A/3kW	IT6526C/D 750V/15A/3kW	IT6527C/D 1000V/10A/3kW
6kW	IT6532C/D 80V/240A/6kW	IT6533C/D 200V/120A/6kW	IT6534C/D 360V/60A/6kW	IT6535C/D 500V/40A/6kW	IT6536C/D 750V/30A/6kW	IT6537C/D 1000V/20A/6kW

* For higher power test, please contact ITECH.

FAST Fast response

Independent settable slew rate in different modes

IT6500C series can be used as a power supply and an electronic load. As a power supply, CV, CC, CP modes are available. As an electronic load, CC and CP mode are available. IT6500C supports independent adjustable rise/fall time setting in different modes.

For every single model of IT6500C/D series, no matter it is a single unit or multiple units paralleled together, the rise and fall time of each power supply in IT6500C/D series are the same. Take IT6522C as an example:

- Within 30V voltage range, with 0-90% load, up and down speed <3ms
- Falling time of no load with voltage at full scale:
Without power dissipater unit, falling time <30ms
With power dissipater unit, falling time <5ms
- Dynamic response time <3ms

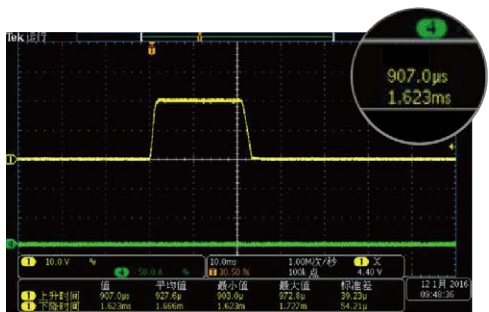

DC ratings of single unit IT6522C: 80V/120A/3000W
Voltage ratings: 10V
Current ratings: 120A
Load Current: 0A

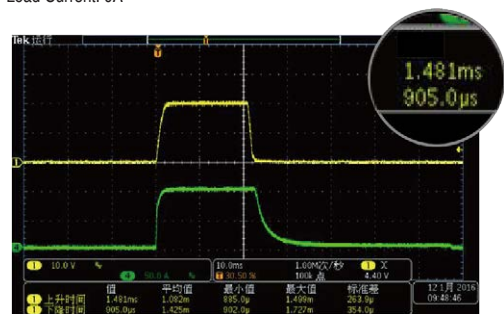

DC ratings of single unit IT6522C: 80V/120A/3000W
Voltage ratings: 10V
Current ratings: 120A
Load Current: 100A

No matter whether it is in the power supply mode (CV, CC, CP) or in the electronic load mode (CC, CP), IT6500 series has adjustable rise and fall time, and the settable range is 1ms-24h.

CC/CV PRIORITY Fast curve changing without overshoot CC & CV Priority Function

To conquer the demanding testing requirements existing for a long time in various applications, ITECH developed an innovative industry-leading CV & CC priority concept. The IT6500 is available for high-speed test applications with-out overshoot. Users can chose the desired output mode. Voltage high-speed mode or current no overshoot mode by choosing the loop response speed and loop operation mode. It is suitable for high-power integrated circuit test, charging / discharging test, solar array simulation and the transient simulation / characteristic of automotive electronics.



Fast voltage built with turn-on over range inrush current (CV-High, CC-Low, CV takes precedence)



Battery charging / discharging test with seamless and no overshoot switching (CV-High, CC-High, CC takes precedence)

Target Maintain excellent performance after paralleling

Built-in paralleling of multiple power supplies with even current distribution

IT6500C supports multiple power supplies paralleling together in master-slave mode. Even further it can ensure that each power supply equally shares the load current and they all remain in the desired mode. In the traditional sense, when paralleling power supplies together, different power supplies will operate in different operation modes. For instance, when two sets of power supplies are paralleled together, one will offer a majority of current in CC mode, and the other will offer only a small part of current in CV mode, which will degrade certain power supplies' performance specifications. The even current distribution ability of the IT6500 ensures each power supply equally shares the load current without degrading the performance specifications. When paralleling multiple IT6500 the combined system has all the same functions as a standalone unit. That is a great way to add power flexibility to your test system. What is particularly unusual is that after the expansion of power, IT6500C can still maintain the excellent dynamic characteristics of the single unit to meet the I-V characteristic curve testing demanding a variety of high-power high-speed applications.

Low voltage & high current test

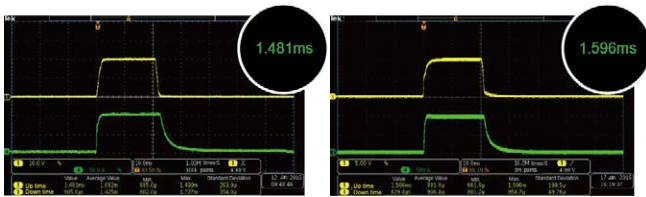

Standalone set IT6522C
80V, 120A, 3000W
Voltage ratings: 10V
Current ratings: 120A
Load current: 100A

8 sets of IT6522C paralleling together
Voltage ratings: 10V
Current ratings: 960A
Load current: 800A

High voltage & low current test

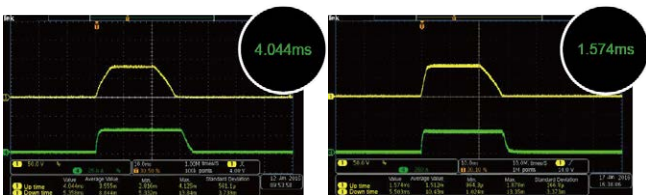

Standalone set unit IT6522C
80V, 120A, 3000W
Voltage ratings: 80V
Current ratings: 120A
Load current: 30A

8 sets of IT6522C paralleling together
Voltage ratings: 80V
Current ratings: 960A
Load current: 300A

Dynamic response test

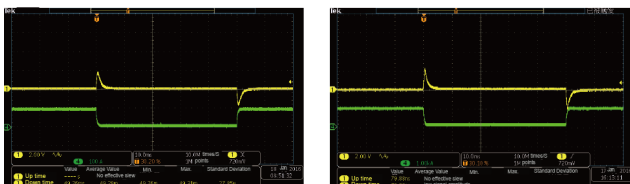

Standalone set IT6522C
80V, 120A, 3000W
Voltage ratings: 10V
Current ratings: 120A
Load current:
Level A=10A
Level B=100A
F=10 Hz

8 sets of IT6522C paralleling together
Voltage ratings: 10V
Current ratings: 960A
Load current:
Level A=100A
Level B=800A
F=10Hz

* Figure: Voltage-Yellow, Current-Green

From the tests, we conclude:

1. Voltage rise time: 8 units of IT6522C paralleling together, the voltage rise time is faster than single unit operation.
2. Fall time: parallel units remain the same as single unit.
3. Dynamic response waveforms: parallel units remain the same as single unit.



Simple programming on the front panel (List)

Similar to other modern ITECH products, the IT6500 series provides a user friendly front panel for quick programming without the need for external software.

In list mode, the IT6500 series can store, recall and run the preset customized program sequences via front panel programming. Users can edit the voltage/current value & the time of each step in advance and provide the power supply with a trigger signal. Then the preset sequences / waveform will be executed automatically according to the defined LIST. That's especially suitable for the applications such as DC / DC converters, inverters voltage drop test, engine start-up simulation, battery charging / discharging tests, product life cycle tests and aircraft test etc.

Waveforms programmed with IT6500 series by engineers

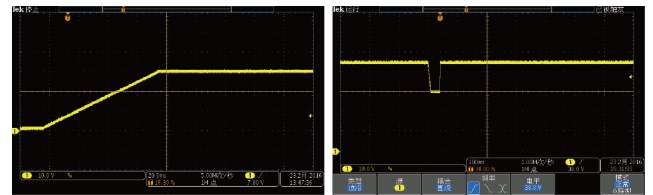

Soft Start Testing

D/D Converter Sag Testing

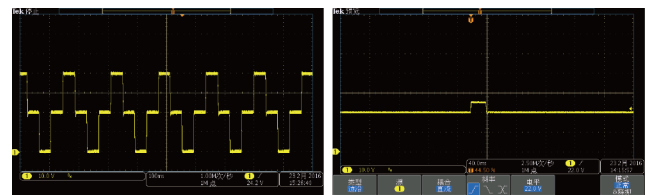

Voltage Step Waveform

D/D Converter Surge Testing

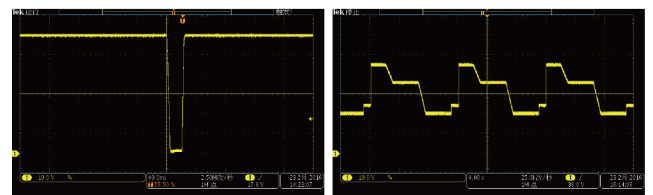

D/D Converter Cycle drop Testing

Life Cycle Testing

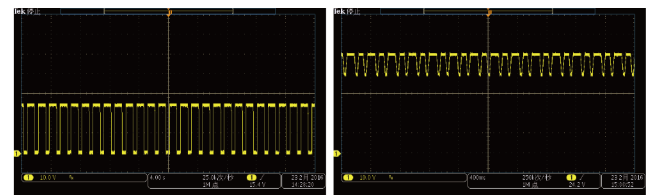

Pulse Charge of Battery

Line Regulation Testing

*Output test with no load

Functions for special applications

Programmable output impedance

In battery charging and discharging test, the changes of internal resistance should be taken into account. For enhancing test precision, IT6500C series power supply provides built-in internal resistance setting function which can simulate battery operation status in real-case.

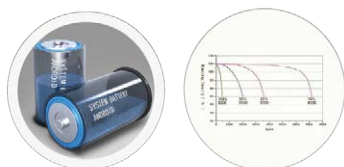

Multiple actual working status simulation of batteries

Solar panel I-V curve simulation function

IT6500C series high power DC power supply is equipped with SAS1000 solar array simulation software, which can accurately simulate the solar array I-V curve. With built-in EN50530 / Sandia / NB/T32004 / CGC/GF004 / CGC/GF035 SAS module. Users can set the parameters to simulate I-V curve characteristic output and generate reports. These benefit much in test of the static & dynamic maximum power tracking performance of photovoltaic inverters.

* SAS1000 solar array simulation software is available for choice



* Figure: Voltage-Yellow, Current-Green

Built-in standard automotive power network voltage curves

The automobile electronics devices must tolerate the dropouts or surges from power turn-on or turn-off transient. For these tests, it is necessary to simulate the worst-case power transient conditions. IT6500C series power supply provide built-in DIN40839, ISO-16750-2, SAEJ1113-11, LV124 and ISO21848 testing curves. Users can select any built-in curve to do the DUT performance test directly according to their demand. 12V, 24V and 48V are available for choice.

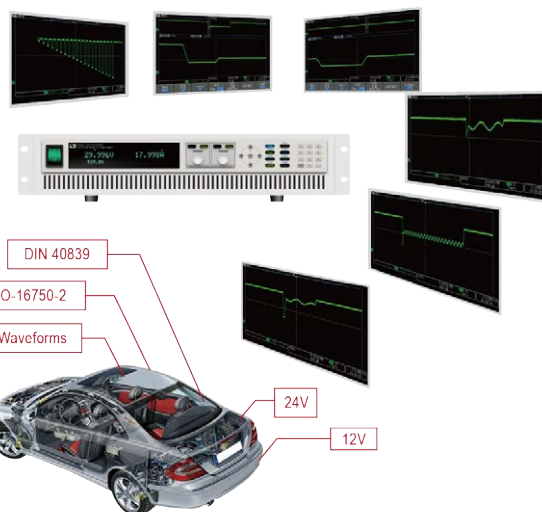

Multiple built-in interfaces*

In conventional high power test instrument, extra interfaces add cost. In the IT6500 series all the implemented interfaces are built-in standard. Simplifying the configuration process and adding flexibility to change interface used without adding additional cost.

Cost saving	IT6500C	IT6500D	IT6512 IT6513	IT6502D IT6512A IT6513A
Analog control interfaces	√	√	√	√
USB	√	√	√	√
RS232	√	√	√	√
RS485	-	-	√	√
LAN	√	√	-	-
CAN	√	√	-	-

* For any GPIB interface option request , check with ITECH for availability

Full protections

Integrating protection measures into test instruments is critical and high cost especially in high power test. To provide fully protections for DUTs, IT6500 series integrate multiple fast protection measures.

These protection capabilities include:

- CC & CV Priority Function to avoid unwanted overshoot
- Power Supply mode: OVP,OCP,OPP
- Electronic Load mode: OCP,OPP,OTP (IT6500C)
- Anti-reverse protection (optional)
- Turn-off protection

Under voltage protection (UVP)

IT6900B Wide-range Programmable DC Power Supply



Applications

DC-DC power module, battery charging and sensors, etc.

Feature

- VFD display
- Adjust voltage and current via knob or numerical key pad
- High accuracy and high resolution
- Adjust digital step value via cursor
- Output voltage and current values accordance with procedure
- Output Timer(0.1 ~ 99999.9S) Function
- Low ripple and low noise
- Remote Sense Function
- Intelligent fan control
- Rich SCPI instructions to facilitate the formation of intelligent test platform
- Support front and rear panel output
- Optional external analog function
- Standard communication interface RS232/USB/RS485*

* For any GPIB interface option request, check with ITECH for availability

Model	Voltage	Current	Power	Size
IT6922B	60V	5A	100W	1/2 2U
IT6932B	60V	10A	200W	1/2 2U
IT6933B	150V	5A	200W	1/2 2U
IT6942B	60V	15A	360W	1/2 2U
IT6952B	60V	25A	600W	1/2 2U
IT6953B	150V	10A	600W	1/2 2U

IT6900B series wide range programmable power supply has built-in standard RS232, USB, RS485 and analog interface, supports SCPI protocol, facilitate remote control, industrial PLC control and the formation of intelligent test platform. Remote compensation terminals avoid the problem of inaccurate testing caused by voltage drop on the wire. Low ripple, low noise and built-in digital voltmeter make IT6900B easy to do external measurement. IT6900B can be widely used in testing DC-DC power supply module, battery charging and sensors and other test areas.

Auto-range Function

IT6900B series power supply can achieve the combined output of multiple voltage and current at a fixed power. Single power supply can meet different DUT tests with high voltage low current or high current low voltage, at the same time, because the output of voltage and current is controlled by the limit power, it will show the switching of voltage and current auto ranging.

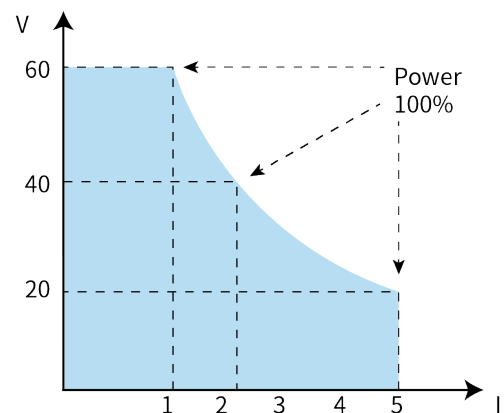

I-V Curve Graph



Remote Sense

In order to avoid the voltage drop caused by the length of the wire connecting the load, the remote test allows measurement directly on the terminal of the test object to improve the measurement accuracy. S +, S - is the remote measurement terminal, +, - is the output positive and negative terminals. When using the remote measurement function, it is necessary to disconnect the wires connected to the "+, -" terminals and lead S +, S - to the test object.

List Mode

List mode allows user to create a sequence of steps, store it into the power supply's non-volatile memory and execute the input parameters for generating a list include the name of the list file, the input steps (no more than 150 steps), the step time (the minimum is 100mS) and the value of each step.

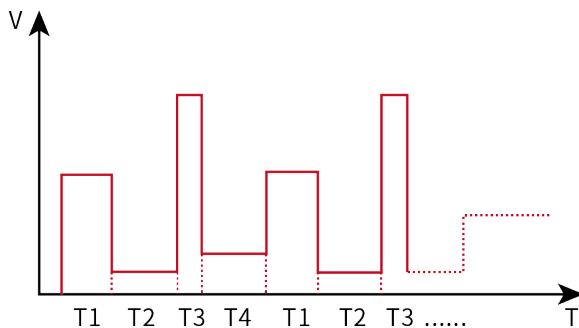

OVP Functions

IT6900B series power supply provides OVP function. The over voltage protection point of the power supply can be set via the keys on the panel. Once power supply is protected (OVP), the output will be off immediately and "OVP" indicator light will be lit, the VFD display "OVER VOLT".



Separate Local key can quickly switch to panel operation mode from PC operation mode

Built-in DVM

IT6900B provides a built-in digital meter which can measure DC volts in a range from 0.001V to 61.000V. The voltage value is displayed on the left bottom field of the display.

Timer Function

IT6900B series supports output timer function, in ON mode, the indicator light "Timer" will be lit on the VFD screen. When output of power supply is opened, timer will begin to work, after reaching the definite time, output will be off automatically. Timing output time range is 0.1s~99999.9s.

Optional external analog interface

The rear panel DB9 analog interface is connected via cable and external DB9 socket board. The corresponding pin on the DB9 socket board is added 0~10V voltage to simulate the voltage or current output from 0 to full-scale.

IT9000 PC software

IT6900B series has built-in RS232, USB, RS485, and provides free IT9000 series software. Using PC software, IT6900B can easily remote control, set voltage and current, record storage data, programming, and test automatically.

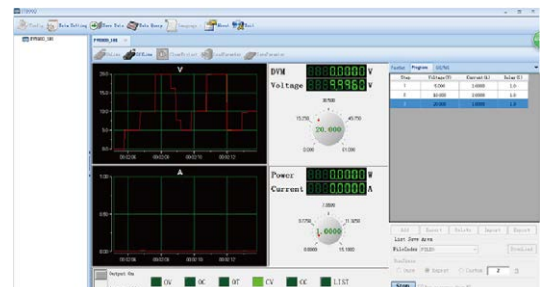

IT6800A/B Single Channel Programmable DC Power Supply



IT6800 single channel programmable DC power supply (180W-216W) supports resolution 1mV/0.1mA. Users can adjust the voltage/current step value by pressing the left and right keys to move the cursor and program on the front panel. IT6800 supports OVP/OTP protection and timer function. Built-in RS232 and USB communication interfaces offer the user convenient experience.

Applications

Laboratory testing, production testing, maintenance testing

Feature

- Support panel programming, numeric keypad operation
- High accuracy and resolution 1mV/0.1mA
- Outputs according to the programmed voltage and current values
- Adjust the voltage and current via knob
- Lower ripple and noise
- Remote sense
- Built-in RS232 / USB/ GPIB interface *1
- Intelligent fan control, save energy and reduce noise

*1Built-in GPIB is available with IT6800B series only

Model	Voltage	Current	Power	Interface
IT6831A	18V	10A	180W	USB/RS232
IT6832A	32V	6A	192W	USB/RS232
IT6832B	32V	6A	192W	USB/RS232/GPIB
IT6833A	72V	3A	216W	USB/RS232
IT6833B	72V	3A	216W	USB/RS232/GPIB
IT6835A	50V	4A	200W	USB/RS232
IT6835B	50V	4A	200W	USB/RS232/GPIB

*IT6800A single channel series is standard model, IT6800B single channel series is optional if you need GPIB interface.

Support panel programming function (List)

IT6800A/B Series Single Channel Programmable DC Power Supply generates a variety of output change sequences by sequentially operating each single step value and time. The parameters in the sequence include time unit, single step voltage, single step current, single step time, and the next step, loop steps, saving files, and so on. After the sequential operation is completed, when a trigger signal is received, the power supply will be turned on until the sequence operation is completed or receive another trigger signal again.

Output timer

IT6800A/B series supports Output timer function, users can start this function in the Menu and set the time. The timer starts working when the unit is powered on. The unit will automatically turn off the output when the set time is due. Timing time setting range 0.1 ~ 9999.9S or 0.1 ~ 9999.9M.



CV/ CC automatic conversion function

With this function, the power supply can be operated continuously from constant voltage mode to constant current mode caused by the load changes

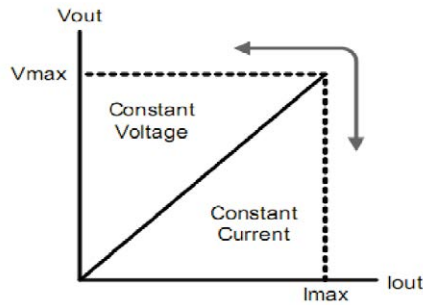

Remote sense function

In order to avoid the voltage drop caused by the length of the wire connecting with the load, the remote sense allows measuring directly on the terminal of DUT to improve the measurement accuracy. S +, S- are the remote sense terminals, +, - refers to the output positive and negative terminals. When using the remote sense function, it is necessary to disconnect the wires connected to the "+, -" terminals and lead S +, S- to the DUT.

IT6800A/B Dimension figure

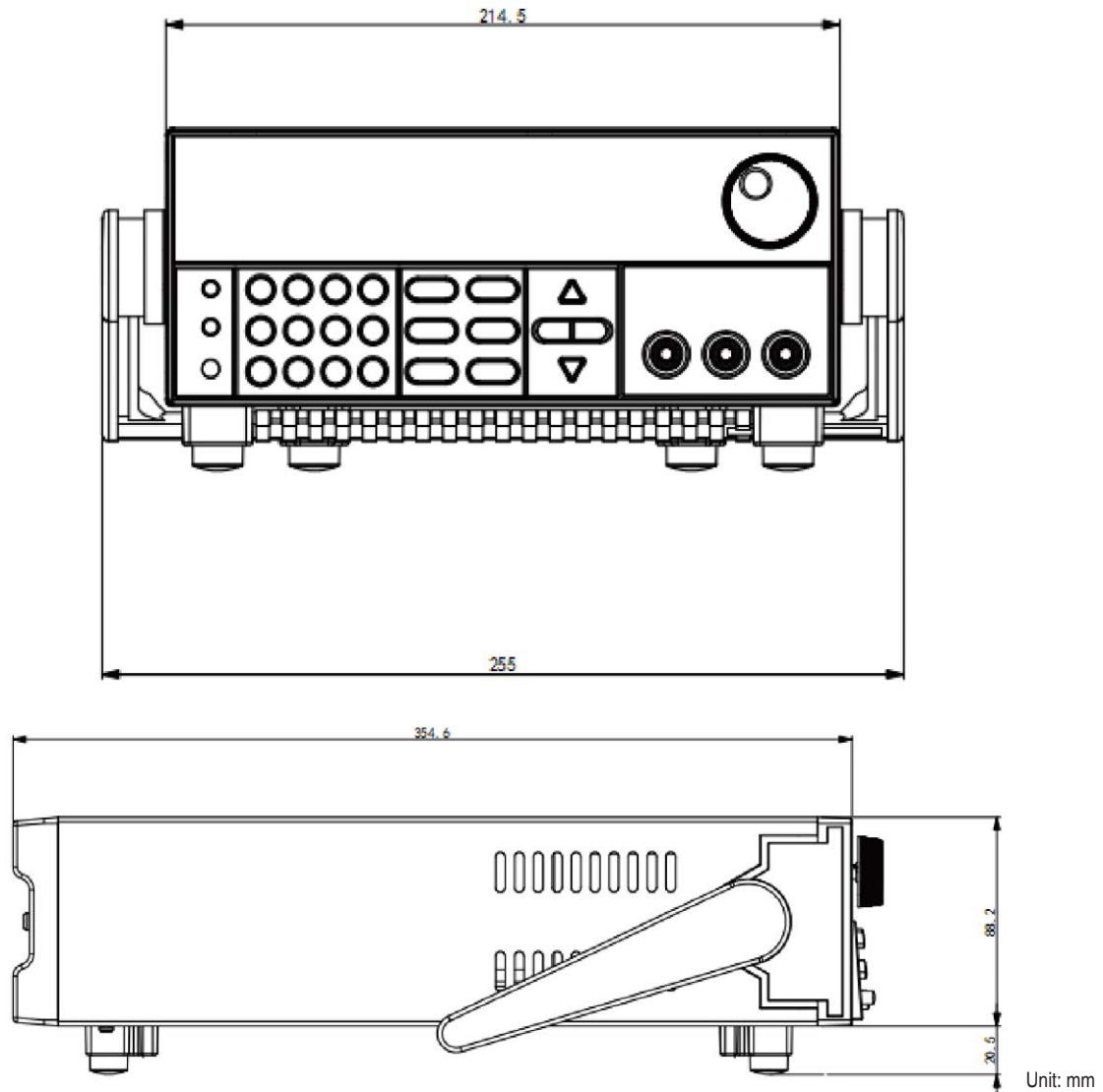

IT6700H High Voltage Wide Range Programmable DC Power Supply



IT6700H high voltage DC power supply support maximum output power 3000W, voltage up to 1200V. IT6700H series provide list mode, built-in RS232 / USB communication interfaces, rich SCPI protocol to facilitate the configuration of a variety of intelligent test platforms.

Applications

Battery fluctuation simulation test, battery charger, high voltage ultra-high speed diode, electrolytic capacitor, electromechanical control field and ATE test system

Feature

- Voltage up to 1200V
- VFD display
- High voltage high current models optional
- Output control via ON/OFF switch
- Safety terminal
- List mode, editable waveforms of voltage and current
- Remote sense
- Built-in RS232/USB *1

*1: IT6722 is with GPIB interface.

*2: For any GPIB interface option request, check with ITECH for availability.

Battery fluctuation simulation test

Battery charging needs high-precision voltage and stable current output to simulate the battery charge and discharge process. IT6700H series can accurately describes the battery charge and discharge process, which is applied in areas need high voltage and low flow direct current, such as battery fluctuation simulation tests, battery chargers, high voltage ultra-high speed diodes, electrolytic capacitors, electromechanical control, and ATE test systems, etc.

Model	Voltage	Current	Power	Size
IT6722	80V	20A	400W	1/2 2U
IT6722A	80V	20A	400W	1/2 2U
IT6723	80V	40A	850W	1/2 2U
IT6723B	150V	20A	850W	1/2 2U
IT6723C	32V	110A	850W	1/2 2U
IT6723G	600V	5A	850W	1/2 2U
IT6723H	300V	10A	850W	1/2 2U
IT6724	80V	40A	1500W	1/2 2U
IT6724B	150V	20A	1500W	1/2 2U
IT6724C	32V	110A	1500W	1/2 2U
IT6724G	600V	5A	1500W	1/2 2U
IT6724H	300V	10A	1500W	1/2 2U
IT6726B	160V	40A	3kW	2U
IT6726C	32V	220A	3kW	2U
IT6726G	600V	10A	3kW	2U
IT6726H	300V	20A	3kW	2U
IT6726V	1200V	5A	3kW	2U

Small size abundant functions, more flexible

IT6700H is with small size, up to 3000W power with only 2U half rack. It can be placed in the standard cabinet. Even for benchtop usage, it saves much space.



Voltage up to 1200V, reasonable design makes high voltage test more secure

IT6700H series supports voltage up to 1200V. High voltage is the basic requirement to the power supply in the fields of LED, battery, DC / DC converters and other industries. Except for mentioned industries above, IT6700H high voltage DC power supply series can also meet ultra-high voltage requirements of the special tests. Engineers always have concerns on the safety of high voltage testing. ITECH is with the design of security terminals and other details to ensure the safety of the test.

Ultra wide range design

The maximum power is not the maximum voltage multiplied by the maximum current. Take one of the models as an example, IT6726H maximum power is 3000W, the maximum voltage and current reach 300V and 20A, a model can replace 2 units or more general power supplies.

IT6722/IT6722ADimension figure

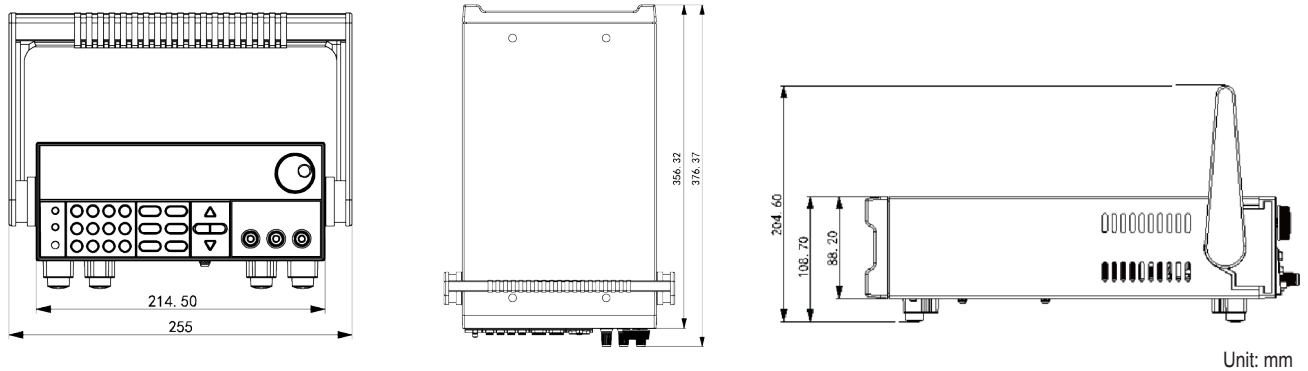

IT6723H/IT6724H/T6723GDimension figure

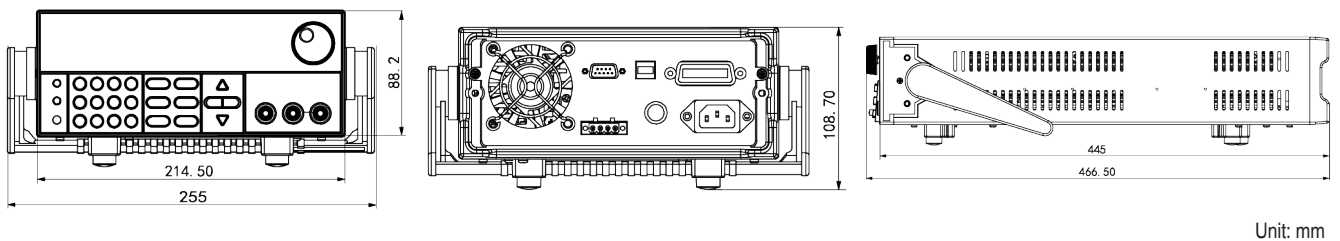

IT6100B High Accuracy Programmable DC Power Supply



Applications

Aerospace power module testing, circuit board testing, medical equipment testing, electronic rectifier testing, etc.

Feature

- Output linear adjustment, high speed, reliable, low noise
- High accuracy and resolution
- Ultrafast voltage rise slew rate
- Built-in 5½ digit voltmeter and milliohmmeter
- Memory capacity: 100 groups
- List mode
- Timer function (0.01~60000S)
- Remote sense, compensate line voltage
- Built-in RS232/USB interfaces, support SCPI protocol *1

*1:For any GPIB interface option request , check with ITECH for availability.

Model	Voltage	Current	Power	Size
IT6121B	20V	5A	100W	1/2 2U
IT6122B	30V	3A	96W	1/2 2U
IT6123B	72V	1.2A	86W	1/2 2U
IT6132B	30V	5A	150W	1/2 2U
IT6133B	60V	2.5A	150W	1/2 2U
IT6162B	20V	50A	1000W	2U
IT6164B	30V/60V	40A/20A	1200W	2U

IT6100B series (86 ~ 1200W) high speed high precision programmable DC power supply is with ultra-fast voltage rising slew rate, resolution up to 0.1mV / 0.01mA, the latest output waveform priority mode allows rising waveform of voltage or current is generated with high-speed and no overshoot, which is widely used in aerospace power modules and other high-precision tests. IT6100B has built-in USB / RS232 communication interfaces and the panel supports List programming, which can provide multi-purpose solution according to customer design and testing demands, easy to use.

Ultrafast voltage rise speed

Comparing with general high speed power supplies, IT6100B series power supplies reduce the ripple and noise to the lowest level. The ultrafast voltage rise speed suits for all high speed and precise tests.



Digital voltage milliohmmeter

IT6100B series has built-in precision digital voltage ohmmeter

Digital ohmmeter: Provide four-wire system to measure resistance, within range: 0 ~ 1KΩ

Digital voltmeter: Built-in 5½ voltmeter is provided to measure the external voltage within range: 0 ~ 40V

IT6100 High Performance Programmable DC Power Supply



Applications

Aerospace power module testing, circuit board testing, medical equipment testing, electronic rectifier testing, etc.

Feature

- Linear programmable power supply
- High-light VFD display
- Lower ripple and lower noise
- Built-in 5 1/2 digital voltmeter
- Support SCPI communication protocol
- Optional USB/RS232 interfaces
- High accuracy and high resolution
- PC monitoring software
- List mode operation, change output voltage and current quickly
- Suitable for 19" standard rack installation

Model	Voltage	Current	Power	Size
IT6151	5.2V	60A	312W	2U
IT6152	20V	27A	540W	2U
IT6153	30V	18A	540W	2U
IT6154	60V	9A	540W	2U

IT6100 series assure you accurate measurements with 0.1mV/0.1mA high resolution and high accuracy. With high-speed List mode output and voltage rise speed up to 20ms, it can independently edit and perform the default voltage waveform to meet the high-speed test needs. IT6100 series has built-in 5 1/2 digital voltmeter and milliohm meter, which can measure additional signals. IT6100 series supports SCPI communication protocol, USB/RS232 interfaces are optional for customers.

IT6100 series power supply is designed to meet the test requirements that general supplies can not achieve. High-speed and high-precision features make production line capacity greatly improved, different from the conventional high speed power supply, IT6100 ensures low ripple and noise while meeting the high speed requirements.

Compared to the conventional power supply, IT6100 provides a lot of advanced and useful functions, including List mode output, built-in 5 digits voltmeter, ohmmeter and other functions.

Built-in precision voltage Ohmmeter 0.1mV / 0.1mA, users can measure output voltage and current values easily and accurately without complicated settings.

Using the standard SCPI communication protocol, engineers can use USB or RS232 to do programming control. With 19 inches standard size, IT6100 series power supply is the most convenient DC power supply for laboratory and production line test.

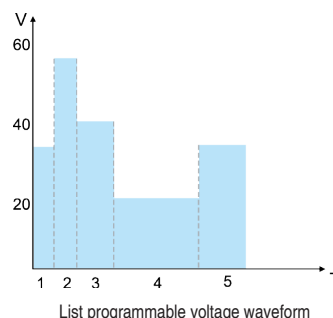

IT6300 High Performance Triple Channels DC power supply

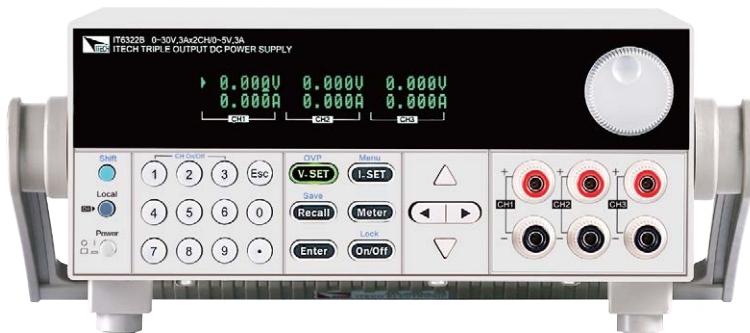

Applications

School/educational laboratories, production lines test, maintenance testing

Feature

- Triple adjustable voltage output, isolated 3 channels
- Serial Parallell Track mede *1
- Display voltage and current measurements continuously from all three outputs
- Small size of 2U half-rack
- VFD display
- Panel function keys with backlight display
- Adjust the digital step value via cursor
- Output switch control
- High accuracy, high resolution and high stability
- Remote measurement function, compensation online voltage drop*2
- Comprehensive protection functions
- Intelligent fan control to reduce noise
- Multi interfaces for choosing, such as USB/RS232/LAN *3

*1: Table 1 for details *2: IT6300A/B/C

*3: For any GPIB interface option request , check with ITECH for availability.

IT6300 series is high-performance programmable triple channels DC power supply, each output voltage and current can be set from 0 to maximum rated output. This series supports series connection, parallel connection and track mode, which offer multi-purpose solutions for customers test. IT6300 series is with high resolution 1mV 1 mA and remote sense function, which make the test more accurate. With built-in standard USB /RS2321 LAN communication interface, IT6300 series greatly enhance the communication speed, and customers also can adjust the digital step value by using the cursor to facilitate the operation.

Track mode (Synchronous output)

CH1 and CH2, CH2 and CH3, or all three channels to be set as track mode, if any one channel parameter changed, the corresponding parameters of the other channels will also change in direct proportion. For example, set up voltage and current of CH1 and CH2 to be CH1: 4V, 1A; CH2:8V, 2A. Set CH1 and CH2 in track mode, in output off and Meter state, VFD is shown below:



*In the setting state, if the voltage of CH1 is set to 2V, the voltage of CH2 will be automatic synchronization to 4V(proportional)

	Specification	Interface	Protection	Channel Setting
IT6322	30V/3A/90W*2CH 5V/3A/15W*1CH	Optional USB/GPIB/RS232	Limited voltage, limited current and OTP	Support serial or parallel connection
IT6322A	30V/3A/90W*2CH 5V/3A/15W*1CH	USB/RS232	OVP,OTP	Support serial, parallel or synchronization
IT6322B	30V/3A/90W*2CH 5V/3A/15W*1CH	USB/GPIB/RS232	OVP,OTP	Support serial, parallel or synchronization
IT6322C	30V/3A/90W*2CH 5V/3A/15W*1CH	USB/LAN	OVP,OTP	Support serial, parallel or synchronization
IT6332A	30V/6A/180W*2CH 5V/3A/15W*1CH	USB/RS232	OVP,OTP	Support serial, parallel or synchronization
IT6332B	30V/6A/180W*2CH 5V/3A/15W*1CH	USB/GPIB/RS232	OVP,OTP	Support serial, parallel or synchronization
IT6332C	30V/6A/180W*2CH 5V/3A/15W*1CH	USB/LAN	OVP,OTP	Support serial, parallel or synchronization
IT6333A	60V/3A/180W*2CH 5V/3A/15W*1CH	USB/RS232	OVP,OTP	Support serial, parallel or synchronization
IT6333B	60V/3A/180W*2CH 5V/3A/15W*1CH	USB/GPIB/RS232	OVP,OTP	Support serial, parallel or synchronization
IT6333C	60V/3A/180W*2CH 5V/3A/15W*1CH	USB/LAN	OVP,OTP	Support serial, parallel or synchronization

IT2800 Graphical Source Measure Unit



Applications

Wafer Die, Analog chip, Passive components, Solar cells, Low power cell, Photodetectors, sensors, Laser light diode

The IT2800 Series are compact and cost-effective bench-top Source Measure Units (SMUs) with the capability to source and measure both voltage and current. These capabilities make the IT2800 Series ideal for a wide variety of IV (current versus voltage) measurement tasks that require both high resolution and accuracy.

The IT2800 Series combine the capabilities of a voltage source, a current source, a voltage meter, a current meter and an ohmmeter (along with the capability to switch easily between these various functions). This ensures the independent measurement of IV characteristic in 4-quadrant. Easily and accurately measure current and voltage using a single instrument without the need to manually change any connections. Besides, the IT2800 Series (SMU) also possess a voltage and current limit feature that allows the user to set limits and to protect devices from damage. Besides, it also provides a broad range of IV measurements for various double or triple terminal devices.

With a current range of 10fA to 10A and a voltage range of 100nV to 1000V, the IT2800 series SMU has capabilities that allow it to perform more than just simple DC and pulsed measurements to prevent errors in measurement results due to the device's own heating. In addition, the IT2800 series SMUs are equipped with high-speed, reliable fiber optic parallel mode, which enables them to work stably and reliably among multiple SMUs and exchange large amounts of data to fulfill a wide variety of test requirements. Excellent Front Panel GUI with 5 inch touch display supports various view modes, to help engineers significantly improve the efficiency of testing.

The IT2800 Series provide best-in-class performance for voltage, current sourcing, excellent precision and various test functions. These capabilities make it suitable for a variety of test applications: discrete semiconductor devices, passive devices, transient suppression devices, laser diodes, TVS, varistors, etc.

Feature

- 5 inch touch display supports both graphical and numerical view modes.
- Combining the capabilities of six devices in one: Voltage Source, Current Source, 6 ½ Digital Multimeter (DCV, DCI, ohms), Battery Simulator, electronic load and Pulse Generator
- Integrating 4-quadrant sourcing & measuring capabilities, and supporting Two-wire & Four-wire measurement
- Resolution up to 10fA/100nV, sampling rate up to 10us.
- Three graphic display modes: Graph View, Scope View and Record View.
- Built-in battery simulator function, suitable for IOT low power precision measurement
- Sweep Capability: Linear/Log/ Pulsed-line AR/ Pulsed-Log and LIST
- Multi-channel and simultaneous operation design, with parallel testing capability
- Built-in resistance, power, and Math measurement features
- With GUARD output function, suitable for low current measurement
- Front USB port used for data storage, screen capture, or test configuration import
- Built-in Digital IO/USB/LAN communication interface

Model	Voltage	Current	Power	Channels
IT2801	±1000V	±1A	±20W	Φ1
IT2805	±200V	±1.5A	±20W	Φ1
IT2806	±200V	±3A DC/ 10A Pulse	±20W	Φ1

Typical Applications

SMUs are ideal for I-V characteristics and high precision measurements for a wide range of applications, such as semiconductor testing, optoelectronic device testing, active/passive component testing, and material characterization. The IT2800 series SMU combines ATE integration with desktop usage requirements. It is an excellent product to meet the diverse testing needs from R&D to production testing and automated manufacturing, from industrial development to university research

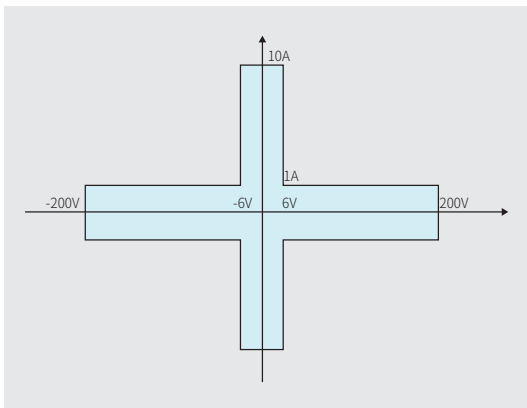

IT2806 200V output characteristic curve (pulse only)

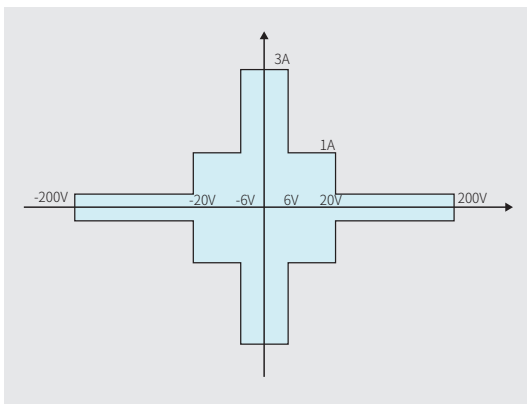

IT2806 200V output characteristic curve (DC or pulse)

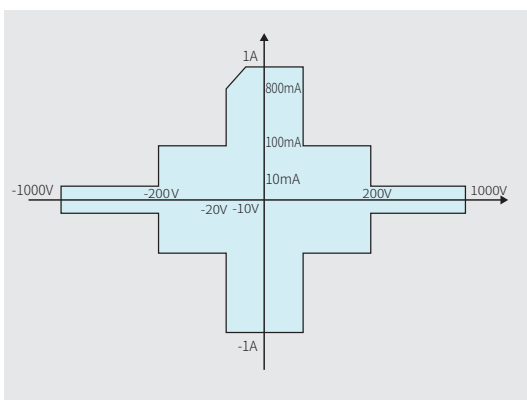

IT2801 1000V output characteristic curve

Applications

E-Batteries and optoelectronic device

Laser light diode/LEDS/AMOLEDs/Mini LEDs, Solar cells, Low power cell, Photodetectors, sensors

Semiconductors, discrete and passive components

Wafer Die, Power LCS (Analog chip, RF chip, Power management chip...), Discrete devices (BJTs, FETs, IGBT, SiC, GaN, Diodes...), Passive components (Varistors, thermistors, switches, resistors...)

Material characterization

Graphene material, Nano materials and other new materials, CNT(carbon nano tube), Giant magnetic resistance (GMR), Organic devices (e-ink)

Multi-channel cascade, easy to achieve parallel testing

The IT2800 series SMU offers multi-channel expansion applications that can connect up to 16 source meter units through fiber ports on the rear backplane to serve as a single, tightly synchronized, multi-channel system. Each channel instrument can run its own independent test sequence to achieve a fully multi-thread test which can meet advanced semiconductor test research as well as batch production line test applications.

Six in one high precision SMU, reduce your test cost

Performing IV measurements with conventional instruments such as voltage/current sources, pulse generator, high precision voltage/current meters, etc. is complicated and costly. It takes up limited test bench space and requires engineers control and synchronize programming of multiple devices to perform an accurate measurement.

The IT2800 series SMU provides engineers with an economical and efficient solution. It integrates different source and measurement capabilities into one compact form factor of 1/2 2U size, which can accurately source and measure voltage and current. It combine the capabilities of six devices including:

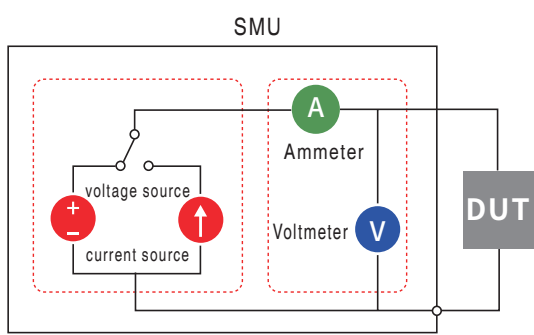
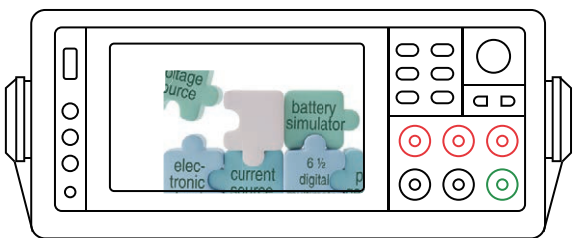

Intuitive graphical display, fast access to product features

The IT2800's front panel has many features that improve the speed of interactive use, user friendliness and ease of operation. These include a 5 inch color LCD display, a USB2.0 memory I/O port, a rotating navigation button, a trigger button, function keys and popular banana jack.

The USB2.0 memory port supports easy data storing, test configuration file import and system upgrade. The IT2800 Series supports both graphical and numerical test results view modes. The intuitive graph view, scope view and record view greatly improves the productivity of bench-top tests and IV characteristic analysis.

Graph view: Graph View displays measurement results on XY graphs (such as I-V and V-t curves) on up to 2 channels. This is useful for quick evaluation of device characteristics, especially those obtained from sweep measurements.

Scope view: Scope view draws I-t or V-t curves in real time during the test. It can capture and export up to 600,000 data points. This function is independent of other functions and can be run simultaneously. In Scope view mode, the sampling rate is up to 100,000 points per second (10us), which facilitates the tester to monitor low frequency transient signals.

Record view: Record view allows the user to view historical waveforms and table data over a period of time. The minimum sampling time interval is 100US, and up to 1 million points of data can be recorded. It also supports exporting to spreadsheets (.csv) for further analysis, greatly improving the efficiency of testing and debugging.



Standard and LIST sweep capabilities

IT2800 Series features standard and LIST sweep capabilities. Under standard sweep mode, it supports parameters such as linear and logarithmic modes, single and double sweep functions and constant and pulsed sweep operation. List sweep functions can efficiently perform arbitrary waveform output which is useful when characterizing devices where the test response varies greatly depending upon the applied voltage or current. The user can use Excel import or panel edit to generate sweep curves of any shape with up to 99,999 data points can be import, which is an ideal choice for testing U-I and I-U features.

Limit test, improve the efficiency of batch product sorting

Limit test is to make pass or fail judgment on measurement data or mathematical operation result data, which are obtained by the channel. A maximum of 12 limits (LIMIT1 to LIMIT12) can be defined. Each limit test status corresponds to 12 Digital I/O ports. When the test passes or fails, the corresponding Digital IO will output pulse signals to implement sorting or grading of products in the production line.

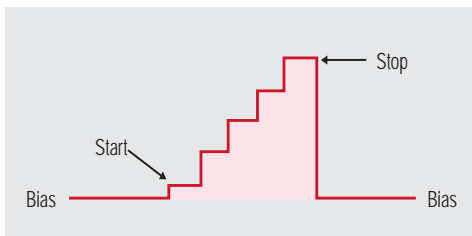

Linear staircase sweep

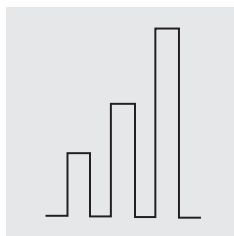

Pulsed linear sweep

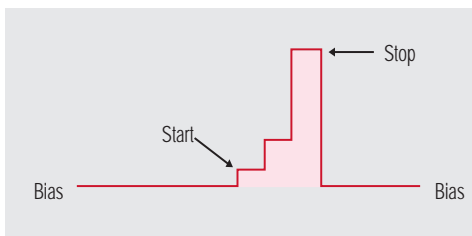

Logarithmic staircase sweep

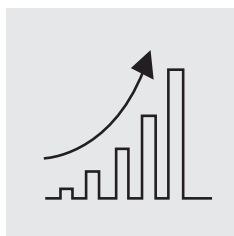

Pulsed logarithmic sweep

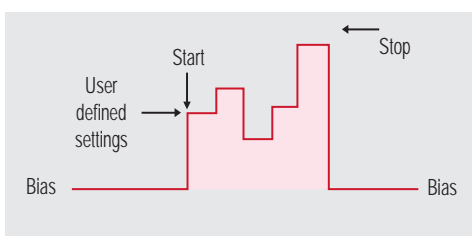

Custom sweep

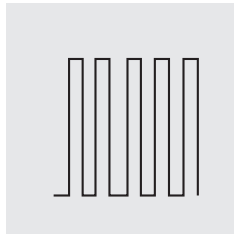

Constant pulsed sweep



Histogram View

Index	Time	data	status
1	0.05s	5.267893V	Fail:Limit5
2	0.10s	5.267988V	Pass
3	0.15s	5.267798V	Pass
4	0.25s	5.267899V	Pass
5	0.30s	5.268082V	Pass
6	0.35s	5.267893V	Pass
7	0.40s	5.267995V	Pass
8	0.45s	5.267996V	Fail:Limit6
9	0.50s	5.267892V	Pass
10	0.55s	5.267893V	Pass

Table View



Battery simulator function enables more accurate analysis of low power consumption

Thanks to the four-quadrant operating characteristics of SMU, the IT2800 Series can not only be used as voltage source, current source, 6 ½ Digital Multimeter, but also built-in professional battery simulator function to help engineers better study the impact of battery characteristics on DUT power consumption and performance reliability.

You can quickly generate battery curves by customizing (SOC-VOC-R) or setting conventional parameters. In addition, the initial SOC state of the battery can be specified arbitrarily, without waiting for charging or discharging like using a real battery, which greatly improves the efficiency of R&D and production testing.

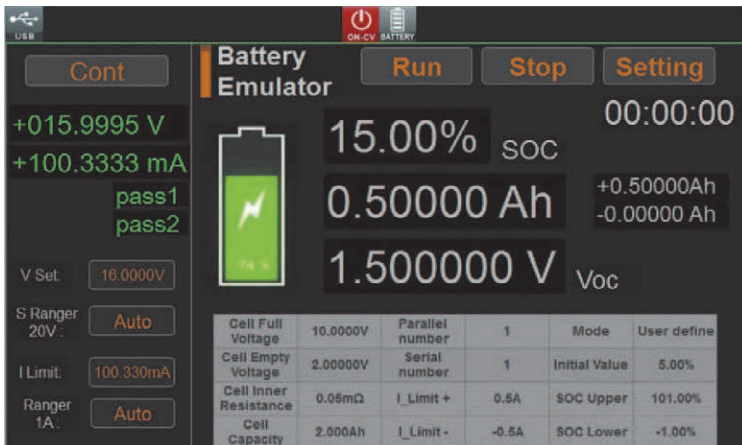

Large cache improves measurement throughput

For testing applications requiring high levels of automation and throughput, the IT2800 series SMU features a large cache. The Measure function can store up to 1 million points of output, and the source-measure measurement can store up to 1 million data points. Engineers can read the cache data in batches at the same time of measurement, so as to realize high-speed data acquisition and reduce the data transmission time in single instruction mode.

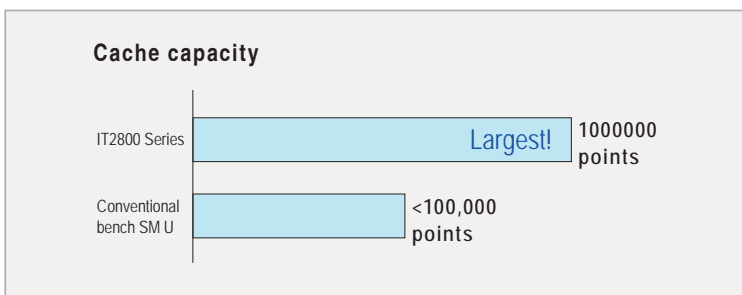

4-wire ohmic measurement permits accurate low resistance measurement

When measuring small resistances the innate cable resistance can create serious measurement error. To solve this, the IT2800 Series supports a 4-wire measurement function. In the 4-wire scheme two of the connectors force current and the other two connectors measure voltage. Since the connectors measuring voltage do not have any current flowing through them, they can accurately sense the actual voltage at the DUT.

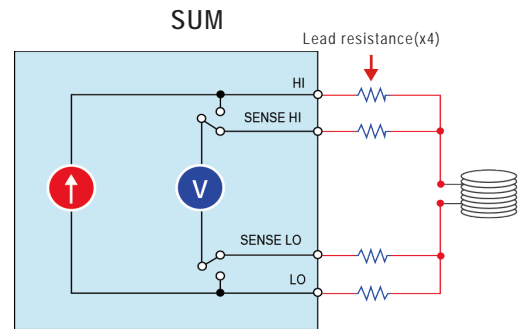

The application case

Resistivity is one of the important parameters of semiconductor materials. The resistivity of a single crystal material is a measure of the resistance of a charged carrier to flow through the material. It is closely related to the performance of semiconductor devices. For example, the breakdown voltage parameters of transistors are directly related to the resistivity of silicon single crystal. Four-probe method is a widely used standard test method, the main advantages of which are easy to operate, high accuracy and no strict requirements on the geometric size of the sample.

Four quadrants and pulse output capability

The IT2800 Series SMU can operate in all four quadrants, where quadrant 1 & 3 are Source mode and quadrant 2 & 4 are Sink mode. The IT2800 Series features a 6 ½ Digital Multimeter with up to 100nV/10fA resolution. The full range of models are available in DC and Pulse output modes. The IT2806 model also offers up to 10A pulse output capability, ideal for testing devices at the semiconductor wafer level, such as VCSEs, laser diodes, and leds, protecting DUTs.

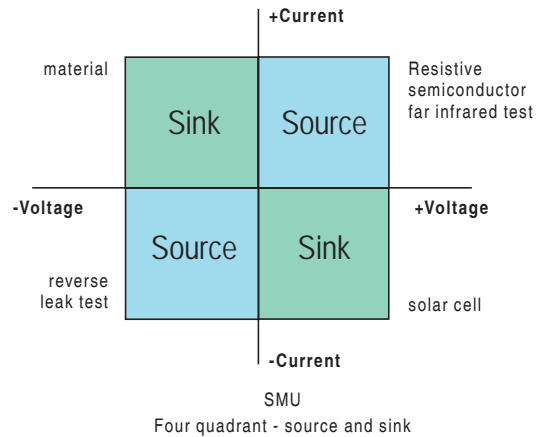

Professional I-V Characteristics Software and Semiconductor Parameters Testing Software

The I-V feature software provides a user-friendly GUI, which can be connected to a PC through the standard USB/LAN interface of the device for fast I-V measurement. The software provides multiple test function modules, including IV characteristic analysis, IV tracer, limit test, battery test and battery simulation, etc.

Semiconductor parameter testing software provides fast and powerful dynamic and static parameter testing solutions for semiconductors. The software presets various types of semiconductor devices, and users can quickly configure SMU by dragging. The graphical UI interface is simple and easy to operate, which accelerates the testing and research process of engineers.

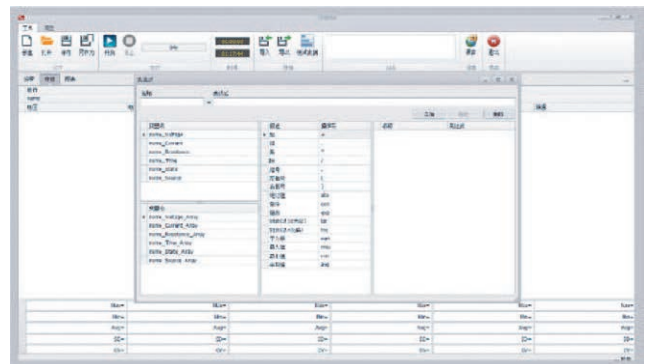
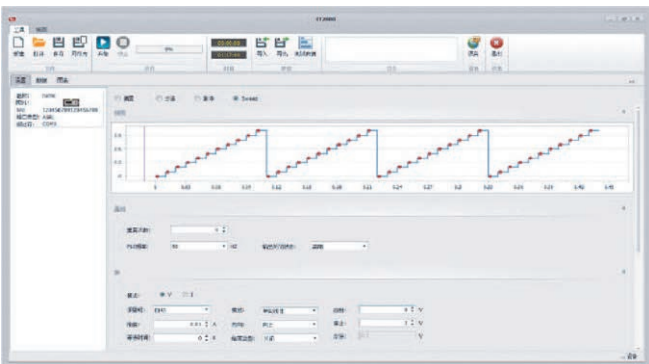
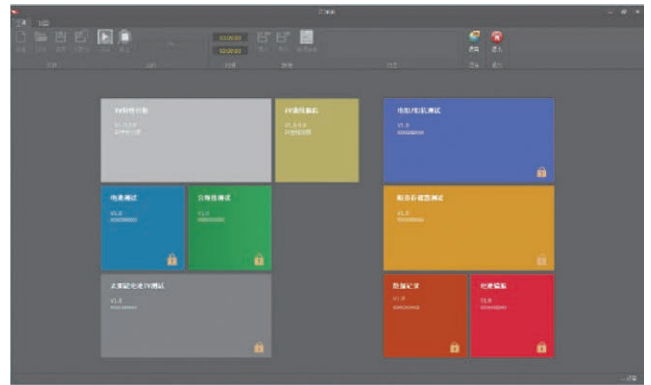

Optional accessories

Model	Description		
IT-E801A	Banana to Triax adapter	applied to IT2805, IT2806	
IT-E802A		applied to IT2801	
IT-E801C-1.5	Low leakage triax cable	length: 1.5m, applied to IT2805, IT2806	
IT-E802C-1.5		length: 1.5m, applied to IT2801	
IT-E176	Optional communication card	GPIB	
IT-E158A	Rack mount kit	rack mount kit for two side-by-side installations in ITECH standard cabinets	
IT-E158B		rack mount kit for two side-by-side installations in non-ITECH standard cabinets	
IT-E158C		rack mount kit for single installation in ITECH standard cabinet	
IT-E158D		rack mount kit for single installation in non-ITECH standard cabinet	
IT-E601	Kelvin(4 wires) testing line	300V pin type lead testing line, applied to IT2805, IT2806 pin(round) type lead	
IT-E601H		1000V pin type lead testing line, applied to IT2801 pin(round) type lead	
IT-E602		300V Large clip type lead applied to IT2805, IT2806 large clip type lead	
IT-E602H		300V Large clip type lead applied to IT2801 large clip type lead	
IT-E603		300V pin type lead testing line, applied to IT2805, IT2806 pin(conical) type lead	
IT-E603H		1000V pin type lead testing line, applied to IT2801 pin(conical) type lead	
IT-E604		pin type lead + Large clip type lead, applied to IT2805, IT2806	
IT-E604H		pin type lead + Large clip type lead, applied to IT2801	
IT-E168		Optical fiber kit	for cascade between units, including fiber optic module and fiber optic harness (0.3m), fiber optic harness(1.5m)
SPS5000		Software	semiconductor parameter testing software (stay tuned)

Kelvin(4 wires) testing line



IT-E601
Pin(round) type lead



IT-E602
Large clip type lead



IT-E603
Pin(conical) type lead

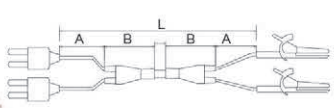

A: 100mm
B: 59.7mm
L: 1219.4mm
DC: 600V

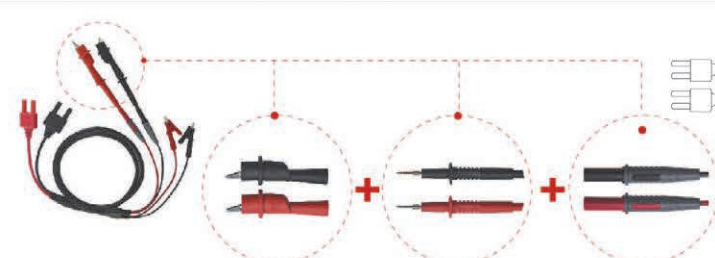

IT-E604
Pin type lead + Large clip type lead

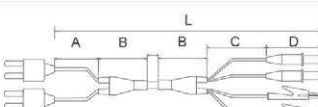

A: 100mm
B: 59.7mm
C: 150mm
D: 67mm
L: 1269.4mm
DC: 600V

Banana to triax adapter

Signal interference or excessive loop leakage current will lower the precision for ultra-low current measurement (below nA level). Therefore, it is necessary to ensure the measurement accuracy of extra low current through wiring protection. It requires to use the special triax cables. The IT2800 SMU provides a wealth of optional accessories banana-to-triax adapters and low-leakage triaxial cable accessories to meet the needs of ultra-low current measurement.

When used together, the guard conductor is at the same potential as the center conductor. Since there is no voltage difference, no current flows from the center conductor to the guard conductor, preventing leakage of current from affecting the test results.

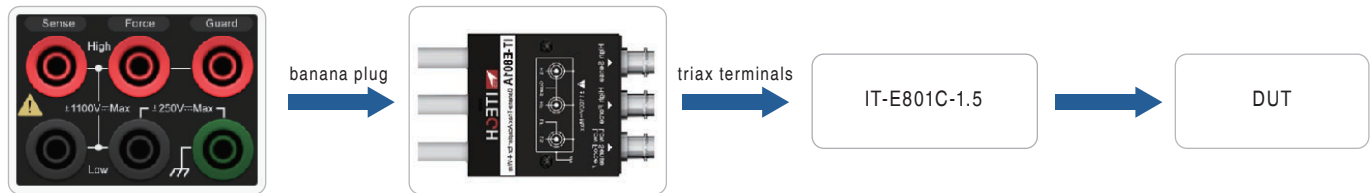

Software	
command	SCPI
communication interfaces	built-in USB/LAN, optional GPIB
control software	PV2800 I-V characteristic curve SPS5000 semiconductor parameter software (charged)
drive	IVI-C、IVI.NET and IVI-COM Driver, LabVIEW Driver

Dimension

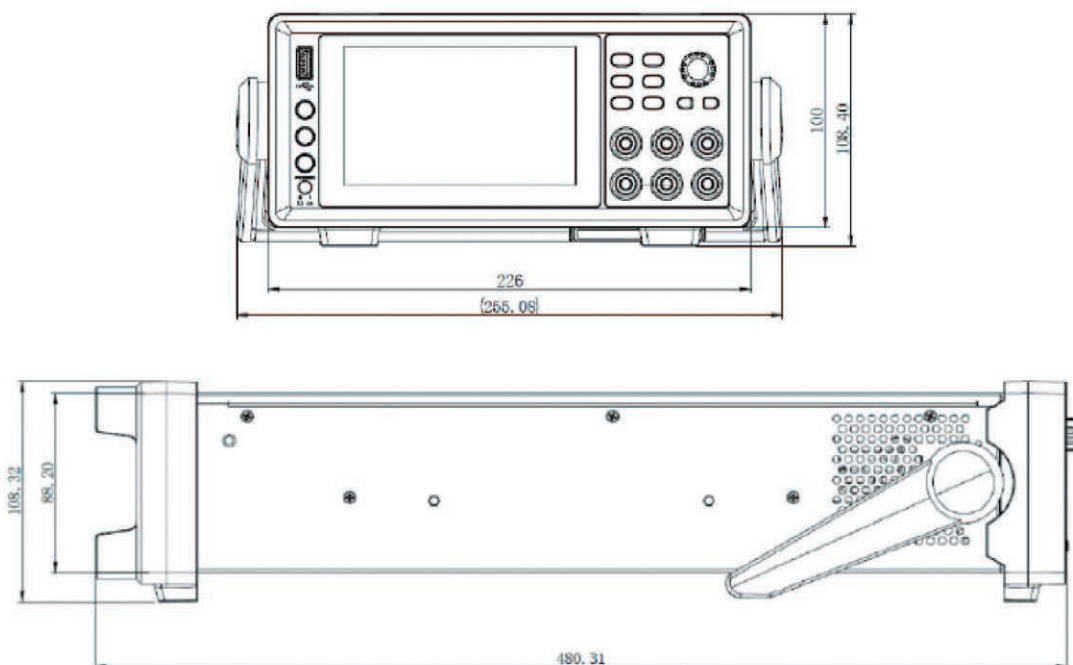



Other Test Equipment

Provide your comprehensive test solution

IT9100 Power Meter

P177~P178

IT9121 power meter can be easily used for measuring the voltage, current, power, frequency, harmonics and other parameters. Whether you need basic power measurement, or more high-end frequency, harmonic and accumulation measurement and other functions, it can provide you with the most stable and reliable, comprehensive and accurate solutions. It is widely applied in test of motors, household appliances, UPS, etc.

IT5100 Battery Internal Resistance Tester

P179~P180

IT5100 series battery internal resistance testers are high in precision, resolution and speed. IT5100 resolution is up to $0.1 \mu\Omega$ and voltage resolution is $10 \mu\text{V}$. IT5100 is with built-in GPIB/USB/LAN interfaces, support SCPI protocol, and can be widely used in various batteries' testing, such as lithium batteries of mobile phone and Unmanned Aerial Vehicles, power batteries, storage batteries and etc.

IT9100 Power Meter



Applications

Motors, household appliances, UPS ,etc.

Feature

- 4.3-inch color LCD (TFT)
- Input range: 1000 Vrms / 50 Arms
- Harmonic measurement function
- The accuracy of voltage and current measurement is up to 0.1%
- Simultaneous measurements of the voltage, current, power, harmonics and other parameters
- The power meter has a function of harmonic measurement, and can be used for measuring up to 50th harmonics *1
- The power meter has rich and powerful accumulation functions, and can be used for measuring electric energy purchased or sold from/to the grid.
- The USB port on front panel is available, the user can save data into external storage
- Standard built-in USB, RS232 and LAN communication interfaces

*1 Optional function for IT9121E

*2 For any GPIB interface option request , check with ITECH for availability.

Model	Voltage	Current	Size
IT9121	600V	20A	1/2 2U
IT9121C	600V	50A	1/2 2U
IT9121H	1000V	20A	1/2 2U

IT9100 power meter can provide a maximum input of 1000 Vrms and 50 Arms and measurement bandwidth of 100 kHz, and can be easily used for measuring the voltage, current, power, frequency, harmonics and other parameters. Whether you need basic power measurement, or more high-end frequency, harmonic and accumulation measurement and other functions, it can provide you with the most stable and reliable, comprehensive and accurate solutions. It is widely applied in test of motors, household appliances, UPS, etc.

Self-define Interface display style

IT9100 power meter provides a 4.3-inch color high-resolution TFT LCD for the user, and real-time values can be displayed with high brightness and remarkable colors even in a dark test environment. In addition, the IT9100 power meter provides multiple interface display styles (View1, View4 and View12). The user can customize the screen display parameter type and display sequence. The humanized design meets engineers' measurement demands in different tests.



Abundant measurement function

IT9100 power meter can measure all AC and DC parameters, including active power, reactive power, apparent power, power factor, voltage, current, frequency, phase difference, etc.. IT9100 provides integrated measurement and up to 50 times of the harmonic measurement function. It is widely used in electronic motors, home appliances PCB board, UPS power supply and other test applications.

Oscilloscope function

IT9100 power meter can display the waveform basing on sampling data. You can choose to display or hide the waveform of the input voltage and current. Oscilloscope function of IT9100 power meter allows users to directly observe the display fluctuations of voltage, current and power trends when testing household appliances performance, and can set the display trends, waveforms, values, histograms. Users can directly capture the waveform and record the value without external oscilloscope via front panel USB storage interface.

Integral measurement function

IT9100 Power Integration feature measures the sold / purchased power with the grid interconnections. IT9100 power meter provides current integration and active power integration (Wh). IT9100 automatically switches the range and performs the integral measurement accurately according to the size of the input level in the mode of buying electricity and selling electricity.

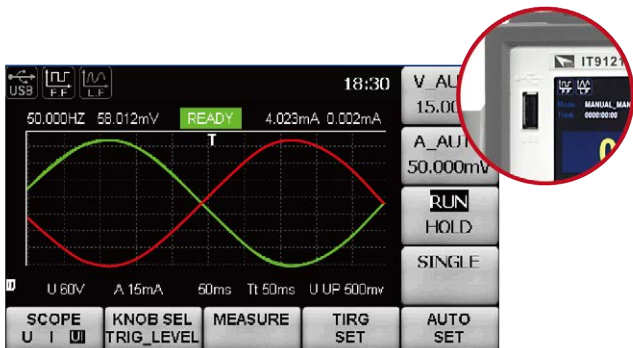

Harmonic Measurement

IT9100 power meter has a bandwidth of 100 kHz, which can realize high-speed harmonic measurement within a wider dynamic range. In the harmonic mode, the voltage, the current, the active power, reactive power and phase of each harmonic and the factor of total harmonic distortion (THD) can be tested.



Line and frequency filtering

IT9100 filters out useless frequency components in the signal, improves the waveform purity, thereby improving the accuracy of the test. Frequency filtering filters out the high frequency components of the interference, making the measured frequency parameters more accurate.



The waveform before turned on line filtering

The waveform after turned on line filtering

Current sensor input

IT9100 power meter provides voltage 0~1000V, the current 0~50A measuring value range. For current measurements above 50A, voltage input type current clamp or current sensor are all adoptable. IT9100 allows users to choose 50mV-2V (EX1) or 2.5V-10V (EXT2) range



IT-E185 Power meter fixture

IT-E185 is an optional accessory , it can facilitate wiring test of IT9100 power meter for users.



IT5100 Battery Internal Resistance Tester



Applications

Lithium batteries, Electric vehicle batteries, Lead-acid batteries, etc.

Feature

- Simultaneous display of resistance and voltage measurements
- Up to 125 measurements/s *1 when simultaneously test voltage and resistance
- 4.3 inch LCD color display
- Voltage measurement: 10 μ V to 1000 V*2
- Automatic or manual testing of measuring ranges
IT5101/IT5101H:3 voltage ranges, 7 resistance ranges
IT5101E:3 voltage ranges, 2 resistance ranges
- Built-in USB, LAN interfaces, support SCPI programming
- Statistics calculation and data storage function
- Comparator function:HI/IN/Lo analysis results
- Zero adjustment function
- AC 4-terminal measurement
- Measuring result alarm

*1. In Ex_fast mode *2. IT5101H

*For any GPIB interface option request, check with ITECH availability.

Model	Voltage	Resistance	Size
IT5101	-300V~+300V	3m Ω ~3000 Ω	2U half rack
IT5101E	-300V~+300V	300m Ω ~3 Ω	2U half rack
IT5101H	-1000V~+1000V	3m Ω ~3000	2U half rack

Measure accuracy, resolution and speed

- High Accuracy
Resistance: $\pm 0.4\% \pm 0.05\% \text{FS}$
Voltage: $\pm 0.01\% \pm 0.01\% \text{FS}$
- High resolution *
Resistance: 0.1 $\mu\Omega$
Voltage: 10 μV
- High speed
Resistance+Voltage simultaneously sampling time < 8 ms
Single sampling time (Resistance or Voltage) < 4 ms

* The resolution is only for IT5101, IT5101E resolution is 10 $\mu\Omega$.

IT5100 series of battery internal resistance testers are high in precision, resolution and speed. IT5100 adopts AC 4-terminal sensing, so it can be more accurate when testing battery internal resistance and voltage. Its resolution is up to 0.1 $\mu\Omega$ and voltage resolution is 10 μV . Through the external U-disk, it can do long-time statistics calculation. Its built-in comparator function can automatically analyze battery's specifications to check standard qualification, pass rate, thus IT5100 is very suitable for battery testing and sorting. IT5100 is with built-in USB/LAN interfaces, support SCPI protocol, and can be widely used in various batteries' testing, such as lithium batteries of mobile phone and unmanned Aerial Vehicles, power batteries, storage batteries and etc.

Applications

- High-voltage battery pack test, e.g. electric vehicles, lithium battery etc.
- Battery module testing
- Large (low-resistance) cell testing
- High-speed mass production testing of button batteries
- UPS inspection
- Internal resistance and voltage testings of lithium batteries
- Deterioration & life assessment of alkaline batteries, lead-acid battery
- Various contact resistance test
- Fuel cell testing
- Resistance (ESR) test of super capacitor



Multifunction ensures measurement accuracy

- **Abnormal measurement inspection**
Detect contact failure and disconnection of test probe, improve the credibility of the measurement
- **Averaging function**
To ensure test stability and reliability, Every 2-16th calculations, there is an averaging
- **AC 4 terminal method**
Impedance measurement uses AC 4-terminal method, the measurement is not affected by the wiring impedance of the test wiring.

Support statistics calculation function

Combined with an external USB disk, IT5101 supports statistical calculation function. The data storage capacity is up to 1000 groups, which greatly simplifies the process and provides convenience to quality control.

Optional accessories

ITECH provides multiple optional accessories for IT5100 series battery testers, including 4 types of testing leads with different probes and zero adjustment board.

Comparator function

- Test resistances & voltage simultaneously
- An alarm signal will be generated when the actual value exceeds the preset (Hi/Lo) range.
- Alternative setting method
- Manual comparator
- Two setting methods
- Comparator function: absolute value comparison and relative value comparison.

IT5101/E provides built-in comparator function, the function can distinguish whether the test parameters are compliant with the related standard and automatically counts the pass/fail rate.

4 types of optional testing leads (600 Vdc max.)



IT-E601 300V
IT-E601H 1000V
pin type lead

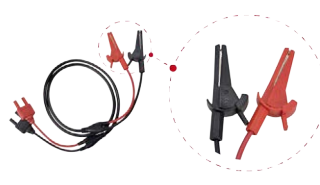

IT-E602 300V
IT-E602H 1000V
large clip type lead



IT-E603 300V
IT-E603H 1000V
pin type lead

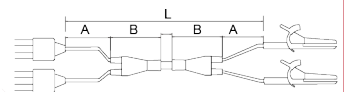

A: 500 mm
B: 59.7 mm
L: 2019.4 mm



IT-E605
zero adjustment board
(For pin testing wire)

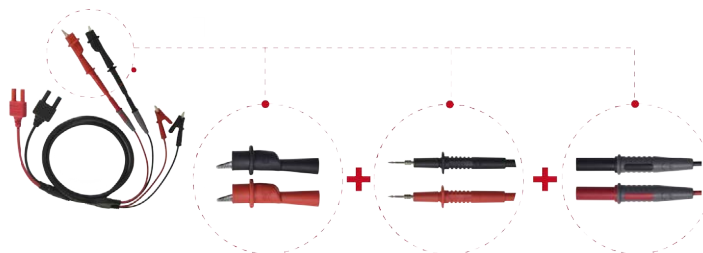

IT-E604 300V
IT-E604H 1000V

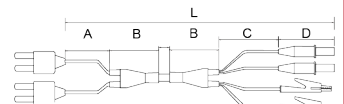

A: 100 mm
B: 59.7 mm
C: 150 mm
D: 67 mm
L: 1269.4 mm

Test System

Provide your a stable and efficient test system

ITS5300 Battery Charge & Discharge Test System

P182~P190

ITS5300 battery charge and discharge test system is designed for a variety of power batteries (lead acid, nickel hydrogen, lithium batteries, super capacitors, hydrogen fuel cells, etc.) for performance testing. Real-time monitoring voltage, resistance and temperature and other parameters of single cell can achieve system' overvoltage, under voltage, overcurrent, overheating protection and the battery pack equalization charge and discharge on single cell, and can simulate electric vehicle' various equivalent conditions on the battery pack.

IT9380 Solar Battery Test Software

P191~P192

IT9380 solar battery test software is the professional software aims to solar IV characteristic. With combination of ITECH programmable electronic loads IT8700/IT8800/IT8900, the solar battery test system is built up. It can test solar battery IV characteristic under kinds of Spectrums and light sources, and supports long time automatic testing.

Automotive Junction Box Test System

P193

Automotive junction box (automotive electrical central controller) integrates the whole car's fuse, circuit breaker, relay and so on. It is the vehicle electronic circuit control center. ITECH automotive junction box test system is established by high performance programmable electronic load, power supply and special-designed IT9360 software.

SAS1000 Solar Array Simulation Software

P194~P199

ITECH latest SAS1000 solar array simulation software, combined with IT6000C, IT6000B or IT6500C high performance high power DC power supply, can accurately simulate solar array I-V curve. It has the characteristics of accurate measurement, high stability and fast response speed . With the built-in EN50530, Sandia, NB/T32004, CGC/GF004, CGC/GF035 SAS module, the solar array simulator enables easy programming on test regulations, materials, Vmp, Pmp parameters, so as to simulate I-V curve characteristic output and generate reports. These benefit much in test of the static & dynamic maximum power tracking performance of photovoltaic inverters.

BSS2000 Battery Simulation Software

P200~P205

The BSS2000/BSS2000 Pro/BSS2000M battery simulating software are products specifically designed for the above test scenarios. On the one hand, it will solve the problem of increasing cost of buying and storage of different types of batteries; On the other hand, the battery simulator can be quickly set to different state of SoC without real charge and discharge process, greatly improve test efficiency.

FCS3000 Fuel Cell Simulation Software

P206~P207

The FCS3000 fuel cell simulation software matched with IT6000C bidirectional DC power supply and IT6000B regenerative power system, can accurately simulate the polarization characteristic curve of the fuel cell stack. The maximum voltage can reach 2250V and the power can be expanded to 1152kW to meet the test requirement of high-power fuel cell simulation.



ITS5300 Battery cell/ Battery module/ Battery Pack BOL Test System

Applications

battery charge / discharge performance test, battery cycle life test, battery capacity test, quality check, production testing, etc.



ITS5300 battery charging discharging test system provides turnkey testing solution from Milliampere-grade single cell to Megawatt battery pack. During charging-discharging life cycle test (BOL Test), it can simulate the real working condition, such as driving cycle, current pulse and self-defined waveform, to realize the comprehensive evaluation of battery life time, energy, and endurance mileage. The system is applicable to new products development, quality analysis/incoming inspection, production test and so on. Modular design provides great flexibility and independence for the test system configuration.

To meet the demand of production line testing in large quantities, ITS5300 can simultaneously test the performance of hundreds of independent battery modules/cells, greatly improving the testing efficiency and production of production line. ITS5300 also provides regenerative test solution, and the regenerative efficiency up to 95%, it solves the problem of high electricity cost caused by high power storage battery or large quantity battery module/cell test. ITS5300 provides comprehensive protection function, not merely hardware itself has over-voltage, over-current, over-temperature, anti-islanding protections, but also the system has optional functions such as emergency stop module, power-off memory function, anti-sparkling and reverse connection protection, under voltage protection etc, so as to effectively ensure the reliability of long-time operation of the system.

The ITS5300 battery test system offers a wealth of test steps and powerful statistical analysis capabilities. The channels can be operated synchronously/independently without affecting each other, and support third-party device control (temperature box or water-cooling system). Powerful statistical analysis function, to assist testers to quickly filter data, efficient completion of battery performance parameters analysis.

Feature

- Modular design, Maximum voltage and power up to 2250V/2MW
- Power regenerative efficiency up to 95%
- Full protection
- High precision measurement, up to 0.02%+0.02%FS
- AC/DC internal resistance test
- Strong scalability, easy to integrate other equipment
- High sampling rate, up to 1ms
- Rich charging and discharging test steps
- Seamless current switching, road conditions simulation
- Data query and statistical analysis functions

Battery Pack Test Solutions

ITS5300 battery pack test system can meet not only the basic but also the complicate testing application items, providing solutions for high-power batteries, such as batteries for EV, aerospace, military defense, energy storage, etc. The system is able to simulate the vehicle driving conditions, do cold cranking test and other self-defined waveforms, and etc. For the battery pack test on the vehicle, the system can simulate the standard charging process between the DC pile and the BMS, providing advanced energy-saving bi-directional regenerative solution.

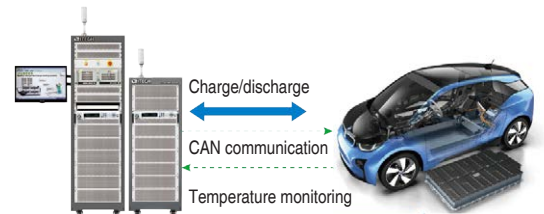

Range of battery pack test

- Voltage: Maximum up to 2250V
- Current: For single unit, up to 2040A

- Measurement accuracy of maximum voltage: $\leq 0.02\% + 0.02\%FS$
- Power: Maximum up to 1152kW
- Ultra-fast sample rate: quickest can be 1ms
- Measurement accuracy of maximum current: $\leq 0.1\% + 0.1\%FS$

*support paralleling for higher current

Features of battery pack test system

- Bidirectional regenerative module of high power density, up to 18kW per single 3U module.
- High energy regenerative efficiency up to 95%.
- Parallel technology of fiber paralleling for higher power.
- Seamless switching between sourcing and sinking.
- Simulation of driving condition waveforms of up to 10,000,000 points.
- BMS message receiving and transmitting.
- Auxiliary power supply and parameters measurement.
- Supporting integration of equipment from 3rd party, equipment such as incubator, water-cooling system.
- Independent control of each channel while running.
- Simulation of DC charging station to do testing of complete vehicle's battery.
- Simulation of HPPC (Hybrid Pulse Power Characteristic)/Cold Cranking current
- Quick data checking and statistics analyzing functions.

Energy-regenerative testing solutions

ITS5300 battery pack test system can be configured with bidirectional regenerative charging and discharging module, the energy could feed back to grid so as to save electricity during the high-power battery testing. Different from the traditional composition, the energy regenerative solution can convert the battery's energy to clean alternative current electricity which can be used for other power-consuming units in the local grid. The electricity cost could be saved in a big way due to this regenerative system. Besides the bidirectional instruments can also save space for cabinet: the testing channels can be doubled in cabinet integration and this help to improve the testing efficiency.

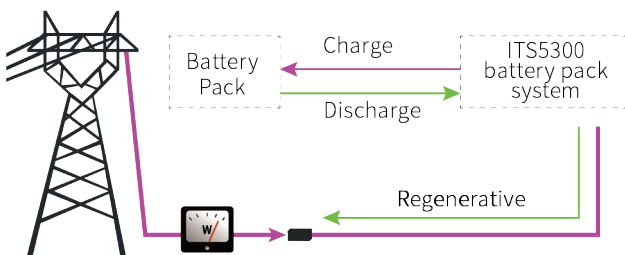

BMS communication function

ITS5300 battery pack test system provides BMS communication function. The message transmitting and receiving can be communicated between the battery test system and BMS, recording all messages so as for further analyzing. The test system can adjust charging and discharging parameters according to BMS requests, can meet cut off conditions give warning messages based on data collecting from BMS, as well as supports DBC files importing.

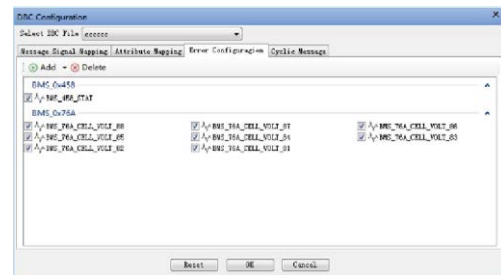

Dynamic working conditions simulation

ITS5300 battery pack test system provides complex dynamic working conditions simulation for EV battery application. The software supports .csv file import, and the user may import 10000000 points current waveform data, simulate electric vehicle starting, braking, accelerating, reducing under different road conditions in cities or suburbs from the process of charging from battery power or reverse charging when brakes. The system can also calculate vehicle mileage to reflect the performance of electric vehicles.

Imported waveform points: 10,000,000
Positive and negative current switching time: seamless switching
Current response time (-90% ~ 90%): <2ms

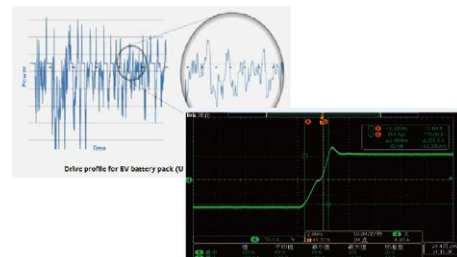

ITS5300 battery pack test system current switching waveform



● Parallel between channels to expand power

ITS5300 high-power battery pack test system is with ultra-high power density, the power of a 27U can reach 144kW. Supports master-slave parallel with different power levels at the same voltage units, and can be switched to work with multiple channels. Very flexible for maximum utilization.

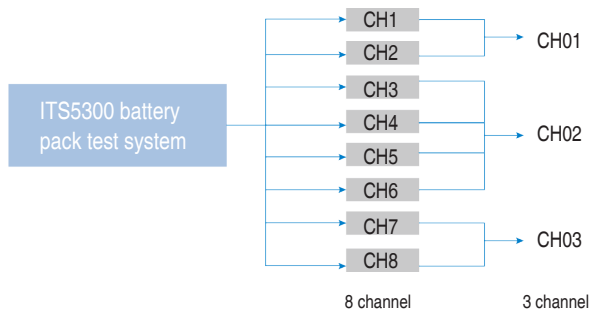

● Simulate charging pile

When the power battery pack is placed in the vehicle for testing, the ITS5300 battery pack test system can simulate the DC charging pile to interact with the BMS, and dynamically adjust charging parameters according to the request of the BMS; or when receiving an error message, our system will stop charging in time. The ITS5300 system supports the import of DBC files. All CAN messages will be recorded when tests end.

● Simulate charging pile

Because the battery characteristics are affected by the ambient temperature, when the temperature is higher, the output energy is larger; otherwise, the output energy is smaller. In the R&D experiment stage, in order to fully verify the temperature characteristics of the battery, place the battery pack in the thermostat cabinet, set the temperature of the thermostat cabinet, and complete the high and low temperature experiments. The ITS5300 battery pack test system can integrate a thermostat or water cooling system according to user needs. The software automatically controls the temperature of the thermostat or starts the water cooling system.

● Simulate charging pile

ITS5300 battery pack test system supports auxiliary measurement function, can monitor the battery pack for additional temperature and voltage with optional temperature logger or multi-channel DVM meter. Temperature logger supports

various types of thermo couples, T, K, B, E, J, N, S, R, C, measuring accuracy: $\pm (0.01\% \text{ of reading} + 0.5) ^\circ\text{C}$.

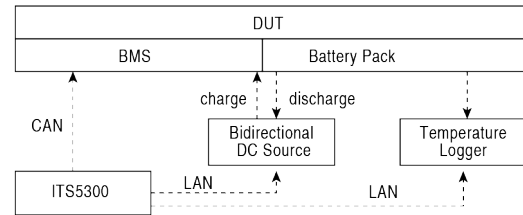

Battery Module Test Solution

ITS5300 battery module test system provides users with two solutions, non-regenerative and regenerative, both can synchronously monitor the voltage and temperature of each cell in the module while testing the performance of the module. For smart 3C battery testing, ITS5300 can directly obtain module parameters by supporting communication between SMBus and battery modules. For power battery module testing, ITS5300 provides complex road conditions simulation, cold-start current pulse test and HPPC test, etc. Furthermore, this software provides rich test steps, powerful curve drawing, data query and statistical analysis functions.

*1 Configure with temperature logger and IR tester

● Battery module test range

- Voltage range: 0~1000V
- Current range: 1200A for stand-alone
- Max. voltage accuracy: $\leq 0.025\% + 0.025\%FS$
- Max. current accuracy: $\leq 0.05\% + 0.1\%FS$
- Ultra-fast sampling rate: 10ms

● Battery module system features

- ACIR and DCIR Test
- HPCE test
- Cycle life test
- Charging and discharging test at different temperatures (room temperature/ high temperature/ low temperature)
- Charging and discharging test at different rate
- Charge retention test

- BMS communication supporting CANBus or SMBus protocol
- HPPC
- Cell temperature / voltage monitoring function in the module

• Cell voltage / temperature monitoring in the battery module

ITS5300 battery module test system provides internal resistance measurement function, combined with temperature logger and internal resistance tester or DVM meter, it can simultaneously monitor the voltage and temperature changes of the unit in the module. And, if the voltage difference exceeds the allowable range, the test will be stopped. ITS5300 temperature logger supports various types of thermocouples, T, K, B, E, J, N, S, R, C, and the accuracy is up to $\pm (0.01\% \text{ of reading} + 0.5) \text{ } ^\circ\text{C}$.

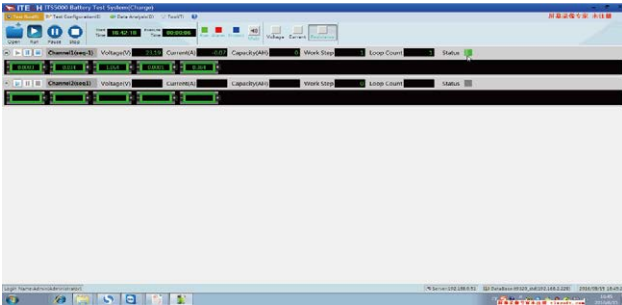

• Multi-channel online operation / parallel extension power

ITS5300 battery module testing system supports hundreds of channel modules to be tested online at the same time. Channels are independent of each other and can be run simultaneously or controlled separately. The module power between channels can be extended by master and slave parallel, PC only needs to communicate with the host. Different test programs can be executed between channels, which improve the application flexibility of the system.

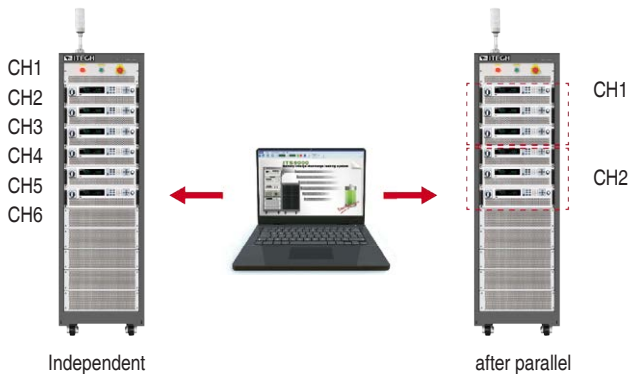

Cell Test Solution

• Cell test range

- Unit voltage range: 0 ~ 10V
- Single current range: 500mA / 10A / 100A / 200A / 400A / 500A / 600A
- Voltage measurement accuracy: <0.1% FS
- Current measurement accuracy: <0.1% FS

• Function and characteristics of single cell system

- Bidirectional energy-feedback test solution
- AC Impedance (ACIR)
- Cycle life test
- Charging and discharging characteristics test at different temperatures (normal temperature / high temperature / low temperature)
- Charge-discharge ability test at different rates
- Self-discharge characteristic test
- Other devices can be integrated: thermostat / water cooling system / DVM meter
- Fast data query and analysis functions

• Cell resistance / capacitance test

Battery cell is the smallest unit of the battery. Selecting a battery cell with a better capacity and internal resistance consistency can ensure stable performance and greater output capacity of the battery module or battery pack after series and parallel connection. Therefore, in the test of cell, resistance and capacitance testing becomes particularly important. ITECH ITS5300 cell test system supports the simultaneous testing of hundreds of channels. While improving the test efficiency of the production line, the system can measure the internal resistance and capacity value of each cell. The internal resistance measurement accuracy is up to $\pm 0.5\% \pm 0.05\% \text{ FS}$.

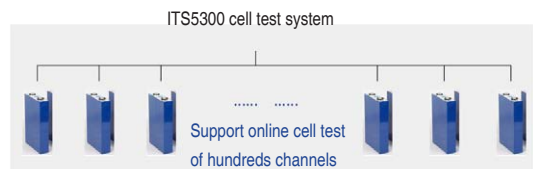

● Ultra-high measurement accuracy

Battery capacity is an important indicator of battery characteristics. The traditional battery capacity is implemented by software sampling and integration. Due to the limited communication speed, the sampling rate can only reach 20ms or even longer. ITS5300 battery test system uses the built-in capacity integration function of the hardware module to improve the V / I measurement accuracy and sampling rate, the sample rate is up to 400 kHz. When the current waveform changes, it can still be accurately sampled and integrated in real time to obtain more accurate capacity parameters for the user.

● Cell test application range

Suitable for various types of batteries and super capacitor testing.

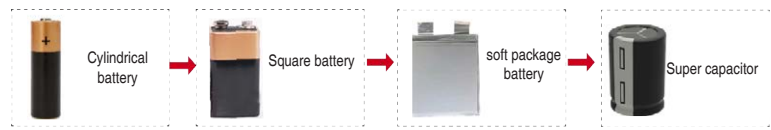

| Functions and Advantages

● Battery DCIR/ACIR test

The internal resistance of the battery is related to the discharge capacity of the battery. The larger the internal resistance, the smaller the charge and discharge rate of the battery, which will easily cause the battery to generate heat. ITECH provides battery AC internal resistance and DC internal resistance measurement functions. The AC internal resistance is matched with a special AC internal resistance tester to apply a 1KHz excitation signal to both ends of the battery to measure the internal resistance of the battery under static conditions. However, under the real condition, it also includes the polarization internal resistance, the impedance of the connection point, etc. The DC resistance test can more directly reflect the resistance value of the battery in continuous application.

● Battery capacity test

Because the battery capacity is affected by the ambient temperature and discharge rate, the capacity test is usually combined with the temperature characteristics and discharge rate. The higher the temperature, the larger the capacity; the larger the discharge rate, the smaller the capacity. ITS5300 system can integrate the control of thermostat, and simulate the environment of normal temperature, high temperature and low temperature. ITS5300 system provides the function of user-defined X-axis and Y-axis parameter categories. You can set the Y-axis as the capacity and the X-axis as the time to obtain the corresponding curve.

discharge characteristics(by rate of discharge)

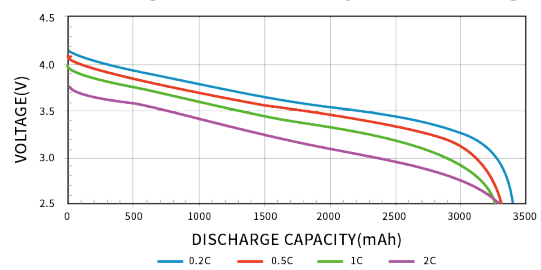

● Battery cycle life test

The battery cycle life test is one of the necessary test items for the battery. When the capacity declines to 80% of the original, the life can be considered to end, and the battery life is generally obtained by cyclic charging and discharging. Speaking of the factors affecting battery life, in addition to temperature and frequency of use, dynamic operating conditions will also accelerate battery aging. ITS5300 provides pulse charge and discharge mode and edit steps according to rich charge, rich discharge curve marked in the ISO12405-4-2018 standard.

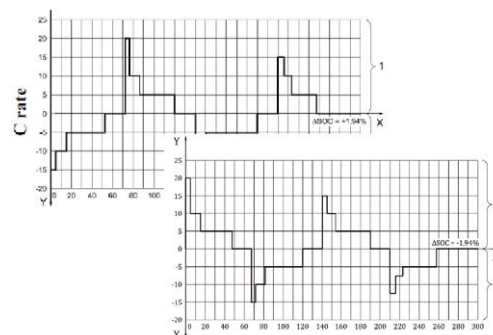

● Coulombic efficiency test

Coulombic efficiency describes the efficiency with which charge (electrons) is transferred in a system facilitating an electrochemical reaction. The closer the discharge charge is to the charge, the higher the utilization rate of the battery. If the ratio is small, it indicates that the technical or other aspects of the battery need to be improved. For batteries with good characteristics, high-precision test equipment is necessary for telling the difference between the charged and discharged charges. ITS5300 presents ultra-high sampling rate and measurement accuracy.

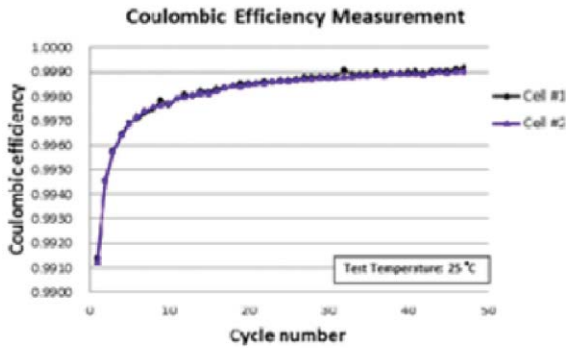

● **HPPC test**

The HPPC test is a very important test in FreedomCar. It is used to test the performance of hybrid and pure electric vehicles. It is a common test item when evaluating battery systems / modules or single cells. The main test purpose of HPPC is to establish the relationship between discharge depth and power within the battery voltage range. The second is to use the voltage and current curve to establish a function of the discharge depth, conductive resistance and polarization resistance. Then it can evaluate power degradation during life testing by the resistance measurement results. It is a detection method for fully analyzing power batteries. ITS5300 supports users to edit discharge pulse and feedback pulse value according to HPPC curve.

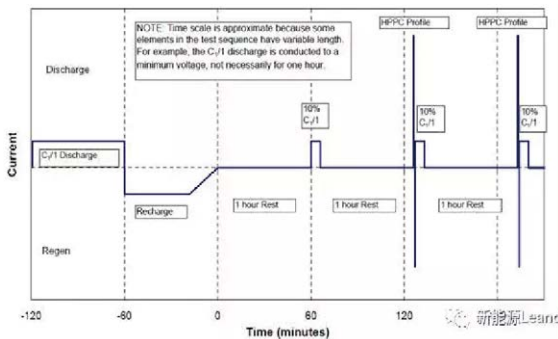

● **Battery overcharge / over discharge endurance test**

For a sealed secondary battery, in the case of overcharging and over discharging, gas will quickly accumulate in the sealed container, and the internal pressure will rise rapidly, which will easily cause the battery to explode. So overcharge and over discharge are important test items to test the safety performance of the battery. Under a certain degree of overcharge, the shape of the battery should not change and catch fire. In order to ensure the safety of the battery, it should be specified of the battery's charging limit voltage, charging upper limit voltage, lower discharging limit voltage, maximum charging current and recommended charging current.

● **Equilibrium charge and discharge test**

The differences in the manufacturing and use processes will cause inconsistencies in the cells inside the battery, which are manifested in terms of cell capacity, internal resistance, and charge and discharge efficiency. In order to avoid the life and capacity loss of the overall battery pack caused by degradation of individual performance, BMS generally has a balanced function. At present, the balancing strategy of each BMS is different. The individual cells can be balanced with each other or an energy-consuming method may also be adopted. A resistor is connected to the back end of each cell to consume the power of the cell with a higher power. ITS5300 can accept the balanced start and stop signals of the BMS during the charging and discharging process. Adopting balancing operation of the BMS during the charging and discharging can prevent large differences in battery cells and extend battery life.

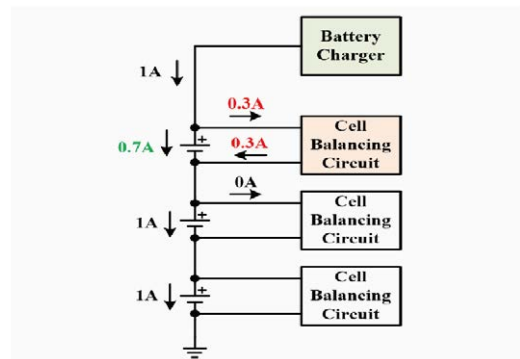

● **Vehicle power battery pack test**

When the power battery pack is placed in the vehicle for testing, the battery charging and discharging system needs to simulate the DC charging pile to interact with the BMS. It can dynamically adjust the charging parameters according to the request of the BMS or stop charging when receiving wrong messages. The ITS5300 system supports the import of DBC files, and after the operation ends, all CAN messages sent and received during the process are recorded.

● Dynamic roading conditions simulation test

ITS5300 provides comprehensive dynamic operating simulation functions for EV battery applications. Users can import 10,000,000 points of current waveform data to simulate the process from battery consumption or reverse charging during starting, braking, acceleration and deceleration of an EV under different road conditions in cities or suburbs. The .csv file import is available. ITS5300 software can also help to calculate vehicle mileage for vehicle manufacturers which reflects the performance of electric vehicles more directly.

Protection

● Acousto-optic emergency stop

The ITS5300 battery cell / module / battery pack test system provides an acousto-optic emergency stop protection device. When an abnormal situation occurs, the emergency stop button can be used to quickly cut off the output and ensure that the equipment is powered off reliably. The cabinet is equipped with three-color lights, which indicate different operating states through red / yellow / green lights, which is convenient to identify the status of the system from a long distance and provide audible alarm.

● Power-off memory protection

Battery performance verification is often a long-term test process. The power-off memory protection module is designed and developed specifically for long-term testing. It can effectively ensure that the long-term test data is protected from abnormal power failures or computer crashes. After the system resumes normal operation, the program continues to execute the next steps, avoiding repeated testing and improving the safety and reliability of the experiment.

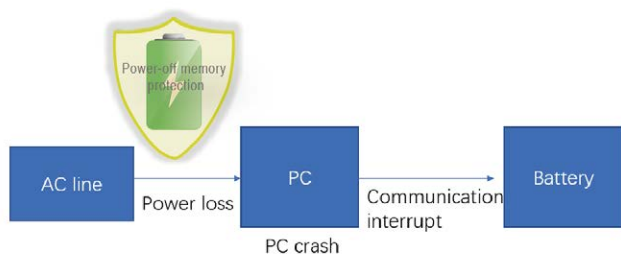

● Anti-reverse/anti-spark protection

Anti-reverse anti-spark module is a functional module specially designed to improve safe wiring and reliable power-on. It prevents from the fire phenomenon caused by the suddenly battery charging to internal capacitor of the device during the wiring. And also prevent the battery from being reversely connected to both ends of the device and result in equipment damage.

● User rights management function

The ITS5300 test system can set different operation permissions for people in charge of quality, R&D, and production through the user permission setting function. So it can prevent system programs from being arbitrarily modified or artificially stopped abnormally and ensure the reliability and security of the system.

● Comprehensive charge and discharge protection

In the battery BOL test, to avoid overcharging and over discharging of the battery, it is necessary to monitor the status of the single cell and the entire battery pack in real time, and when the certain conditions are reached, the circuit is cut off in time to protect the battery. The ITS5300 system provides comprehensive protection, including over and under voltage of each channel and cell, pressure difference of cell, over temperature, over power, etc. Users can customize single or multiple protection settings based on battery specifications.

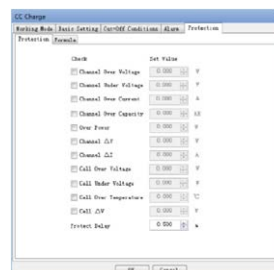

● Anti-islanding protection (regenerative system)

For the energy regenerative battery system solution, the instrument has an anti-islanding protection function to prevent itself from keeping feeding back energy to the grid in the event of a mains power outage, causing unnecessary injury. The energy regenerative system provides pure AC power(harmonics<5%). The feedback energy can be used as power supply for other equipment in the plant, good for saving electricity costs, especially for high power applications where a battery pack or a large number of cells are tested simultaneously.

Test System

Function Introduction

ITS5300 battery test system adopts all-new software structure that allows users to quickly edit test programs without any language programming basics. And, the software provides rich test steps, ultra-fast sampling rates, and powerful report analysis functions, which not only meet various battery test requirements, but also help improve battery process and trace quality problems in the later stages of testing. ITS5300 test system software has strong scalability, and reserves interfaces for integrating third-party devices, such as temperature boxes and water cooling systems.

ITECH System Software Advantages

- No programming basics required, friendly and simple interface
- Rich charge and discharge work steps
- Comprehensive protection functions and cut-off conditions
- Ultra-fast sampling rate: up to 1ms
- Quick copy of test procedures between channels
- Independent or synchronous operation control between channels
- Powerful data query / statistical analysis function
- Fault alarm / fault information recording function
- BMS interaction & message recording function
- User rights management function

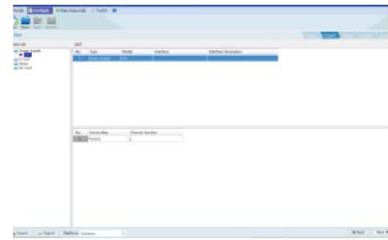

Configuration interface



Real-time display

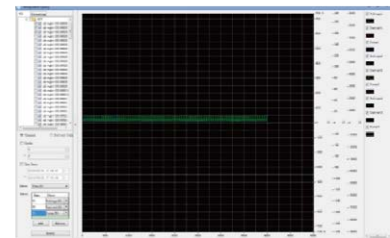

Curve described



Main interface

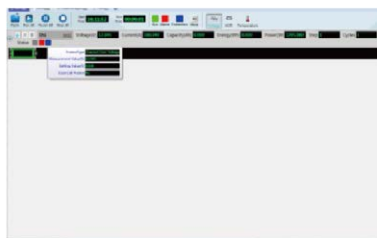

Operation interface

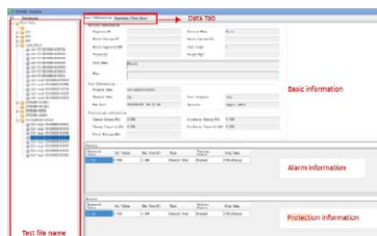

Report interface

Rich Test Work Steps

- Test work steps: CC / CV / CP / CC-CV / CP-CV / CR / Reset / Pulse / DCIR / ACIR / Waveform etc. *
- Cut-off conditions: CAN message / rate of change / expression / Conventional cut-off conditions (cell voltage, cell voltage difference, time, capacity, current, channel voltage)
- Unlimited loop cycle times, unlimited numbers of loop nesting
- Goto
- Reset / stand-by process
- Battery pre-judgment

*Depending on the specific configuration



Test purpose-battery performance evaluation

The ITS5300 battery test system provides users with data query and export functions, records battery information within the full test period, such as channel voltage / current / power / capacity / energy, etc., and can also display a certain process step or cell data.

- File export in .csv format
- Curve zoom, recording the whole time period or certain running curve
- Data screening, running time / test steps / cycle times...

• Statistical analysis, improve battery performance analysis efficiency

Statistical analysis is a function designed to help engineers to quickly complete the analysis of battery performance from the huge original data base. Through flexible data screening and curve configuration, the software will automatically calculate a series of key data such as maximum and minimum capacity, etc. Users can have higher efficiency on evaluating the capacity attenuation ratio and voltage attenuation ratio of batteries.

• Fault recording, help to find out the cause of battery abnormality

Different from the traditional battery test software, the ITS5300 battery test system can not only complete safe and reliable automatic control with full protection, but also have a recording function

• Multi-curve display, directly reflects the trend of battery performance changes

ITS5300 provides powerful curve editing functions. Users can customize the parameters of the horizontal and vertical axes to obtain different battery curves, such as C-t, CV, V-t, and so on. The operation is very flexible. More importantly, ITS5300 provides a vertical comparison and analysis function of battery performance curves, which can put the curves at different temperatures or different discharge depths in a chart, so that users can observe more directly how the battery performance is affected by external conditions.

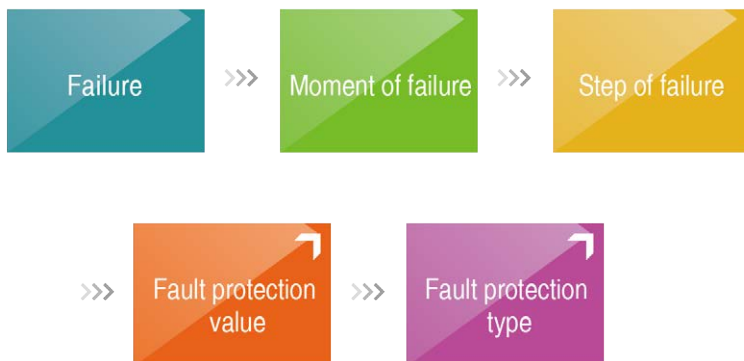

IT9380 Solar Battery Test Software

IT9380 solar battery test software is the professional software aims for solar IV characteristic. With combination of ITECH programmable electronic loads IT8700/IT8800/IT8900, the solar battery test system is built up. It can test solar battery IV characteristic under kinds of Spectrums and light sources, and supports long time automatic testing. With the ambient temperature and sunlight irradiance changing, the IV characteristics and conversion efficiency of the solar battery will change. When the ambient temperature goes up, the shape of I-V curve will change at the same time and filling factor will godown. Also the conversion efficiency will decline. Sunlight irradiance increases, output power increases, then higher conversion efficiency for solar battery. All the above factors determine that the IV characteristics of solar batteries must be ensured the accurate test results by measuring voltage at multi-points in a period of time.

Feature

- Work with IT8700/IT8800/IT8900A/E series electronic loads for different DUTs
- Set up testing interval and time period, the software manages periodic scan during time period, automatic testing
- Support multi-channel testing at the same time, free to switch the interface of each channel
- Testing data can be exported to save in excel format

Functions & specification requirements

Equipment Name	Function Requirements	Specification Requirements	Recommended models
DC Electronic Load	1.High voltage and current measurement speed 2.High accuracy and high resolution	Single channel test	IT8800/IT8900A/E series
		Multi-channel test	IT8700 series

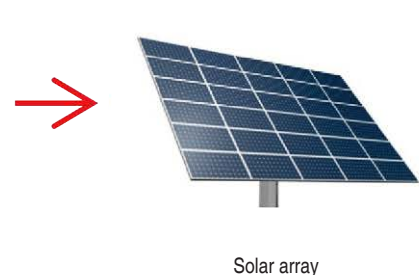
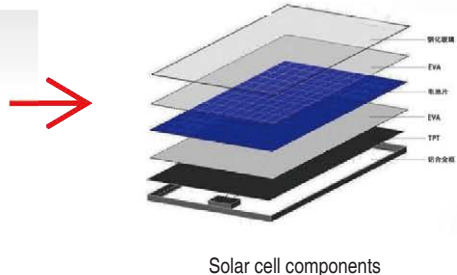
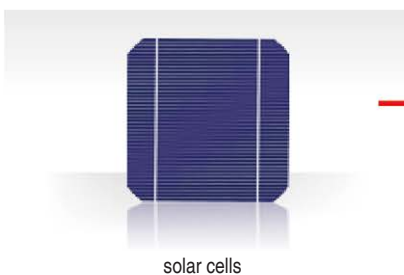

System structure

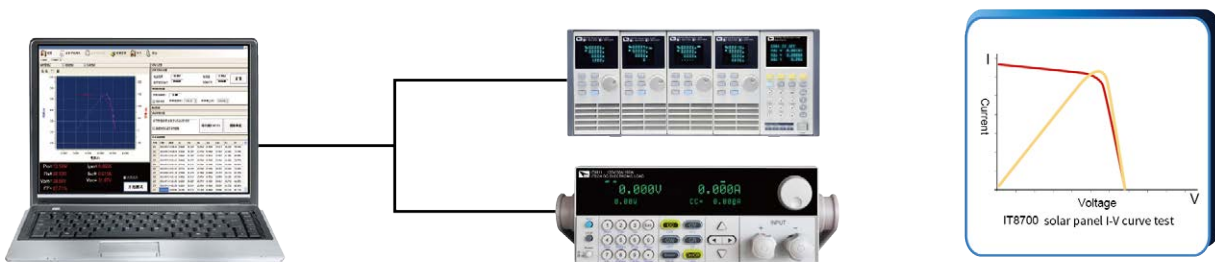



Test items

Test Parameters

Short circuit current(Ishort)

Open circuit voltage(Vopen)

Peak power(Pmax)

Peak power point voltage(Vpmax)

Peak power point current(Ipmax)

Fill factor(FF)

IT9380 Support connecting multiple units

IT9380 software supports multi-channel testing, It can monitor IT8700/IT8800/IT8900 in multiple channels running solar batteries testing by one computer and switch freely among the controlling interfaces.

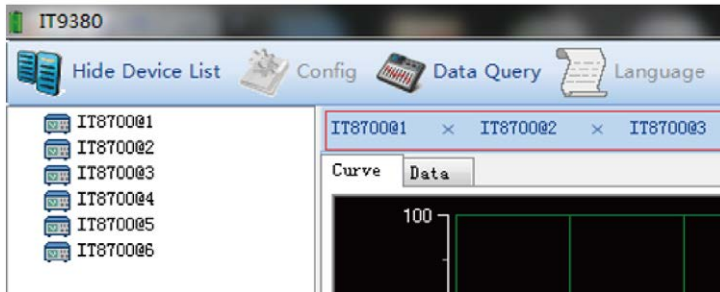

IT9380 Support Long Time Periodic Testing

Besides single test, IT9380 support multiple tests, the testing time interval and time range are available to set. The software automatically scans based on the time interval as the preset process.

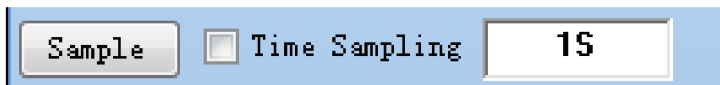

Powerful Data Management Ability

IT9380 software has batch data preservation function, you can delete or export/save your testing data in the data management interface.

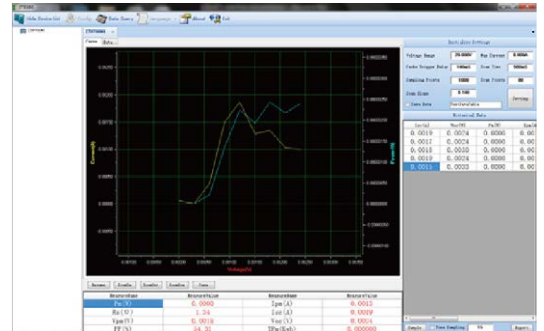

Table Name	Item	Value	Unit	Time
TestDataTab1	ISc	0.0002	A	0.0000
TestDataTab1	Voc	0.0041	V	0.0000
TestDataTab2	ISc	0.0001	A	0.0000
TestDataTab2	Voc	0.0041	V	0.0000
TestDataTab3	ISc	0.0009	A	0.0000
TestDataTab3	Voc	0.0008	V	0.0000
TestDataTab4	ISc	0.0025	A	0.0041
TestDataTab4	Voc	0.0041	V	0.0000

Automotive Junction Box Test System



Automotive junction box (automotive electrical central controller) integrates the whole car's fuse, circuit breaker, relay and so on. It is the vehicle electronic circuit control center. ITECH automotive junction box test system is established by high performance programmable electronic load, power supply and special-designed IT9360 software.

ITECH Test solution advantage

- Structure: Modular design, easy to move and disassemble. When one channel fails, will not affect the operation of the system
- Heat dissipation: Intelligent fan, good heat dissipation and low noise
- Function: High level automation
- Communication: Remote control via the computer, easy to show test results, reduce labor cost

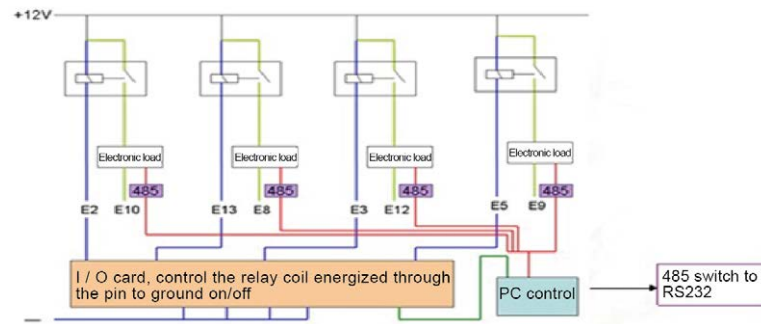

System test items

- Long time working stability
- Relay life test
- Fuse test
- Temperature monitor and fault alarm
- Other performance index

In addition to these test items, this test solution also provides powerful software features:

- Editable relay on-off timing
- Editable load current and run timing. Such as editing a cycle (load 5A on 5s off 10s), and then set the running time of such cycles
- When failure occurs for one channel, fault alarm will be shown on software interface.
- The failed channel stops running, and other channels continue running
- Each channel name can be edited, such as channel DUT is wiper, channel name is wiper
- Software operation interface displays voltage, current, temperature, run time, running status, load status, I/O status, and so on

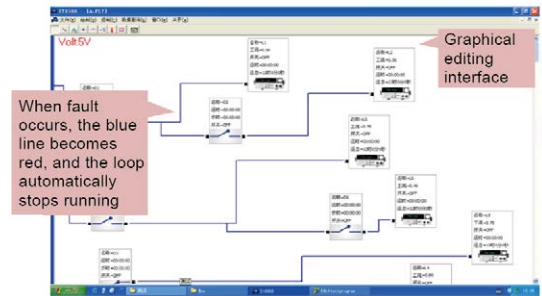

Test data include voltage, current, time and other information, can be exported in excel format to save.

Load data display

序号	通道	额定电流	额定电压	当前电流量	电压	运行时间	运行状态	故障原因
3976	A1	0.000000	0.000000	0.000	0.00V	0:00:00	OFF	0:01:29.910
3976	A3	11.700000	0.700000	0.300	13.76V	0:00:00	OFF	20:24:4.947.71
3976	A5	0.000000	0.000000	1.000	0.00V	0:00:00	OFF	20:24:4.948.21
3976	A8	11.700000	1.000000	1.140	13.76V	0:00:00	OFF	20:24:4.950.71
3976	A2	0.000000	0.000000	0.000	0.00V	0:00:00	OFF	20:24:4.952.21
3976	A4	11.700000	0.500000	0.300	13.76V	0:00:00	OFF	20:24:4.954.71
3976	A6	0.000000	0.000000	1.000	0.00V	0:00:00	OFF	20:24:4.957.21
3976	A7	11.700000	1.000000	1.140	0.00V	0:00:00	OFF	20:24:4.959.71

Relay data display

序号	通道名称	继电器名称	状态	运行时间	故障原因
3976	A1	Q1	OFF	00:00:19	OFF
3976	A3	Q2	OFF	00:00:20	OFF
3976	A5	Q3	OFF	00:00:21	OFF
3976	A7	Q4	OFF	00:00:22	OFF
3976	A9	Q5	OFF	00:00:23	OFF
3976	A11	Q6	OFF	00:00:24	OFF
3976	A13	Q7	OFF	00:00:25	OFF
3976	A15	Q8	OFF	00:00:26	OFF
3976	A17	Q9	OFF	00:00:27	OFF

Temperature monitor data display

序号	通道名称	温度名称	温度值	报警限
3976	A1	Q1	25.00	100.00





SAS1000 Solar Array Simulation Software



Applications

Solar array simulation, Photovoltaic inverter, Micro inverters and solar chargers

Feature

- Automatic wide range output, the voltage up to 2250V
- Power up to 2MW
- Support up to 20 solar cell power supplies for multi-channel MPPT testing*1
- Solar array simulate I-V function (Built-in I-V curve mathematical formula)
- Simulate the output characteristics of various solar cell (monocrystalline silicon cell, polysilicon cell, thin film cell) (Fill Factor)
- Simulate I-V curve under different temperature and irradiation
- Simulate I-V curve for solar panel under shadow
- Static & dynamic MPPT efficiency test
- Built-in EN50530, Sandia, NB/T32004, CGC/GF004, CGC/GF035 test program, and generate reports
- Graphical software interface, real-time test and display
- MPPT state of PV inverter
- Auto program control 100 I-V curves via Vm, Pm, FF, materials, regulations and other parameter points
- 100 * 128 points curves and 4096 points precise programming control.*2
- Support pre-program multiple IV curves (Vmp, Imp, Voc, Isc) and switch online*3
- List Mode

*1: Only applicable for SAS1000M

*2: IT-M3600 supports 10 curves and 1024 points control under Table Mode

*3: Not applicable for IT6500C

ITECH latest SAS1000 solar array simulation software, combined with high performance high power DC power supply, can accurately simulate solar array I-V curve. It has the characteristics of accurate measurement, high stability and fast response speed, etc. With the built-in EN50530 / Sandia / NB/T32004 / CGC/GF004 / CGC/GF035 SAS module, the solar array simulator enables easy programming on test regulations, materials, Vmp, Pmp parameters, so as to simulate I-V curve characteristic output and generate reports. These benefit much in test of the static & dynamic maximum power tracking performance of photovoltaic inverters.

ITECH SAS1000 solar array simulation software also provide Shadow and Table mode. The shadow mode is provided to allow users to edit any shielded I-V curves for dynamic shadow. Under Table mode, the user can select 4096 points matrix, or store 100 I-V curves of different temperature and irradiation in the memory, and can set the implementation sequence and time of each curve, to test the long-term MPPT performance evaluation under different climates. SAS1000M is also available for multi-channel MPPT testing. The solar panel output simulation under the 24-hour real environmental parameters is also available. As a solar simulator, our power supply also provides supports for micro-grid, distributed photovoltaic etc power system simulation and core equipments testing.

Applications

- Design & verify the MPPT circuit and algorithm of the PV inverter
- Verify static maximum power tracking efficiency of the PV inverter
- Verify the MPP voltage range and the full load MPP voltage range of the inverter
- Verify the MPPT performance of the inverter for dynamic curves (Built-in EN50530, Sandia, NB/T32004, CGC/GF004, CGC/GF035)
- Verify the inverter starting voltage and the maximum input voltage, the maximum input current and other electrical parameters
- Verify the MPPT mechanism of the inverter for the I-V curve when the solar cell is shaded by clouds or trees.
- Test inverter DC terminal OVP, OPP
- Verify micro-grid control center and control function of photovoltaic energy storage system
- Verify the MPPT performance of the inverter from early morning to nightfall
- Verify the total efficiency and conversion efficiency of the inverter with IT9100 power analyzer

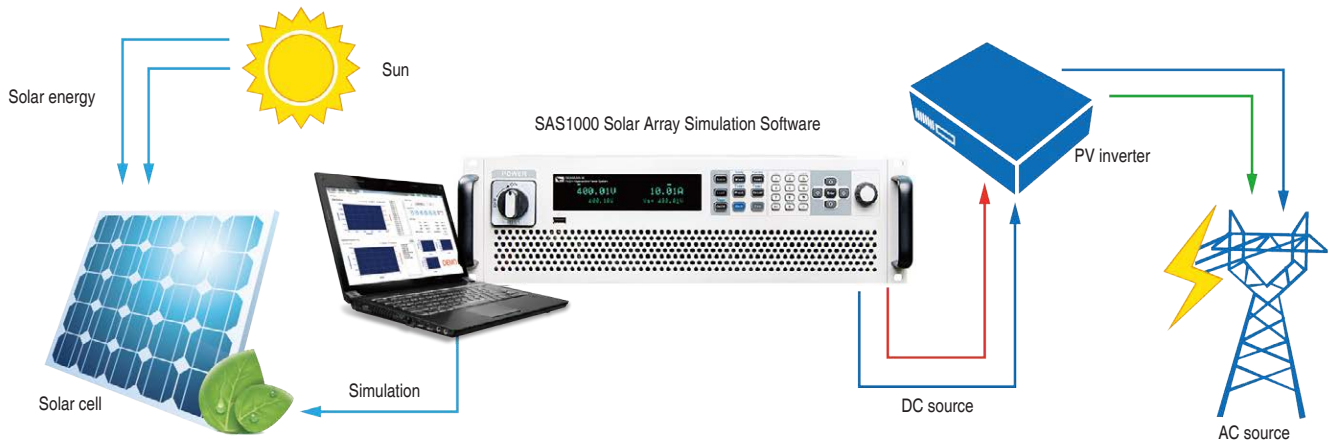

Model table

SAS1000	Suitable for IT6000C series, IT6000B series, IT6500C series, IT-M3600 series
SAS1000L	Suitable for IT6000C, IT6000B, IT6500C and IT-M3600 series with power ≤15KW
SAS1000M	Multi-channel version, support up to 20 solar cell power supplies for multi-channel MPPT testing

* For higher power test, please contact ITECH

Applicable model list

Series	Product Name	Specification
IT6000C	Bidirectional Programmable DC Power Supply	80~2250V / 5~1152kW
IT6000B	Regenerative Power System	80~2250V / 5~1152kW
IT6500C	Wide-range High-power DC Power Supply	80~1000V / 3~6kW
IT-M3600	Regenerative Power System	60~600V / 0.2~12.8kW

Simulate the output characteristics of various solar cell (FILL FACTOR)

Since solar cell utilization is not only related to its internal characteristics, but also related to weather, season, temperature, irradiation, cloud cover, rain and snow and other factors, solar cell has different I-V characteristics in different periods. Therefore, PV inverter must have a strategy to adjust real-time working point of the solar cell to make it always work in the vicinity of the maximum power point, this process is called MPPT. SAS1000 solar array simulation software can be used to directly simulate various real-life solar cell arrays in a laboratory test environment to test the static & dynamic MPPT performance of photovoltaic inverters.

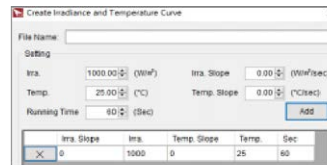
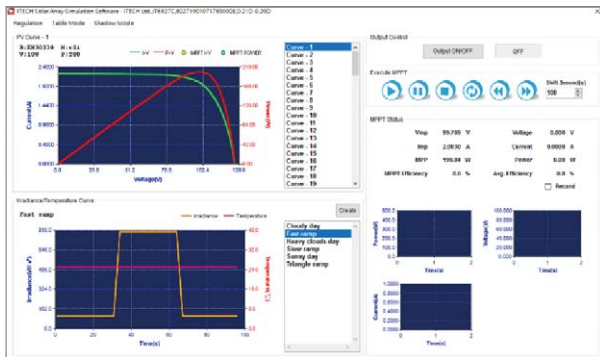

Set dwell time for each I-V curve to track MPPT and efficiency.

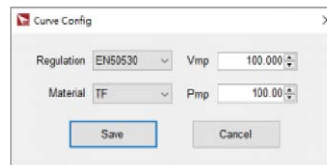

Easy to edit, save 1 - 100 I-V curves

SAS1000 solar array simulation software newly supports pre-program multiple IV curves (Vmp, Imp, Voc, Isc) and switch online function. During the software operation, users can also dynamically adjust the parameters of Voc, Vmp, Isc, Imp, illuminance and temperature curve. The curve will be adjusted in real time according to the new parameters, making the test more accurate.

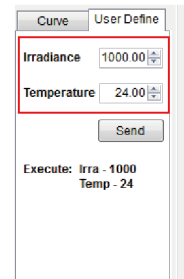
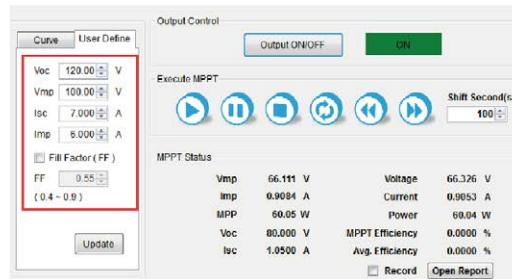
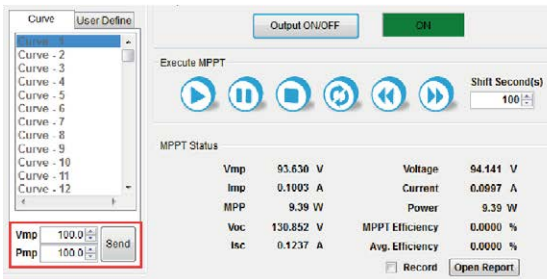

Test System

Graphical software interface

SAS1000 solar array simulation software has graphical software interface, users can easily use the software to output, measure, display the maximum power tracking status of photovoltaic inverter in real time and record value. Built-in EN50530, Sandia, NB/T32004, CGC/GF004, CGC/GF035 five kinds of regulatory testing procedures, it is convenient for users to test the static and dynamic MPPT performance of PV inverters and generate reports, so as to compare with competitors' results. Solar simulator power supply also provides the shadow, table and List mode, the user can enter the 128 ~ 4096 points array to edit any shielded I-V curve to achieve dynamic shadow effect and also can store 100 I-V curves under different irradiation and temperature to test the long-term maximum power tracking performance of photovoltaic inverters under different climatic conditions.

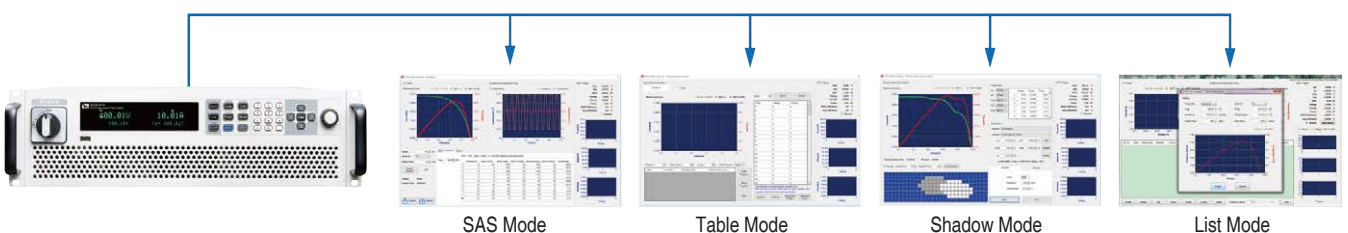

List Mode

SAS1000 solar array simulation software provides List mode, users can freely choose whether to simulate the curve by setting the Voc, Vmp, Isc, Imp or regulations, and then combine the different curves and run them in sequence.

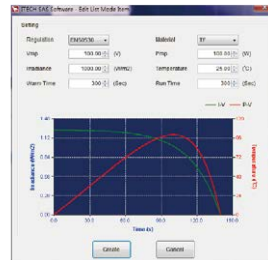
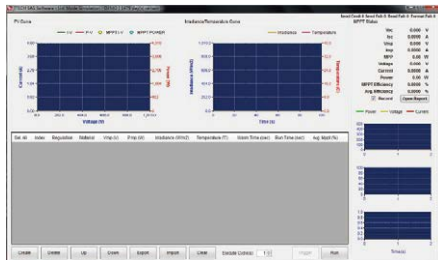

Curve Mode

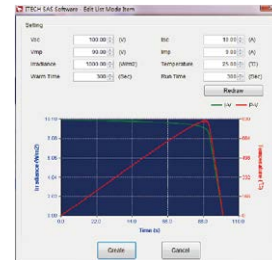

UserDefine Mode

Static & Dynamic MPPT performance test

MPPT tracking performance is a very important specification of PV inverter, PV inverter needs a built-in MPPT mechanism to track real-time maximum output power of solar cell. Therefore, some of the industry's organizations have defined some "standard" test patterns to match all kinds of inverters, which allows inverter manufacturers to test and improve MPPT performance. Build-in MPPT test program of EN50530, Sandia, NB/T32004, CGC/GF004, CGC/GF035, users can set their own Vmp, Pmp, materials and other parameters, test run time and maximum run power percentage, the I-V curve and the real-time trace process are displayed on the screen to verify MPPT performance of the PV inverter, record the data during the whole test and generate report.

Test the MPPT performance of PV inverter by easy programming illumination intensity with time

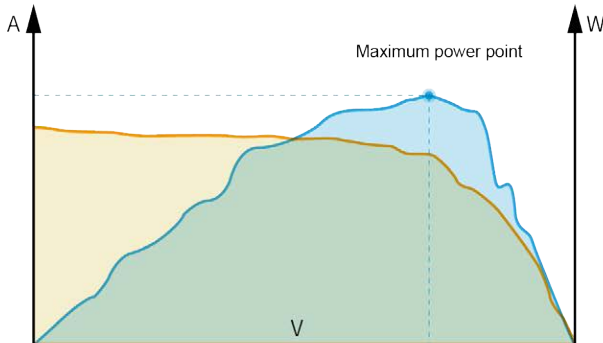

Test example Sandia

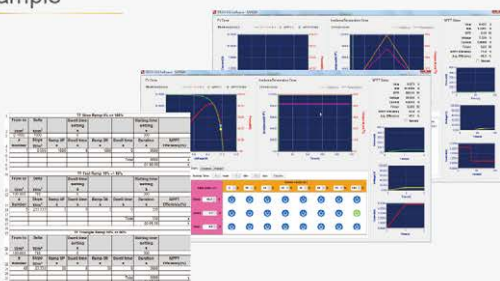

Test example EN50530

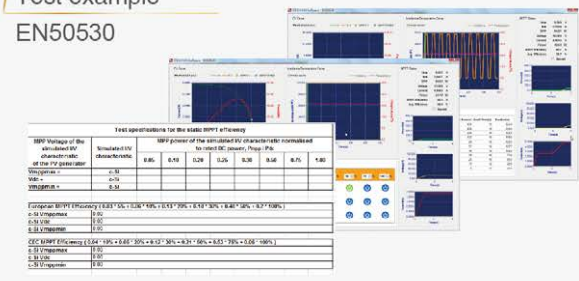

Automatic program(Table Mode)

Table Mode of SAS1000 solar array simulation software can facilitate users to quickly verify the MPPT performance of photovoltaic inverter in the R & D and quality testing. Users can define 100 curves which has 128 points on each curve, after selecting the Curve, Loop, Next program and other necessary information, the software can be test by the setting steps, report will be automatically generated after finished.

Table Program Test example

- 1 Run the first curve of the first program
- 2 Run the second curve of the first program after 5s
- 3 Clicking next, run the first curve of next program

Shield I-V curve simulation(Shadow Mode)

SAS1000 solar array simulation software can help users to complete the solar array output simulation under different shadow modes, test and track real-time maximum power and performance test of the PV array. Providing various Module for the user to choose according to different supplier, users can also build their own PV module. User can define irradiation and temperature parameters of shadow, cell string set, parallel quantity and dynamic shielding the moving direction of the cloud, initialization time, running time and the time interval of cloud moving.

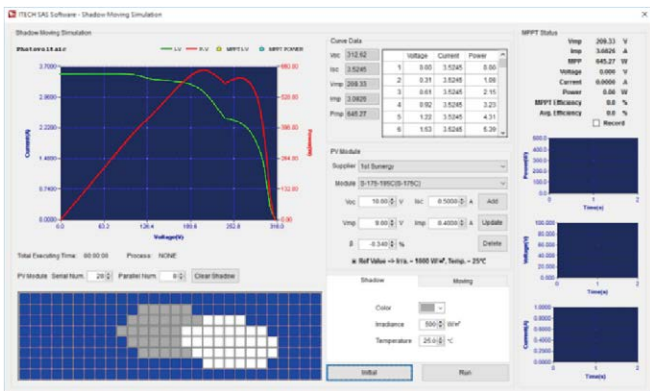

Shadow **Moving**

Initializing Time: 5 Sec
Executing Time: 3000 Sec
Changing Time: 5 Sec

Shadow **Moving**

Color: [Blue]
Irradiance: 1000 W/m²
Temperature: 25.0 °C

Select the moving direction of the cloud, initialization time, running time and the time interval of cloud moving

Set the irradiation and temperature parameters of clouds

Inverter conversion efficiency test

SAS1000 solar array simulation software is with built-in regulations EN50530, Sandia, NB/T32004, CGC/GF004, CGC/GF035 PV IV curve model, users can equip with IT9100 power meter to test conversion efficiency of photovoltaic inverter according to the maximum power percentage value.



IT9121 Power Meter

Report generation

SAS1000 solar array simulation software allows users to record the measured parameters, such as voltage, current, power, watts, MPPT efficiency, sampling time interval and total length of time, etc., which facilitates the analysis of PV inverter.

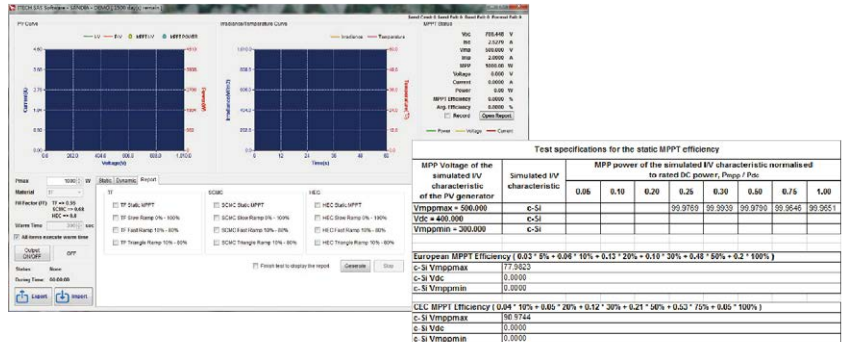

Multi-channel MPPT Test

SAS1000M multi-channel solar array simulation software supports up to 20 channels MPPT test, users can not only choose whether to perform single-channel test or multi-channel synchronous test. At the same time, users can also choose to copy the setting of one channel to several or all channels, which provides maximum flexibility for users to facilitate users to complete multi-channel testing.

View all channel MPPT execution information
Switch the current test interface

Set channel synchronization, open and close

The screenshot shows the main software interface with several key components:

- Channel Control:** A grid of 20 channels (CH1-CH20) with 'Sync' and 'Single' buttons for each.
- MPPT Monitor:** A detailed view of the MPPT status for each channel, including Vmp, Imp, Voc, Vsc, and Pwr.
- Graphs:** 'PV Curve' showing Current (A) vs Voltage (V) and 'Irradiance/Temperature Curve' showing Irradiance (W/m²) and Temperature (°C) vs Time (s).
- MPPT Status:** A central panel showing 'Execute MPPT' buttons (Start, Stop, Refresh) and real-time data: Vmp: 100.000 V, Imp: 1.0000 A, MPP: 100.04 W, Voc: 139.385 V, Isc: 1.2376 A, Voltage: 0.000 V, Current: 0.0000 A, Power: 0.00 W, MPPT Efficiency: 0.0000 %.

Channel test main interface, run MPPT test

View the output status and MPPT running information of all channels.

Test System

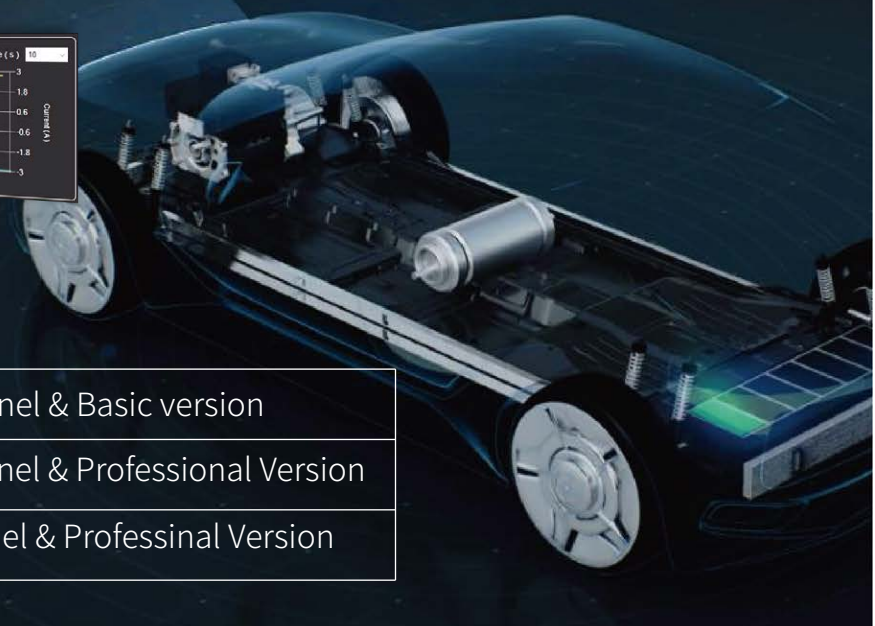
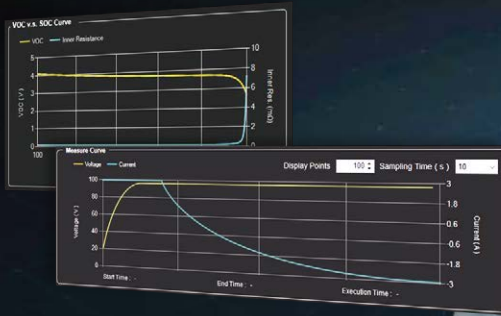

BSS2000	Single channel & Basic version
BSS2000 Pro	Single channel & Professional Version
BSS2000M	Multi-channel & Professional Version

With the development of battery technology, battery weight and energy density are further improved while the cost is reducing, making batteries widely used in new energy vehicles, photovoltaic energy storage and consumer electronics products. In order to fully verify the performance of the product in different SOC states of the battery, engineers need to conduct lots of tests in the early stage of R&D to continuously optimize the product design or select a more suitable battery.

The BSS2000/BSS2000 Pro/BSS2000M battery simulating software are products specifically designed for the above test scenarios. On the one hand, it will solve the problem of increasing cost of buying and storage of different types of batteries; On the other hand, the battery simulator can be quickly set to different state of SoC without real charge and discharge process, greatly improve test efficiency. The advanced version of BSS2000 Pro/BSS2000 M is developed to meet higher level testing requests. Based on the basic version of BSS2000, .mat file importing and more built-in battery types are provided with the Pro version software. Software combined with ITECH's latest high-performance bidirectional DC power supply, IT6000B/IT6000C/IT-M3400/IT-M3600/IT-M3900B/IT-M3900C, covering a power range up to 2MW, can provide users with a wide range simulation solution covering low-power battery module to high-power power battery system simulation.

Test System

Feature

- Battery simulation range: 2250V/2MW
- Support up to 20ch batteries simulation*1
- Bidirectional regenerative battery simulator, regenerative efficiency up to 95%
- Seamless switching between battery charging and discharging mode
- Support user-defined battery characteristic curve import
- Support quick set up of battery characteristic curves by input common parameters
- Support .mat file import function*2
- Built-in various battery types (include LAB,Li-on,LMO, LNMCO, LNMCO&LMO,LFP,LTO and NiMH .) *3
- Battery protection parameter setting function
- Initial SoC setting function
- Ideal data report function
- Battery curve preview and real-time curve display function
- Flexible expansion by parallel for larger current/power simulation request

*1 BSS2000M

*3 BSS2000 basic version software is used to simulate lead-acid and lithium-ion batteries.

*2 BSS2000Pro

Applications

E-mobility

EV Powertrain testing, DC Charger testing
FCEV PDU power distribution unit testing

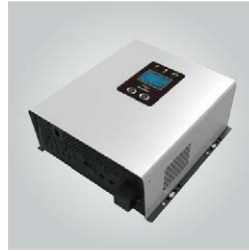

Solar PV

Renewable energy storage control unit test,
smart micro grid PCS testing



Others

Aerospace and defense energy storage battery
simulation test and more

Common battery parameters setting and function simulation

By combined various types of battery modelling and high-speed algorithms, BSS2000/BSS2000 Pro/BSS2000M Battery Simulation Software provide the user with real-time battery curve simulation function. No need to know the specific internal characteristics of the battery, the user only needs to select the battery type and the battery characteristic curve can be generated easily by setting a few basic parameters, parameters including full voltage, empty voltage, rated capacity, serial qty, parallel qty and battery internal resistance, etc. Thanks to the strong support of ITECH hardware, the battery simulator can simulate up to 1152kW battery packs, covering the test requests of solar PV ,energy storage, EV and other high-power fields.

Full Voltage (V)	12.00
Empty Voltage (V)	8.00
Inner Resistance (mΩ)	1.0
Capacity (Ah)	10.000
Parallel	1
Series	1
I+ (A)	5.00
I- (A)	-5.00
Initial SOC (%)	90.00

User-defined battery characteristic curve

BSS2000/BSS2000 Pro/BSS2000M Battery Simulation Software provides the battery curve simulation function by importing Data to meet the needs of various simulation requests. Users can import the measured battery charge and discharge data in a csv file to simulate the battery charge and discharge characteristic curve. This function is not only suitable for the simulation of conventional batteries, but also for the simulation of some special batteries or novel batteries.

SOC	OCV	R
0	2.654	7.25179
0.1	2.689676	6.28948
0.2	2.724133	5.463998
0.3	2.757411	4.755715
0.4	2.789552	4.147823
0.5	2.820595	3.625931
0.6	2.850577	3.177712
0.7	2.879535	2.792612
0.8	2.907504	2.461595

Support .mat file import function

BSS2000 Pro/BSS2000M

BSS2000 Pro/BSS2000M battery simulation software provides professional battery researchers with the function of importing .mat files, through which users can simulate the corresponding battery characteristic curves under different battery mathematical models. This function is of great significance for the research on the adaptability of new batteries and products, and the application of conventional batteries in special environments. Conventional types of battery characteristic curves or mathematical models are generally based on typical conditions, and for new batteries or applications in special environments, engineers often need to construct new battery mathematical models to more realistically reflect the performance of batteries in specific application contexts. This function is specially developed for such applications. Users can build a new battery mathematical model through a third-party MATLAB * simulation platform and import .mat file into BSS2000 Pro/BSS2000M for simulation, and then verify the battery's adaptability in practical applications.

* MATLAB is a mathematical software developed by MathWorks, USA

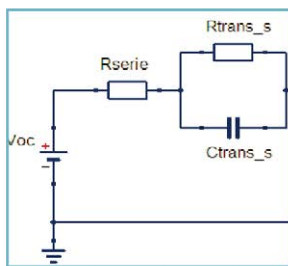

Battery mathematical model

Support .mat file import function

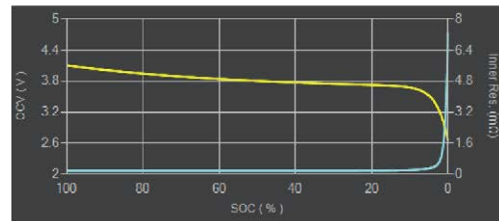

BSS2000 Pro Software

Built-in various batteries types for selection

BSS2000 Pro/BSS2000M

BSS2000 Pro/BSS2000M Battery Simulation Software provides users with unique Modelling functions, by built-in commonly used battery types and characteristic curves into the software. The user only needs to select the battery type and configure the series and parallel parameters to simulate the characteristic curves of battery modules of different types and different capacities. The battery types selectable by BSS2000 Pro include Lion, LMO, LNMCO, LNMCO&LMO, LFP, LTO and NiMH.

* BSS2000 basic version software is used to simulate lead-acid and lithium-ion batteries.

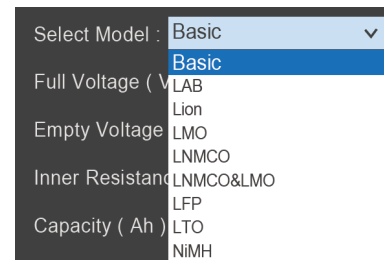

Test System

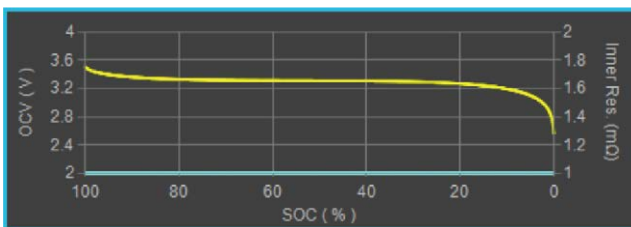

LFP

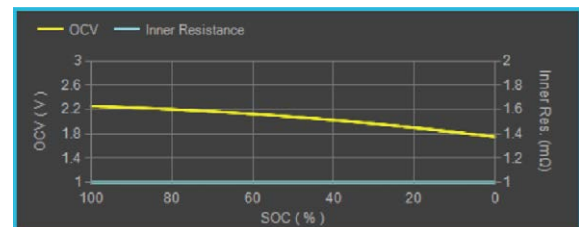

Lead-acid battery

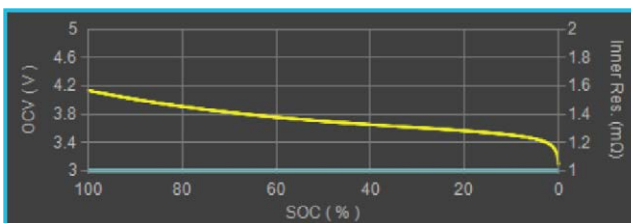

Ternary lithium battery

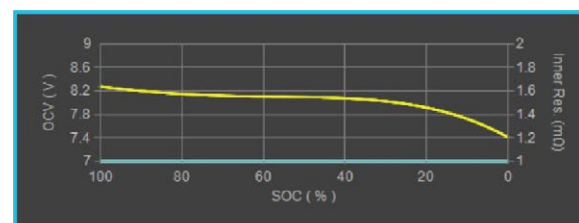

Ni/MH

Initial SoC setting function

The BSS2000/BSS2000 Pro/BSS2000M battery simulation software allows the user to set the initial capacity of the battery to study the startup characteristics or energy management characteristics of DUT when the battery is fully charged or depleted, without the need to perform real charging and discharging, and improve test efficiency.

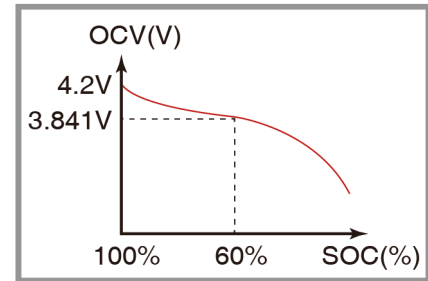

Real-time parameter monitoring

The BSS2000/BSS2000 Pro/BSS2000M battery simulation software provides multi-channel control function and supports preview function of edited curves. Meanwhile, during the test operation, the operating parameters and operating curves of the battery simulator are monitored in real time. In order to facilitate research and test personnel to trace the experimental data, the software provides report generation function, and the saved data includes voltage, current, power, SoC, charge/discharge status, and capacity.

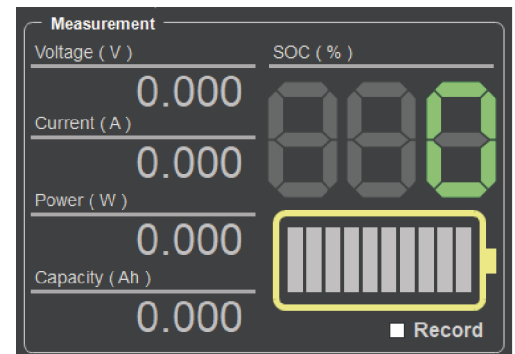

Seamless battery charge / discharge simulation

In real life scenarios, such as the EV field, as the vehicle decelerates, accelerates, or brakes, the battery continuously switches between the two states of discharge and energy recovery. Therefore, the battery simulator also needs to flexibly switch between being charged and discharge status and respond in a timely manner according to external state changes. The BSS2000/BSS2000 Pro/BSS 2000M battery simulator benefits from the hardware advantages of source and load in one device, which can realize the seamless switching between charging and discharging, to simulate the characteristics of the battery more realistically.

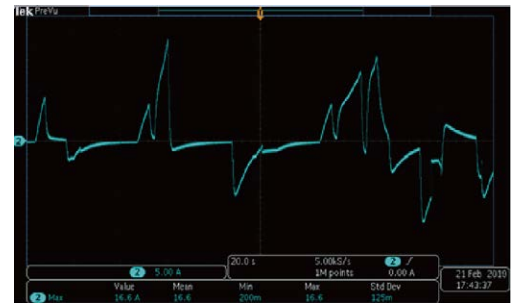

Protection parameter settings

In practical applications, in order to extend the service life of the battery and prevent the battery from overcharge and overdischarge, the BMS (battery management system) in the battery pack will limit the safety range of the battery for different applications. When it is higher or lower than the protection limit value, the software cut down the circuit in time to protect the battery and DUT. BSS2000/BSS2000 Pro/BSS2000M battery simulation software supports multiple protection condition settings: SoC upper/lower alarm value setting, SoC upper/lower protection value setting; OCV upper/lower alarm value setting, OCV upper/lower protection value setting.

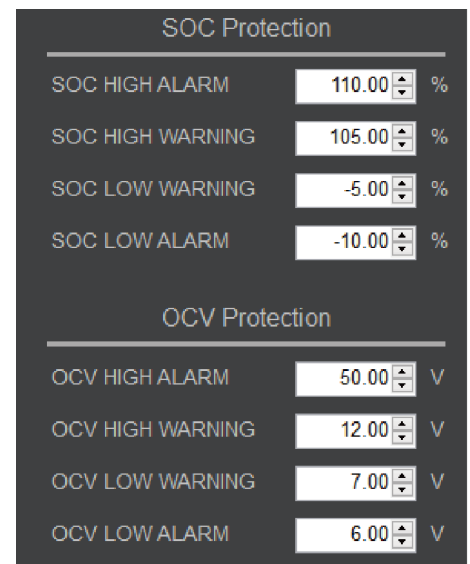

Battery Simulator

Application field 1 -Hydrogen fuel cell vehicle

Test purpose -verify the energy management strategies of fuel cells and lithium-ion battery packs

Mode 1 Power battery and fuel cell systems to power the motor

Mode 2 The fuel cell system powers the motor and charges the power battery at the same time (when the battery SOC is low)

Mode 3 Motor braking energy is feedback to power battery

ITECH solution -BSS2000 Pro & IT6000C/IT6000B

- Advantage**
- battery simulator can simulate power battery
 - battery simulator can realize seamless switching between charging and discharging
 - multiple built-in battery types (lithium battery, lithium iron phosphate battery...)

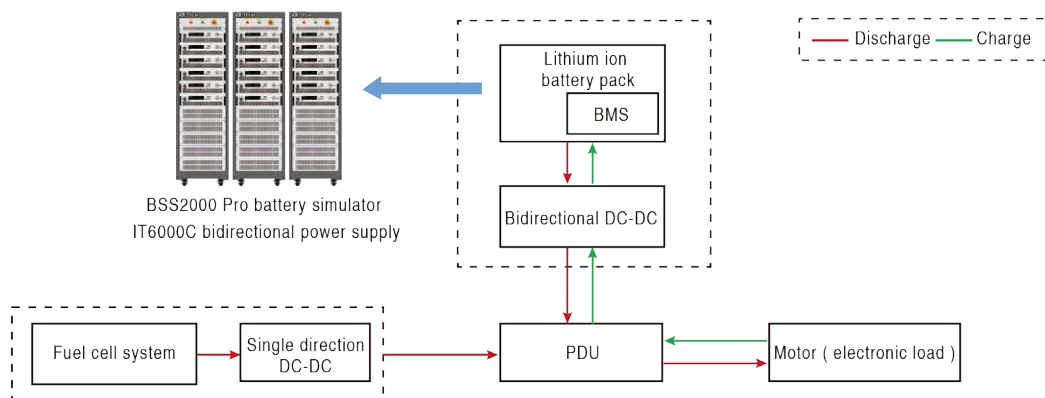
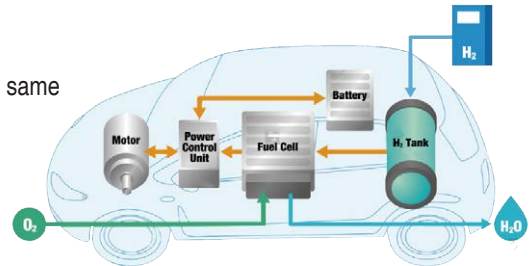

Application field 2 – MCU Test

Test purpose -verify the MCU performance under different SOC

ITECH solution -BSS2000 Pro & IT6000C/IT6000B

- Advantage**
- arbitrarily specify the initial SOC state of the battery
 - verifies the performance of the MCU under the limit state of the battery power
 - automatically absorb the reverse EMF of the motor to protect the MCU



BSS2000 battery simulator
IT6000C bidirectional power supply



Application field 3 – Smart grid

Test purpose -Verify the PCS electrical performance of energy storage converter

ITECH solution -BSS2000 Pro & IT6000C/IT6000 B

Advantage -max. power of battery simulator is up to 1152kW
-support multiple choices of battery types, including lithium battery, lead-acid battery, etc.

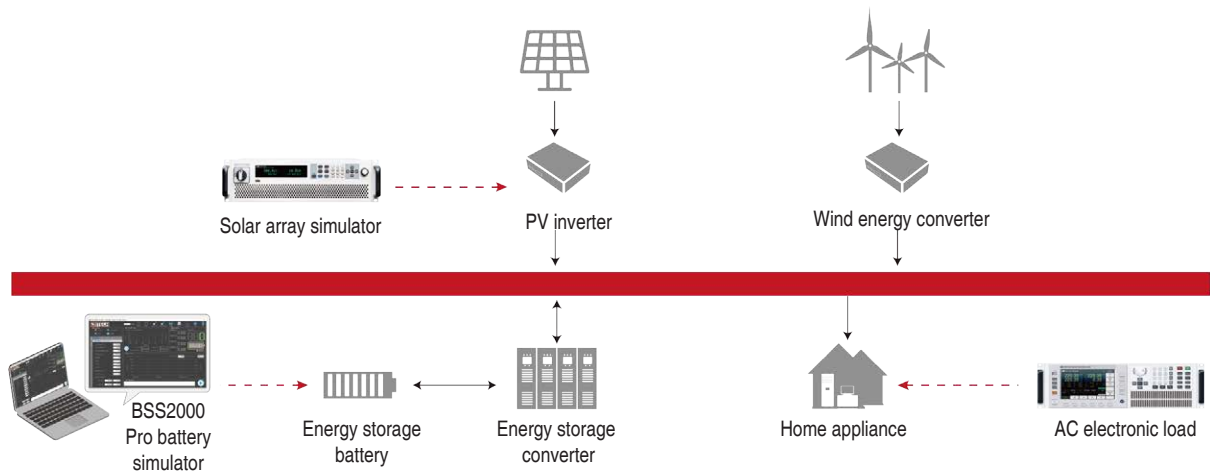

Application field 4- transportation

Test purpose -Research on Energy Distribution of Hydrogen Energy Tram Power System

ITECH solution -BSS2000 Pro & IT6000C/IT6000B

Advantage -user-defined battery characteristic curve
-supports the import of .mat format files, which is convenient for the performance research of the new kind of battery in the propulsion system
-real-time display of current battery voltage, current, capacity, energy and SOC

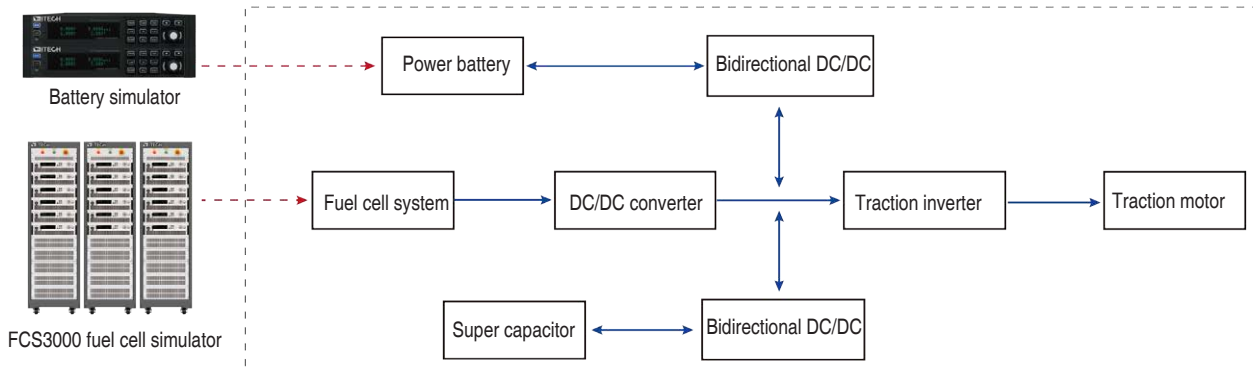



Application fields

- Electric ships and boats (Fuel cell/lithium-ion battery ships, FC AIP submarine...)
- Rail transportation (HFC Tram...)
- EV (HFC bus, HFC passenger car...)
- Distributed energy (Fuel cell peak shaving...)

The FCS3000 fuel cell simulation software matched with power supplies IT6000B/IT6000C/IT-M3900B/IT-M3900C, can accurately simulate the polarization characteristic curve of the fuel cell stack. The maximum voltage can reach 2250V and the power can be expanded to 1152kW to meet the test requirement of high-power fuel cell simulation.

FCS3000 is designed to replace real fuel cell systems and provide an efficient simulation platform for research on hydrogen energy hybrid propulsion systems. It can overcome the weakness of high cost, complex platform building and weakening of fuel cell performance in experiments testing with real fuel cell stacks. FCS3000 has simple interfaces which is easy for configuration. At the same time, the complete data report also provides important data support for theoretical research.

Feature

- Auto range output, 10V~2250V
- The power of the fuel cell simulator can be expanded to 2MW
- User-defined FC polarization curve (4096 points can be edited)
- Support .csv file import
- Data storage and export
- Graphical software operation interface, real-time display the output voltage, current and power

Application

- Study the power performance and economic performance of FC propulsion systems
- Verify the input performance of the FC DC-DC module
- Study the parameter matching of the key components of the FC propulsion system
- Research on vehicle energy management strategies for FC propulsion systems
- Verify the control strategy of peak and valley adjustment in distributed energy applications

Flexible parallel connection, power extended to max. 1152kW

The ITECH power supplies can be expanded to 1152kW through a simple master-slave parallel configuration. Different from the traditional parallel connection, IT6000B/IT6000C/IT-M3900B/IT-M3900C use optical fiber parallel technology.

After paralleling, the synchronization and performance of master and slave are almost the same as one single unit.

And there is no need to calibrate again, which greatly simplifies the parallel connection. Meanwhile it's helpful on cost control and high equipment utilization.

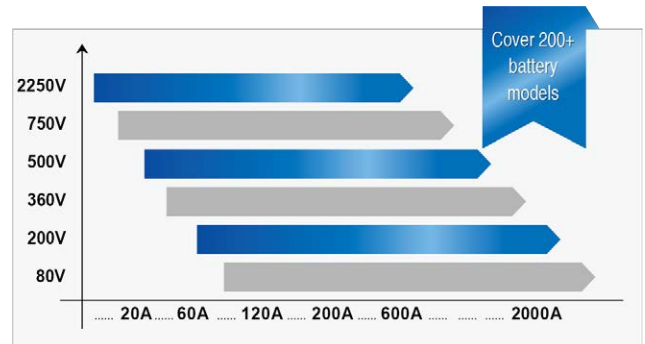

The fuel cell simulator is of great significance to the study of fuel cell propulsion systems.

What is fuel cell propulsion systems ?

A typical fuel cell propulsion system is mainly composed of a fuel cell stack, a hydrogen tank, a fuel cell boost DC-DC module, a lithium ion battery pack and an energy distribution control unit. When start-up of the ship or vehicle, the fuel cell is in a warm-up state, and the lithium ion battery pack provides energy to drive the motor; during driving, the fuel cell provides energy for the motor; when acceleration, both the fuel cell stack and the lithium ion battery pack provide energy for the motor; when braking, the recovered energy is stored in the power batteries.

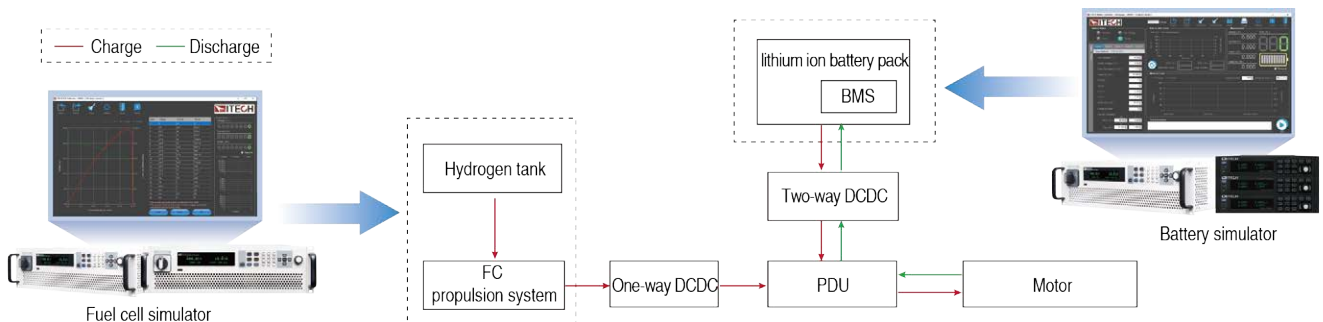

Compared with the traditional diesel engine as the motive power, the fuel cell power propulsion system has the advantages of no pollution, no emission and low noise. It is very suitable for applications requiring long driving mileage and high stability.

What is a fuel cell simulator ?

The fuel cell simulator replaces the real fuel cell stack and complex devices such as hydrogen and oxygen device, and provides an easy operating simulation platform for theoretical research. It also avoids the problems of high hydrogen cost and complex device building when using real fuel cells for testing. It's good for studying the energy distribution of the fuel cell propulsion system and evaluation of overall dynamic performance and economic value.

FCS3000 with IT6000B/IT6000C/IT-M3900B/IT-M3900C can provide a complete fuel cell simulation solution.

FCS3000-Graphical design interface to simulate fuel cell output polarization curve

The output voltage of a real fuel cell stack is affected by driving conditions. When the working current changes, the output voltage of the FC stack is a three-stage curve due to the internal polarization reaction, including electrochemical polarization zone and ohmic polarization zone and the concentration difference polarization zone.

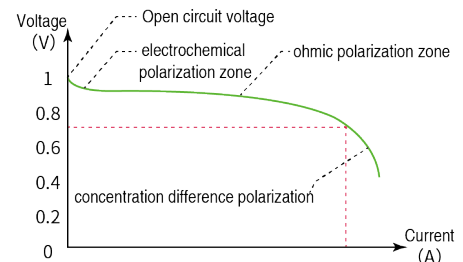

The FCS3000 software is based on the measured fuel cell polarization curve, and allows users to import the .csv file, download it to the device and realize the fuel cell output polarization characteristic curve simulation. In the experiment, the FCS3000 fuel cell simulation software changes the output voltage of the control system according to the polarization curve, and records the parameters such as voltage, current and power in real time, which helps to study fuel cell propulsion systems to provide important experimental data.

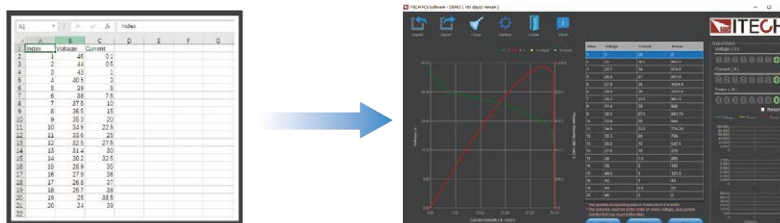



Communication interface

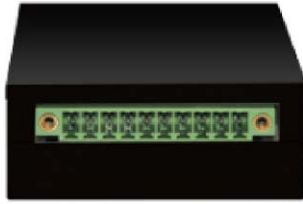

IT-E177

RS232 communication interface and analog interface
Applicable model:IT7800, IT7900



IT-E178

GPIB communication interface
Applicable model:IT7800, IT7900

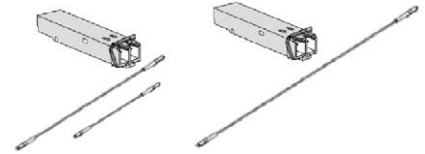

IT-E168 / IT-E169

Fiber optical kit for single unit or cabinet parallel connection
Applicable model: IT6000 series,IT7800, IT7900



IT-E121 RS232 Communication interface, with RS232 standard communication cable
Applicable model:IT6100, IT6800, IT6322, IT6302, IT8500+, IT8500



IT-E122 USB Communication interface, with USB standard communication cable
Applicable model:IT6100, IT6800, IT6322, IT6302, IT8500+, IT8500



IT-E123 RS485 Communication interface, with RS485 interface
Applicable model:IT8500+, IT8500, IT6800, IT6100, IT6322



IT-E1205 GPIB interface
Applicable model:IT-M series



IT-E1206 USB/LAN interface
Applicable model:IT-M series



IT-E1207 RS232/CAN interface
Applicable model:IT-M series



IT-E1208 External analog/RS485 interface
Applicable model:IT-M series



IT-E1209 USB interface
Applicable model:IT-M series



IT-E166 GPIB interface
Applicable model:IT8000, IT6000B, IT6000C,IT6000D



IT-E167 External analog/RS232 interface
Applicable model:IT8000, IT6000B, IT6000C,IT6000D

Optional keyboard



IT-253 Keyboard
Help IT8500 series electronic load to complete Auto-test function
Applicable model: IT8500 series



IT-254 Keyboard
Coordinating IT8500+ series electronic load to realize automatic testing function
Applicable model: IT8500+ series

Quick Charger Controller



IT-E255A
Applicable model: IT8500+ series

IT-E255M
Applicable model: IT8500+, IT8800, IT8700

Test leads

IT-E30110-AB	10A / 1m / Alligator clips - Banana plugs	A pair of red and black test line
IT-E30110-BB	10A / 1m / Banana plugs - Banana plugs	A pair of red and black test line
IT-E30110-BY	10A / 1m / Banana plugs - Y-type terminals	A pair of red and black test line
IT-E30312-YY	30A / 1.2m / Y-type terminals	A pair of red and black test line
IT-E30320-YY	30A / 2m / Y-type terminals	A pair of red and black test line
IT-E30615-OO	60A / 1.5m / Ring terminals	A pair of red and black test line
IT-E31220-OO	120A / 2m / Ring terminals	A pair of red and black test line
IT-E32410-OO	240A / 1m / Ring terminals	A pair of red and black test line
IT-E32420-OO	240A / 2m / Ring terminals	A pair of red and black test line
IT-E33620-OO	360A / 2m / Ring terminals	A pair of red and black test line

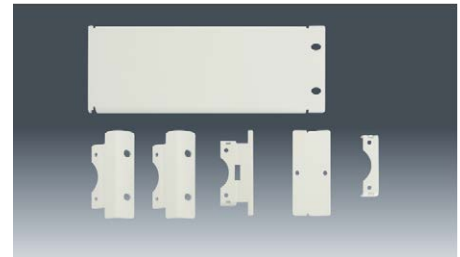

IT-E151A 19 Rack mount kit
Applicable model: IT8900 / IT8500 <1800W series, IT8811, IT8812, IT6800, IT6900, IT6322, IT6120, IT6150, IT6400, IT6700H (except IT6726)

Rack mount kit

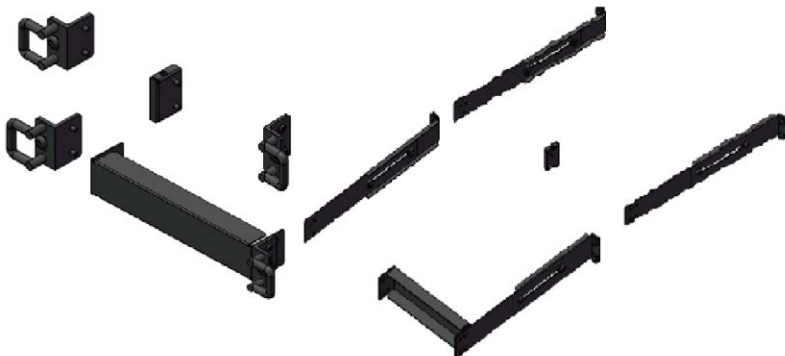

IT-E154A/IT-E154B Rack mount kit
Applicable model: IT-M series



IT-E152 Rack mount kit
Applicable model: IT8200/ IT6700 series



IT-E601 300V
IT-E601H 1000V
Pin type lead
Rubber straight plug – Probe crown round head
Applicable model:IT5100



IT-E602 300V
IT-E602H 1000V
Large clip type lead
Rubber straight plug – Alligator clips
Applicable model:IT5100



IT-E603 300V
IT-E603H 1000V
Pin type lead
Rubber straight plug – Probe double pin plugs
Applicable model:IT5100



IT-E604 300V
IT-E604H 1000V
Black straight plug - Universal pen + Alligator clip
Applicable model:IT5100

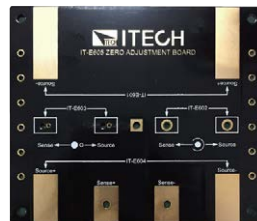

IT-E605
Zero adjustment board (suitable for different probe)
Applicable model:IT5100

Current sensor



IT - E185 (option)
Measuring fixture box (250 V / 15 A), easy wiring test
Applicable model:IT9100



IT-E190-25A (option)
Current sensor
Applicable model:IT9100, ITS9500



IT-E190-50A (option)
Current sensor
Applicable model:IT9100, ITS9500

IT-E165A / IT-E165B



IT-E165A is an optional anti-reverse protection module, suitable for IT6000B, IT6000C, IT6000D, IT8000 series products.

Model	Voltage	Current
IT-E165A-250	750V	250A
IT-E165A-400	750V	400A
IT-E165A-400	900V	400A



IT-E165B is an optional anti electromotive force module, suitable for IT6000B, IT6000C, IT6000D series instruments.

Model	Voltage	Current
IT-E165B	1200V	200A

AC electronic load

IT8200 Regenerative AC/DC Electronic Load P05		
Model	Specification	
IT8203-350-30U	350 V/30 A/3 kVA/1Φ	NEW
IT8205-350-30U	350 V/30 A/5 kVA/1Φ	NEW
IT8206-350-90	350 V/90 A/6kVA/1Φ or 3Φ	NEW
IT8209-350-90	350 V/90 A/9kVA/1Φ or 3Φ	NEW
IT8212-350-90	350 V/90 A/12kVA/1Φ or 3Φ	NEW
IT8215-350-90	350 V/90 A/15kVA/1Φ or 3Φ	NEW
IT8230-350-180	350 V/180 A/30kVA/1Φ or 3Φ	NEW
IT8245-350-270	350 V/270 A/45kVA/1Φ or 3Φ	NEW
IT8260-350-360	350 V/360 A/60kVA/1Φ or 3Φ	NEW
IT8275-350-450	350 V/450 A/75kVA/1Φ or 3Φ	NEW
IT8290-350-540	350 V/540 A/90kVA/1Φ or 3Φ	NEW
IT82105-350-630	350 V/630 A/105kVA/1Φ or 3Φ	NEW
IT82120-350-720	350 V/720 A/120kVA/1Φ or 3Φ	NEW
IT82135-350-810	350 V/810 A/135kVA/1Φ or 3Φ	NEW
IT82150-350-900	350 V/900 A/150kVA/1Φ or 3Φ	NEW
IT82165-350-990	350 V/990 A/165kVA/1Φ or 3Φ	NEW
IT8230M-350-180	350 V/180 A/30kVA/1Φ or 3Φ	NEW
IT8245M-350-270	350 V/270 A/45kVA/1Φ or 3Φ	NEW
IT8260M-350-360	350 V/360 A/60kVA/1Φ or 3Φ	NEW
IT8275M-350-450	350 V/450 A/75kVA/1Φ or 3Φ	NEW
IT8290M-350-540	350 V/540 A/90kVA/1Φ or 3Φ	NEW
IT82105M-350-630	350 V/630 A/105kVA/1Φ or 3Φ	NEW
IT82120M-350-720	350 V/720 A/120kVA/1Φ or 3Φ	NEW
IT82135M-350-810	350 V/810 A/135kVA/1Φ or 3Φ	NEW
IT82150M-350-900	350 V/900 A/150kVA/1Φ or 3Φ	NEW
IT82165M-350-990	350 V/990 A/165kVA/1Φ or 3Φ	NEW

IT8600 AC/DC Electronic Load P13		
Built-in communication interface: USB / LAN / front USB		
Model	Specification	
IT8615	50~420Vrms/20Arms/1800VA/1φ	
IT8615L	15~260Vrms/20Arms/1800VA/1φ	
IT8616	50~420Vrms/40Arms/3600VA/1φ	
IT8617	50~420Vrms/60Arms/5400VA/1φ or 3φ	
IT8624	50~420Vrms/80Arms/7200VA/1φ	
IT8625	50~420Vrms/100Arms/9000VA/1φ	
IT8626	50~420Vrms/120Arms/10.8kVA/1φ	
IT8627	50~420Vrms/140Arms/12.6kVA/1φ	
IT8628	50~420Vrms/160Arms/14.4kVA/1φ	

DC electronic load

IT-M3800 Regenerative DC Electronic Load P16		
Built-in : USB/CAN/LAN/Digital I/O Optional: GPIB&RS232Analog		
Model	Specification	
IT-M3801-10-120	10V / 120A / 1200W	
IT-M3802-10-240	10V / 240A / 2400W	
IT-M3803-10-360	10V / 360A / 3600W	
IT-M3807-10-720	10V / 720A / 7200W	
IT-M3802-32-80	32V / 80A / 2kW	
IT-M3804-32-160	32V / 160A / 4kW	
IT-M3806-32-240	32V / 240A / 6kW	
IT-M3812-32-480	32V / 480A / 12kW	
IT-M3802-80-40	80V / 40A / 2kW	
IT-M3804-80-80	80V / 80A / 4kW	
IT-M3806-80-120	80V / 120A / 6kW	
IT-M3812-80-240	80V / 240A / 12kW	
IT-M3802-300-20	300V / 20A / 2kW	
IT-M3804-300-40	300V / 40A / 4kW	
IT-M3806-300-60	300V / 60A / 6kW	
IT-M3812-300-120	300V / 120A / 12kW	
IT-M3802-500-12	500V / 12A / 2kW	
IT-M3804-500-24	500V / 24A / 4kW	
IT-M3806-500-36	500V / 36A / 6kW	
IT-M3812-500-72	500V / 72A / 12kW	
IT-M3802-800-8	800V / 8A / 2kW	

IT-M3800 Regenerative DC Electronic Load P16		
Built-in : USB/CAN/LAN/Digital I/O Optional: GPIB&RS232Analog		
Model	Specification	
IT-M3804-800-16	800V / 16A / 4kW	
IT-M3806-800-24	800V / 24A / 6kW	
IT-M3812-800-48	800V / 48A / 12kW	
IT-M3806-1500-12	1500V / 12A / 6kW	

IT-M3300 Regenerative DC Electronic Load P22		
Optional communication interface: RS232/USB/CAN/LAN/RS485/GPIB		
Model	Specification	
IT-M3312	60V/30A/200W	
IT-M3322	60V/30A/400W	
IT-M3332	60V/30A/800W	
IT-M3313	150V/12A/200W	
IT-M3323	150V/12A/400W	
IT-M3333	150V/12A/800W	
IT-M3314	300V/6A/200W	
IT-M3324	300V/6A/400W	
IT-M3334	300V/6A/800W	
IT-M3315	600V/3A/200W	
IT-M3325	600V/3A/400W	
IT-M3335	600V/3A/800W	

IT8000 Regenerative DC Electronic Load P28		
Built-in communication interface: USB/CAN/LAN/Digital I/O		
Model	Specification	
IT8005-80-150	80V/150A/5kW	
IT8010-80-300	80V/300A/10kW	
IT8015-80-450	80V/450A/15kW	
IT8030-80-900	80V/900A/30kW	
IT8045-80-1350	80V/1350A/45kW	
IT8060-80-1800	80V/1800A/60kW	
IT8075-80-2040	80V/2040A/75kW	
IT8090-80-2040	80V/2040A/90kW	
IT8105-80-2040	80V/2040A/105kW	

IT8000 Regenerative DC Electronic Load P28		
Built-in communication interface: USB/CAN/LAN/Digital I/O		
Model	Specification	
IT8120-80-2040	80V/2040A/120kW	
IT8006-300-75	300V/75A/6kW	
IT8012-300-150	300V/150A/12kW	
IT8018-300-225	300V/225A/18kW	
IT8036-300-450	300V/450A/36kW	
IT8054-300-675	300V/675A/54kW	
IT8072-300-900	300V/900A/72kW	
IT8090-300-1125	300V/1125A/90kW	
IT8108-300-1350	300V/1350A/108kW	
IT8126-300-1575	300V/1575A/126kW	
IT8144-300-1800	300V/1800A/144kW	
IT8006-500-40	500V/40A/6kW	
IT8012-500-80	500V/80A/12kW	
IT8018-500-120	500V/120A/18kW	
IT8036-500-240	500V/240A/36kW	
IT8054-500-360	500V/360A/54kW	
IT8072-500-480	500V/480A/72kW	
IT8090-500-600	500V/600A/90kW	
IT8108-500-720	500V/720A/108kW	
IT8126-500-840	500V/840A/126kW	
IT8144-500-960	500V/960A/144kW	
IT8006-800-25	800V/25A/ 6kW	
IT8012-800-50	800V/50A/12kW	
IT8018-800-75	800V/75A/18kW	
IT8036-800-150	800V/150A/36kW	
IT8054-800-225	800V/225A/54kW	
IT8072-800-300	800V/300A/72kW	
IT8090-800-375	800V/375A/90kW	
IT8108-800-450	800V/450A/108kW	
IT8126-800-525	800V/525A/126kW	
IT8144-800-600	800V/600A/144kW	

IT8000 Regenerative DC Electronic Load		P28
Built-in communication interface: USB/CAN/LAN/Digital I/O		
Model	Specification	
IT8018-1500-40	1500V/40A/18kW	
IT8036-1500-80	1500V/80A/36kW	
IT8054-1500-120	1500V/120A/54kW	
IT8072-1500-160	1500V/160A/72kW	
IT8090-1500-200	1500V/200A/90kW	
IT8108-1500-240	1500V/240A/108kW	
IT8126-1500-280	1500V/280A/126kW	
IT8144-1500-320	1500V/320A/144kW	
IT8018-2250-25	2250V/25A/18kW	
IT8036-2250-50	2250V/50A/36kW	
IT8054-2250-75	2250V/75A/54kW	
IT8072-2250-100	2250V/100A/72kW	
IT8090-2250-125	2250V/125A/90kW	
IT8108-2250-150	2250V/150A/108kW	
IT8126-2250-175	2250V/175A/126kW	
IT8144-2250-200	2250V/200A/144kW	

IT8700P+ High Speed Multi-channel DC Electronic Load		P32
Built-in communication interface:RS232/USB/GPIB/LAN		
Model	Specification	
IT8721P+	150 V/ 20 A/ 2 x 100 W	NEW
IT8731P+	150 V/ 40 A/ 200 W	NEW
IT8732P+	150 V/ 60 A/ 400 W	NEW
IT8722P+	150 V/ 20 A/ 2 x 250 W	NEW
IT8723P+	150 V/ 45 A/ 2 x 300 W	NEW
IT8733P+	150 V/ 120 A/ 600 W	NEW
IT8732BP+	600 V/ 20 A/ 300 W	NEW
IT8733BP+	600 V/ 30 A/ 500 W	NEW
IT8722BP+	600 V/ 15 A/ 2 x 250 W	NEW
IT8701P	Mainframe for 2 modules (including three interfaces)	NEW
IT8702P	Mainframe for 4 modules (including three interfaces)	NEW
IT8703P	Expansion mainframe for 4 modules	NEW

IT8700P Multi-channel Programmable DC Electronic Load		P36
Main frame has built-in communication interface: RS232 / USB / LAN		
Model	Specification	
IT8731P	80V/40A/200W	
IT8732P	80V/60A/400W	
IT8732BP	500V/20A/300W	
IT8733P	80V/120A/600W	
IT8733BP	500V/30A/500W	
IT8722P	80V/20A/250W*2	
IT8722BP	500V/15A/250W*2	
IT8723P	80V/45A/300W*2	
IT8701P	Two-load module main control unit	
IT8702P	Four-load module main control unit	
IT8703P	Four-load module expansion unit	

*1 IT8722P/IT8722BP two-way total power is 300W, the two-way simultaneous work need to meet:(50W ≤ PCH1/PCH2 ≤ 250W; PCH1+PCH2 ≤ 300W)

*2 IT8700P modules should be equipped with IT8702P mainframe.

IT8700 Multi-channel Programmable DC Electronic Load		P40
Main frame has built-in communication interface: RS232 / USB / LAN		
Model	Specification	
IT8731	80V/40A/200W	
IT8732	80V/60A/400W	
IT8732B	500V/20A/300W	
IT8733	80V/120A/600W	
IT8733B	500V/30A/500W	
IT8722	80V/20A/250W*2	
IT8722B	500V/15A/250W*2	
IT8723	80V/45A/300W*2	
IT8701	Two-load module main control unit	
IT8702	Four-load module main control unit	
IT8703	Four-load module expansion unit	

*1 IT8722/IT8722B two-way total power is 300W, the two-way simultaneous work need to meet:(50W ≤ PCH1/PCH2 ≤ 250W; PCH1+PCH2 ≤ 300W)

*2 IT8700 modules should be equipped with IT8702 mainframe

IT8400 High performance DC electronic load		P42
Built-in standard LAN, USB, RS232, GPIB, CAN and analog, IO interface		
Model	Specification	
IT8406-600-150	600 V/ 150 A/ 6 kW	
IT8406-1200-75	1200 V/ 75 A/ 6 kW	
IT8412-600-300	600 V/ 300 A/ 12 kW	
IT8412-1200-150	1200 V/ 150 A/ 12 kW	
IT8418-600-450	600 V/ 450 A/ 18 kW	
IT8418-1200-225	1200 V/ 225 A/ 18 kW	
IT8424-600-600	600 V/ 600 A/ 24 kW	
IT8424-1200-300	1200 V/ 300 A/ 24 kW	
IT8430-600-750	600 V/ 750 A/ 30 kW	
IT8430-1200-375	1200 V/ 375 A/ 30 kW	
IT8436-600-900	600 V/ 900 A/ 36 kW	
IT8436-1200-450	1200 V/ 450 A/ 36 kW	
IT8442-600-1050	600 V/ 1050 A/ 42 kW	
IT8442-1200-525	1200 V/ 525 A/ 42 kW	
IT8448-600-1200	600 V/ 1200 A/ 48 kW	
IT8448-1200-600	1200 V/ 600 A/ 48 kW	
IT8454-600-1350	600 V/ 1350 A/ 54 kW	
IT8454-1200-675	1200 V/ 675 A/ 54 kW	

IT8900A/E High Power DC Electronic Load		P48
Built-in communication interface: USB / GPIB / RS232 / LAN/CAN		
Model	Specification	
IT8902A-150-200	150V/200A/2kW	
IT8902E-150-200	150V/200A/2kW	
IT8902A-600-140	600V/140A/2kW	
IT8902E-600-140	600V/140A/2kW	
IT8902A-1200-80	1200V/80A/2kW	
IT8902E-1200-80	1200V/80A/2kW	
IT8904A-150-400	150V/400A/4kW	
IT8904E-150-400	150V/400A/4kW	
IT8904A-600-280	600V/280A/4kW	
IT8904E-600-280	600V/280A/4kW	
IT8904A-1200-160	1200V/160A/4kW	
IT8904E-1200-160	1200V/160A/4kW	
IT8906A-150-600	150V/600A/6kW	
IT8906E-150-600	150V/600A/6kW	
IT8906A-600-420	600V/420A/6kW	
IT8906E-600-420	600V/420A/6kW	
IT8906A/E-1200-240	1200V/240A/6kW	
IT8912A/E-150-1200	150V/1200A/12kW	
IT8912A/E-600-840	600V/840A/12kW	
IT8912A/E-1200-480	1200V/480A/12kW	
IT8918A/E-150-1800	150V/1800A/18kW	
IT8918A/E-600-1260	600V/1260A/18kW	
IT8918A/E-1200-720	1200V/720A/18kW	
IT8924A/E-150-2400	150V/2400A/24kW	
IT8924A/E-600-1680	600V/1680A/24kW	
IT8924A/E-1200-960	1200V/960A/24kW	
IT8930A/E-150-2400	150V/2400A/30kW	
IT8930A/E-600-2100	600V/2100A/30kW	
IT8930A/E-1200-2100	1200V/1200A/30kW	
IT8936A/E-150-2400	150V/2400A/36kW	
IT8936A/E-600-2400	600V/2400A/36kW	
IT8936A/E-1200-1440	1200V/1440A/36kW	
IT8942A/E-150-2400	150V/2400A/42kW	
IT8942A/E-600-2400	600V/2400A/42kW	
IT8942A/E-1200-1680	1200V/1680A/42kW	
IT8948A/E-150-2400	150V/2400A/48kW	
IT8948A/E-600-2400	600V/2400A/48kW	
IT8948A/E-1200-1920	1200V/1920A/48kW	
IT8954A/E-150-2400	150V/2400A/54kW	
IT8954A/E-600-2400	600V/2400A/54kW	
IT8954A/E-1200-2160	1200V/2160A/54kW	



IT8800 High Power DC Electronic Load P52
Built-in communication interface: USB / RS232

Model	Specification
IT8811	120V1 50W30A/150W
IT8812	120V/30A/250W
IT8812B	500V/15A/200W
IT8812C	120V/60A/250W
IT8813	120V/60A/750W
IT8813C	120V/120A/750W
IT8813B	500V/30A/750W
IT8814	120V/120A/1500W
IT8814B	500V/60A/1200W
IT8816	120V/240A/3000W
IT8816B	500V/100A/2500W
IT8817	120V/360A/4500W
IT8817B	500V/120A/3600W
IT8818	120V/480A/6000W
IT8818B	500V/150A/5000W
IT8814C	120V/240A/1.5kW
IT8816C	120V/480A/3kW
IT8817C	120V/600A/4.5W

IT8912E High Accuracy DC Electronic Load P57
Built-in communication interface: USB / RS232

Model	Specification
IT8912E	500V/15A/300W

IT8500G+ Programmable DC Electronic Load
Built-in communication interface: USB

Model	Specification
IT8511G+	150V / 30A / 150W (Standard USB)
IT8511AG+	150V / 30A / 150W (Standard USB)
IT8512G+	150V / 30A / 300W (Standard USB/LAN)
IT8512BG+	600V / 15A / 300W (Standard USB/LAN)

IT8500+ Programmable DC Electronic Load
Optional communication interface: RS485/RS232/USB

Model	Specification
IT8511+	120V/30A/150W
IT8511A+	150V/30A/150W
IT8511B+	500V/15A/150W
IT8512+	120V/30A/300W
IT8512A+	150V/30A/300W
IT8512B+	500V/1 5A/300W
IT8512C+	120V/60A/300W
IT8512H+	800V/5A/300W
IT8513A+	150V/60A/400W
IT8513C+	120V/120A/600W

Built-in communication interface: RS232/USB

Model	Specification
IT8514B+	500V/60A/1500W (Standard RS232/USB)
IT8514C+	120V/240A/1500W (Standard RS232/USB)
IT8516B+	120V/240A/3000W (Standard RS232/USB)

IT8200 Digital Control DC Electronic Load

Model	Specification
IT8211	60V/30A/150W

Programmable AC power supply

IT7900P High Performance Regenerative Grid Simulator P59

Model	Specification
IT7905P-350-30U	350V/30A/5kVA/1Φ NEW
IT7906P-350-90	350V/90A/6kVA/1Φor3Φ NEW
IT7909P-350-90	350V/90A/9kVA/1Φor3Φ NEW
IT7912P-350-90	350V/90A/12kVA/1Φor3Φ NEW
IT7915P-350-90	350V/90A/15kVA/1Φor3Φ NEW
IT7930P-350-180	350V/180A/30kVA/1Φor3Φ NEW
IT7945P-350-270	350V/270A/45kVA/1Φor3Φ NEW
IT7960P-350-360	350V/360A/60kVA/1Φor3Φ NEW
IT7975P-350-450	350V/450A/75kVA/1Φor3Φ NEW
IT7990P-350-540	350V/540A/90kVA/1Φor3Φ NEW

IT7900P High Performance Regenerative Grid Simulator P59

Model	Specification
IT79105P-350-630	350V/630A/105kVA/1Φor3Φ NEW
IT79120P-350-720	350V/720A/120kVA/1Φor3Φ NEW
IT79135P-350-810	350V/810A/135kVA/1Φor3Φ NEW
IT79150P-350-900	350V/900A/150kVA/1Φor3Φ NEW
IT79165P-350-990	350V/990A/165kVA/1Φor3Φ NEW
IT7930PM-350-180	350V/180A/30kVA/1Φor3Φ NEW
IT7945PM-350-270	350V/270A/45kVA/1Φor3Φ NEW
IT7960PM-350-360	350V/360A/60kVA/1Φor3Φ NEW
IT7975PM-350-450	350V/450A/75kVA/1Φor3Φ NEW
IT7990PM-350-540	350V/540A/90kVA/1Φor3Φ NEW
IT79105PM-350-630	350V/630A/105kVA/1Φor3Φ NEW
IT79120PM-350-720	350V/720A/120kVA/1Φor3Φ NEW
IT79135PM-350-810	350V/810A/135kVA/1Φor3Φ NEW
IT79150PM-350-900	350V/900A/150kVA/1Φor3Φ NEW
IT79165PM-350-990	350V/990A/165kVA/1Φor3Φ NEW

IT7900 Regenerative Grid Simulator P68
Built-in : USB/CAN/LAN/Digital I/O Optional: GPIB&RS232&Analog

Model	Specification
IT7905-350-30	350V/30A/5kVA 1Φ
IT7906-350-90	350V/90A/6kVA 1Φ or 3Φ
IT7909-350-90	350V/90A/9kVA 1Φ or 3Φ
IT7912-350-90	350V/90A/12kVA 1Φ or 3Φ
IT7915-350-90	350V/90A/15kVA 1Φor 3Φ
IT7930-350-180	350V/180A/30kVA1Φ or 3Φ
IT7945-350-270	350V/270A/45kVA 1Φor 3Φ
IT7960-350-360	350V/360A/60kVA 1Φ or 3Φ
IT7975-350-450	350V/450A/75kVA 1Φor 3Φ
IT7990-350-540	350V/540A/90kVA 1Φ or 3Φ
IT79105-350-630	350V/630A/105kVA 1Φ or 3Φ
IT79120-350-720	350V/720A/120kVA 1Φ or 3Φ
IT79135-350-810	350V/810A/135kVA 1Φor 3Φ
IT79150-350-900	350V/900A/150kVA 1Φ or 3Φ
IT79165-350-990	350V/990A/165kVA1Φ or 3Φ

IT7800 High Power Programmable AC/DC Power Supply P76
Built-in : USB/CAN/LAN/Digital I/O Optional: GPIB&RS232&Analog

Model	Specification
IT7803-350-30U	350V/30A/3kVA 1Φ
IT7803J-350-30U	350V/30A/3kVA 1Φ
IT7805-350-30U	350V/30A/5kVA 1Φ
IT7806-350-90	350V/90A/6kVA 1Φ or 3Φ
IT7809-350-90	350V/90A/9kVA 1Φ or 3Φ
IT7812-350-90	350V/90A/12kVA 1Φor 3Φ
IT7815-350-90	350V/90A/15kVA 1Φor 3Φ
IT7830-350-180	350V/180A/30kVA1Φ or 3Φ
IT7845-350-270	350V/270A/45kVA 1Φor 3Φ
IT7860-350-360	350V/360A/60kVA 1Φ or 3Φ
IT7875-350-450	350V/450A/75kVA 1Φor 3Φ
IT7890-350-540	350V/540A/90kVA 1Φ or 3Φ
IT78105-350-630	350V/630A/105kVA 1Φ or 3Φ
IT78120-350-720	350V/720A/120kVA 1Φ or 3Φ
IT78135-350-810	350V/810A/135kVA 1Φor 3Φ
IT78150-350-900	350V/900A/150kVA 1Φ or 3Φ
IT78165-350-990	350V/990A/165kVA1Φ or 3Φ

IT-M7700 High Performance Programmable AC Power Supply P82
Optional communication interface: RS232/USB/CAN/LAN/RS485/GPIB

Model	Specification
IT-M7721	300V / 3A / 300VA
IT-M7722	300V / 6A / 600VA
IT-M7722E	300V / 10A / 1000VA Coming soon
IT-M7723	300V / 12A / 1200VA
IT-M7723E	600V / 6A / 1200VA Coming soon
IT-M7724	300V / 15A / 1500VA Coming soon
IT-M7724	300V / 30A / 3000VA Coming soon
IT-M7724	600V / 15A / 3000VA Coming soon



IT7600 high performance programmable AC power supply
Built-in communication interface: USB/RS232/LAN/CAN 1 front USB **P87**

Model	Specification
IT7622	150V/300V,3A/750VA,1φ
IT7624	150V/300V/12A/1500VA,1φ
IT7625	150V/300V/36A/4500VA,1φ or 3φ
IT7626	150V/300V/24A/3000VA,1φ

IT7300 Programmable AC Power Supply
Built-in : USB/RS232/LAN **P92**

Model	Specification
IT7321	150V/300V,3A/1.5A,300VA,1φ
IT7322	150V/300V,6A/3A, 50VA,1φ
IT7324	150V/300V,12A/6A,500VA, φ
IT7326	150V/300V,24A/12A,3000VA,1φ
IT7322H	250V/500V,3A/1.5A, 50VA,1φ
IT7324H	250V/500V,6A/3A,1500VA,1φ
IT7326H	250V/500V,12A/6A,3000VA,1φ
IT7322T	150V/300V,6A/3A,2250VA,3φ
IT7324T	150V/300V,12A/6A,4500VA,3φ
IT7326T	150V/300V,24A/12A,9000VA,3φ
IT7322HT	250V/500V,3A/1.5A,2250VA,3φ
IT7324HT	250V/500V,6A/3A,4500VA,3φ
IT7326HT	250V/500V,12A/6A,9000VA,3φ

Programmable DC power supply

IT-N6900 Programmable DC Power Supply
Built-in : USB/LAN/Digital I/O **P94**

Model	Specification	
IT-N6952	60V/25A/850W	NEW
IT-N6962	60V/25A/1500W	NEW
IT-N6953	150V/10A/850W	NEW
IT-N6963	150V/10A/1500W	NEW

IT-M3140 Series Programmable DC Power Supply
Standard USB/LAN optional RS232 & analog, GPIB **P96**

Model	Specification	
IT-M3141	30V / 150A / 3000W	NEW
IT-M3142	80V / 80A / 3000W	NEW
IT-M3143	150V / 40A / 3000W	NEW
IT-M3144	300V / 20A / 3000W	NEW
IT-M3145	600V / 10A / 3000W	NEW
IT-M3146	1000V / 6A / 3000W	NEW
IT-M3147	1200V / 5A / 3000W	NEW
IT-M3131E	30V / 150A / 1850W	NEW
IT-M3132E	80V / 80A / 1850W	NEW
IT-M3133E	150V / 40A / 1850W	NEW
IT-M3134E	300V / 20A / 1850W	NEW
IT-M3135E	600V / 10A / 1850W	NEW
IT-M3136E	1000V / 6A / 1850W	NEW
IT-M3137E	1200V / 5A / 1850W	NEW
IT-E158A	For 2 units installed side by side in ITECH standard cabinet	NEW
IT-E158B	For 2 units installed side by side in non-ITECH cabinet	NEW
IT-E158C	For single unit installed in ITECH standard cabinet	NEW
IT-E158D	For single unit installed in non-ITECH cabinet	NEW
IT-E176	GPIB communication card	NEW
IT-E177	RS232 & Analog card	NEW

IT-M3900B Regenerative Power system
Built-in : USB/CAN/LAN/Digital I/O Optional:GPIB&RS232&Analog **P99**

Model	Specification
IT-M3901B-10-170	source: 10V / 170A / 1700W load: 10V / 120A / 1200W
IT-M3903B-10-340	source: 10V / 340A / 3400W load: 10V / 240A / 2400W
IT-M3905B-10-510	source: 10V / 510A / 5100W load: 10V / 360A / 3600W
IT-M3910B-10-1020	source: 10V / 1020A / 10200W load: 10V / 720A / 7200W
IT-M3902B-32-80	source: 32V / 80A / 2kW load: 32V / 80A / 2kW
IT-M3904B-32-160	source: 32V / 160A / 4kW load: 32V / 160A / 4kW
IT-M3906B-32-240	source: 32V / 240A / 6kW load: 32V / 240A / 6kW
IT-M3912B-32-480	source: 32V / 480A / 12kW load: 32V / 480A / 12kW
IT-M3902B-80-40	source: 80V / 40A / 2kW load: 80V / 40A / 2kW
IT-M3904B-80-80	source: 80V / 80A / 4kW load: 80V / 80A / 4kW
IT-M3906B-80-120	source: 80V / 120A / 6kW load: 80V / 120A / 6kW
IT-M3912B-80-240	source: 80V / 240A / 12kW load: 80V / 240A / 12kW

IT-M3900B Regenerative Power system
Built-in : USB/CAN/LAN/Digital I/O Optional:GPIB&RS232&Analog **P99**

Model	Specification
IT-M3902B-300-20	source: 300V / 20A / 2kW load: 300V / 20A / 2kW
IT-M3904B-300-40	source: 300V / 40A / 4kW load: 300V / 40A / 4kW
IT-M3906B-300-60	source: 300V / 60A / 6kW load: 300V / 60A / 6kW
IT-M3912B-300-120	source: 300V / 120A / 12kW load: 300V / 120A / 12kW
IT-M3902B-500-12	source: 500V / 12A / 2kW load: 500V / 12A / 2kW
IT-M3904B-500-24	source: 500V / 24A / 4kW load: 500V / 24A / 4kW
IT-M3906B-500-36	source: 500V / 36A / 6kW load: 500V / 36A / 6kW
IT-M3912B-500-72	source: 500V / 72A / 12kW load: 500V / 72A / 12kW
IT-M3902B-800-8	source: 800V / 8A / 2kW load: 800V / 8A / 2kW
IT-M3904B-800-16	source: 800V / 16A / 4kW load: 800V / 16A / 4kW
IT-M3906B-800-24	source: 800V / 24A / 6kW load: 800V / 24A / 6kW
IT-M3912B-800-48	source: 800V / 48A / 12kW load: 800V / 48A / 12kW
IT-M3906B-1500-12	source: 1500V / 12A / 6kW load: 1500V / 12A / 6kW

IT-M3900C Bidirectional Programmable DC Power Supply
Built-in : USB/CAN/LAN/Digital I/O Optional:GPIB&RS232&Analog **P104**

Model	Specification
IT-M3901C-10-170	10V / 170A / 1700W
IT-M3903C-10-340	10V / 340A / 3400W
IT-M3905C-10-510	10V / 510A / 5100W
IT-M3910C-10-1020	10V / 1020A / 10200W
IT-M3902C-32-80	32V / 80A / 2kW
IT-M3904C-32-160	32V / 160A / 4kW
IT-M3906C-32-240	32V / 240A / 6kW
IT-M3912C-32-480	32V / 480A / 12kW
IT-M3902C-80-40	80V / 40A / 2kW
IT-M3904C-80-80	80V / 80A / 4kW
IT-M3906C-80-120	80V / 120A / 6kW
IT-M3912C-80-240	80V / 240A / 12kW
IT-M3902C-300-20	300V / 20A / 2kW
IT-M3904C-300-40	300V / 40A / 4kW
IT-M3906C-300-60	300V / 60A / 6kW
IT-M3912C-300-120	300V / 120A / 12kW
IT-M3902C-500-12	500V / 12A / 2kW
IT-M3904C-500-24	500V / 24A / 4kW
IT-M3906C-500-36	500V / 36A / 6kW
IT-M3912C-500-72	500V / 72A / 12kW
IT-M3902C-500-12	800V / 8A / 2kW
IT-M3904C-500-24	800V / 16A / 4kW
IT-M3906C-500-36	800V / 24A / 6kW
IT-M3912C-500-72	800V / 48A / 12kW
IT-M3906C-1500-12	1500V / 12A / 6kW

IT-M3900D High power DC power supply
Built-in : USB/CAN/LAN/Digital I/O Optional:GPIB&RS232&Analog **P109**

Model	Specification
IT-M3901D-10-170	10V / 170A / 1700W
IT-M3903D-10-340	10V / 340A / 3400W
IT-M3905D-10-510	10V / 510A / 5100W
IT-M3910D-10-1020	10V / 1020A / 10200W
IT-M3902D-32-80	32V / 80A / 2kW
IT-M3904D-32-160	32V / 160A / 4kW
IT-M3906D-32-240	32V / 240A / 6kW
IT-M3912D-32-480	32V / 480A / 12kW
IT-M3902D-80-40	80V / 40A / 2kW
IT-M3904D-80-80	80V / 80A / 4kW
IT-M3906D-80-120	80V / 120A / 6kW
IT-M3912D-80-240	80V / 240A / 12kW
IT-M3902D-300-20	300V / 20A / 2kW
IT-M3904D-300-40	300V / 40A / 4kW
IT-M3906D-300-60	300V / 60A / 6kW
IT-M3912D-300-120	300V / 120A / 12kW
IT-M3902D-500-12	500V / 12A / 2kW
IT-M3904D-500-24	500V / 24A / 4kW
IT-M3906D-500-36	500V / 36A / 6kW
IT-M3912D-500-72	500V / 72A / 12kW
IT-M3902D-800-12	800V / 8A / 2kW
IT-M3904D-800-24	800V / 16A / 4kW
IT-M3906D-800-36	800V / 24A / 6kW
IT-M3912D-800-72	800V / 48A / 12kW
IT-M3906D-1500-12	1500V / 12A / 6kW

IT-M3100 Ultra-compact Wide Range DC Power Supply P115
 Optional communication interface: RS232/USB/CAN/LAN/RS485/GPIB

Model	Specification
IT-M3110	20V/100A/400W
IT-M3120	20V/100A/850W
IT-M3111	30V/70A/400W
IT-M3121	30V/70A/850W
IT-M3112	80V/22A/400W
IT-M3122	80V/22A/850W
IT-M3113	150V/12A/400W
IT-M3123	150V/12A/850W
IT-M3114	300V/6A/400W
IT-M3124	300V/6A/850W
IT-M3115	600V/3A/400W
IT-M3125	600V/3A/850W

IT-M3100D Dual-channel DC Power Supply P119

Model	Specification
IT-M3131D	CH1:30V/15A/200W; CH2:30V/15A/200W
IT-M3141D	CH1:30V/15A/400W; CH2:30V/15A/400W
IT-M3132D	CH1:60V/10A/200W; CH2:60V/10A/200W
IT-M3142D	CH1:60V/10A/400W; CH2:60V/10A/400W

IT-M3200 High-precision Programmable dC power P123
 Optional communication interface: RS232/USB/CAN/LAN/RS485/GPIB

Model	Specification
IT-M3223	60V/10A/100W
IT-M3233	60V/10A/200W
IT-M3243	60V/10A/360W
IT-M3253	20V/20A/100W
IT-M3263	20V/20A/200W
IT-M3273	20V/20A/360W

IT-M3400 Bidirectional DC Power Supply P128
 Optional communication interface: RS232/USB/CAN/LAN/RS485/GPIB

Model	Specification
IT-M3412	60V/30A/200W
IT-M3422	60V/30A/400W
IT-M3432	60V/30A/800W
IT-M3413	150V/12A/200W
IT-M3423	150V/12A/400W
IT-M3433	150V/12A/800W
IT-M3414	300V/6A/200W
IT-M3424	300V/6A/400W
IT-M3434	300V/6A/800W
IT-M3415	600V/3A/200W
IT-M3425	600V/3A/400W
IT-M3435	600V/3A/800W

IT-M3600 Regenerative Power System P134
 Optional communication interface: RS232/USB/CAN/LAN/RS485/GPIB

Model	Specification
IT-M3612	60V/30A/200W
IT-M3622	60V/30A/400W
IT-M3632	60V/30A/800W
IT-M3613	150V/12A/200W
IT-M3623	150V/12A/400W
IT-M3633	150V/12A/800W
IT-M3614	300V/6A/200W
IT-M3624	300V/6A/400W
IT-M3634	300V/6A/800W
IT-M3615	600V/3A/200W
IT-M3625	600V/3A/400W
IT-M3635	600V/3A/800W

IT6000B Regenerative Power System P140
 Built-in communication interface: USB/CAN/LAN/Digital I/O

Model	Specification
IT6005B-80-150	80V/150A/5kW
IT6010B-80-300	80V/300A/10kW
IT6015B-80-450	80V/450A/15kW
IT6030B-80-900	80V/900A/30kW
IT6045B-80-1350	80V/1350A/45kW
IT6060B-80-1800	80V/1800A/60kW
IT6075B-80-2040	80V/2040A/75kW
IT6090B-80-2040	80V/2040A/90kW
IT6105B-80-2040	80V/2040A/105kW
IT6120B-80-2040	80V/2040A/120kW
IT6006B-300-75	300V/75A/6kW
IT6012B-300-150	300V/150A/12kW
IT6018B-300-225	300V/225A/18kW
IT6036B-300-450	300V/450A/36kW
IT6054B-300-675	300V/675A/54kW
IT6072B-300-900	300V/900A/72kW
IT6090B-300-1125	300V/1125A/90kW
IT6108B-300-1350	300V/1350A/108kW
IT6126B-300-1575	300V/1575A/126kW
IT6144B-300-1800	300V/1800A/144kW
IT6006B-500-40	500V/40A/6kW
IT6012B-500-80	500V/80A/12kW
IT6018B-500-120	500V/120A/18kW
IT6036B-500-240	500V/240A/36kW
IT6054B-500-360	500V/360A/54kW
IT6072B-500-480	500V/480A/72kW
IT6090B-500-600	500V/600A/90kW
IT6108B-500-720	500V/720A/108kW
IT6126B-500-840	500V/840A/126kW
IT6144B-500-960	500V/960A/144kW
IT6006B-800-25	800V/25A/6kW
IT6012B-800-50	800V/50A/12kW
IT6018B-800-75	800V/75A/18kW
IT6036B-800-150	800V/150A/36kW
IT6054B-800-225	800V/225A/54kW
IT6072B-800-300	800V/300A/72kW
IT6090B-800-375	800V/375A/90kW
IT6108B-800-450	800V/450A/108kW
IT6126B-800-525	800V/525A/126kW
IT6144B-800-600	800V/600A/144kW
IT6018B-1500-40	1500V/40A/18kW
IT6036B-1500-80	1500V/80A/36kW
IT6054B-1500-120	1500V/120A/54kW
IT6072B-1500-160	1500V/160A/72kW
IT6090B-1500-200	1500V/200A/90kW
IT6108B-1500-240	1500V/240A/108kW
IT6126B-1500-280	1500V/280A/126kW
IT6144B-1500-320	1500V/320A/144kW
IT6018B-2250-25	2250V/25A/18kW
IT6036B-2250-50	2250V/50A/36kW
IT6054B-2250-75	2250V/75A/54kW
IT6072B-2250-100	2250V/100A/72kW
IT6090B-2250-125	2250V/125A/90kW
IT6108B-2250-150	2250V/150A/108kW
IT6126B-2250-175	2250V/175A/126kW
IT6144B-2250-200	2250V/200A/144kW

IT6000C Bidirectional Programmable DC Power Supply Built-in communication interface: USB/CAN/LAN/Digital I/O		P147
Model	Specification	
IT6005C-80-150	80V/150A/5kW	
IT6010C-80-300	80V/300A/10kW	
IT6015C-80-450	80V/450A/15kW	
IT6030C-80-900	80V/900A/30kW	
IT6045C-80-1350	80V/1350A/45kW	
IT6060C-80-1800	80V/1800A/60kW	
IT6075C-80-2040	80V/2040A/75kW	
IT6090C-80-2040	80V/2040A/90kW	
IT6105C-80-2040	80V/2040A/105kW	
IT6120C-80-2040	80V/2040A/120kW	
IT6006C-300-75	300V/75A/6kW	
IT6012C-300-150	300V/150A/12kW	
IT6018C-300-225	300V/225A/18kW	
IT6036C-300-450	300V/450A/36kW	
IT6054C-300-675	300V/675A/54kW	
IT6072C-300-900	300V/900A/72kW	
IT6090C-300-1125	300V/1125A/90kW	
IT6108C-300-1350	300V/1350A/108kW	
IT6126C-300-1575	300V/1575A/126kW	
IT6144C-300-1800	300V/1800A/144kW	
IT6006C-500-40	500V/40A/6kW	
IT6012C-500-80	500V/80A/12kW	
IT6018C-500-120	500V/120A/18kW	
IT6036C-500-240	500V/240A/36kW	
IT6054C-500-360	500V/360A/54kW	
IT6072C-500-480	500V/480A/72kW	
IT6090C-500-600	500V/600A/90kW	
IT6108C-500-720	500V/720A/108kW	
IT6126C-500-840	500V/840A/126kW	
IT6144C-500-960	500V/960A/144kW	
IT6006C-800-25	800V/25A/ 6kW	
IT6012C-800-50	800V/50A/12kW	
IT6018C-800-75	800V/75A/18kW	
IT6036C-800-150	800V/150A/36kW	
IT6054C-800-225	800V/225A/54kW	
IT6072C-800-300	800V/300A/72kW	
IT6090C-800-375	800V/375A/90kW	
IT6108C-800-450	800V/450A/108kW	
IT6126C-800-525	800V/525A/126kW	
IT6144C-800-600	800V/600A/144kW	
IT6018C-1500-40	1500V/40A/18kW	
IT6036C-1500-80	1500V/80A/36kW	
IT6054C-1500-120	1500V/120A/54kW	
IT6072C-1500-160	1500V/160A/72kW	
IT6090C-1500-200	1500V/200A/90kW	
IT6108C-1500-240	1500V/240A/108kW	
IT6126C-1500-280	1500V/280A/126kW	
IT6144C-1500-320	1500V/320A/144kW	
IT6018C-2250-25	2250V/25A/18kW	
IT6036C-2250-50	2250V/50A/36kW	
IT6054C-2250-75	2250V/75A/54kW	
IT6072C-2250-100	2250V/100A/72kW	
IT6090C-2250-125	2250V/125A/90kW	
IT6108C-2250-150	2250V/150A/108kW	
IT6126C-2250-175	2250V/175A/126kW	
IT6144C-2250-200	2250V/200A/144kW	

IT6000D High Power Programmable DC Power Supply Built-in communication interface: USB/CAN/LAN/Digital I/O		P151
Model	Specification	
IT6005D-80-150	80V/150A/5kW	
IT6010D-80-300	80V/300A/10kW	
IT6015D-80-450	80V/450A/15kW	
IT6030D-80-900	80V/900A/30kW	
IT6045D-80-1350	80V/1350A/45kW	
IT6060D-80-1800	80V/1800A/60kW	
IT6075D-80-2040	80V/2040A/75kW	
IT6090D-80-2040	80V/2040A/90kW	
IT6105D-80-2040	80V/2040A/105kW	
IT6120D-80-2040	80V/2040A/120kW	
IT6006D-300-75	300V/75A/6kW	
IT6012D-300-150	300V/150A/12kW	
IT6018D-300-225	300V/225A/18kW	
IT6036D-300-450	300V/450A/36kW	
IT6054D-300-675	300V/675A/54kW	
IT6072D-300-900	300V/900A/72kW	
IT6090D-300-1125	300V/1125A/90kW	
IT6108D-300-1350	300V/1350A/108kW	
IT6126D-300-1575	300V/1575A/126kW	
IT6144D-300-1800	300V/1800A/144kW	
IT6006D-500-40	500V/40A/6kW	
IT6012D-500-80	500V/80A/12kW	
IT6018D-500-120	500V/120A/18kW	
IT6036D-500-240	500V/240A/36kW	
IT6054D-500-360	500V/360A/54kW	
IT6072D-500-480	500V/480A/72kW	
IT6090D-500-600	500V/600A/90kW	
IT6108D-500-720	500V/720A/108kW	
IT6126D-500-840	500V/840A/126kW	
IT6144D-500-960	500V/960A/144kW	
IT6006D-800-25	1500V/40A/18kW	
IT6012D-800-50	1500V/80A/36kW	
IT6018D-800-75	1500V/120A/54kW	
IT6036D-800-150	1500V/160A/72kW	
IT6054D-800-225	1500V/200A/90kW	
IT6072D-800-300	1500V/240A/108kW	
IT6090D-800-375	1500V/280A/126kW	
IT6108D-800-450	1500V/320A/144kW	
IT6126D-800-525	2250V/25A/18kW	
IT6144D-800-600	2250V/50A/36kW	
IT6018D-1500-40	2250V/75A/54kW	
IT6036D-1500-80	2250V/100A/72kW	
IT6054D-1500-120	2250V/125A/90kW	
IT6072D-1500-160	2250V/150A/108kW	
IT6090D-1500-200	2250V/175A/126kW	
IT6108D-1500-240	2250V/200A/144kW	
IT6126D-1500-280	800V/25A/ 6kW	
IT6144D-1500-320	800V/50A/12kW	
IT6018D-2250-25	800V/75A/18kW	
IT6036D-2250-50	800V/150A/36kW	
IT6054D-2250-75	800V/225A/54kW	
IT6072D-2250-100	800V/300A/72kW	
IT6090D-2250-125	800V/375A/90kW	
IT6108D-2250-150	800V/450A/108kW	
IT6126D-2250-175	800V/525A/126kW	
IT6144D-2250-200	800V/600A/144kW	

IT6400 Bipolar DC Power Supply / Battery Simulator Built-in communication interface: USB / LAN / front USB		P153
Model	Specification	
IT6402	CH1: -6V-0V,0-6V CH1: ±2A CH1: 12W CH2: 0-6V CH2: ±2A CH2: 12W	
IT6411	±15V/±9V/±3A/±5A/45W	
IT6411S	-15V-0V,0-15V/±0.1A/1.5W	
IT6412	CH1: ±15V/±9V CH1: ±3A/±5A CH1: 45W CH2: 0-15V/0-9V CH2: ±3A/±5A CH1: 45W	
IT6412S	CH1: -15V-0V,0-15V CH1: ±0.1A/1.5W CH1: 1.5W CH2: 0-15V CH2: ±0.1A/1.5W CH2: 1.5W	
IT6431	-15V-0V,0-15V/±10A/150W	
IT6432	-30V-0V,0-30V/±5A/150W	
IT6432S	-30V-0V,0-30V/±21mA/0.63W	
IT6433	-60V-0V,0-60V/±2.5 A/150W	

IT6500 Wide-range High-power DC Power Supply Built-in communication interface: USB / RS232 / RS485		P155
Model	Specification	
IT6502D	80V/60A/800W	
IT6512	80V/60A/1200W (Support List, DIN waveforms)	
IT6512A	80V/60A/1200W	
IT6513	150V/30A/1200W (Support List, DIN waveforms)	
IT6513A	150V/30A/1200W	

IT6500 Wide-range High-power DC Power Supply Built-in communication interface: USB / RS232 / CAN / LAN		P155
Model	Specification	
IT6512C	80V/120A/1800W	
IT6512D	80V/120A/1800W	
IT6513C	200V/60A/1800W	
IT6513D	200V/60A/1800W	
IT6514C	360V/30A/1800W	
IT6514D	360V/30A/1800W	
IT6515C	500V/20A/1800W	
IT6515D	500V/20A/1800W	
IT6516C	750V/15A/1800W	
IT6516D	750V/15A/1800W	
IT6517C	1000V/10A/1800W	
IT6517D	1000V/10A/1800W	
IT6522C	80V/120A/3kW	
IT6522D	80V/120A/3kW	
IT6523C	200V/60A/3kW	
IT6523D	200V/60A/3kW	
IT6524C	360V/30A/3kW	
IT6524D	360V/30A/3kW	
IT6525C	500V/20A/3kW	
IT6525D	500V/20A/3kW	
IT6526C	750V/15A/3kW	
IT6526D	750V/15A/3kW	
IT6527C	1000V/10A/3kW	
IT6527D	1000V/10A/3kW	
IT6532C	80V/240A/6kW	
IT6532D	80V/240A/6kW	
IT6533C	200V/120A/6kW	
IT6533D	200V/120A/6kW	
IT6534C	360V/60A/6kW	
IT6534D	360V/60A/6kW	
IT6535C	500V/40A/6kW	
IT6535D	500V/40A/6kW	
IT6536C	750V/30A/6kW	
IT6536D	750V/30A/6kW	
IT6537C	1000V/20A/6kW	
IT6537D	1000V/20A/6kW	

*1 IT6500C is high speed multi-function DC power supply, IT6500D is stable multi-function DC power supply

IT6900B Wide -range Programmable DC Power Supply Built-in communication interface: USB / RS232		P159
Model	Specification	
IT6922A	60V/5A/100W	
IT6932A	60V/10A/200W	
IT6933A	150V/5A/200W	
IT6942A	60V/15A/360W	
IT6952A	60V/25A/600W	
IT6953A	150V/10A/600W	

Built-in communication interface: USB / RS232 / RS485 / external analog	
Model	Specification
IT6922B	60V/5A/100W
IT6932B	60V/10A/200W
IT6942B	60V/15A/360W
IT6952B	60V/25A/600W
IT6953B	150V/10A/600W

IT6800A/B Single Channel Programmable DC Power Supply Built-in communication interface: RS232 / USB		P161
Model	Specification	
IT6831A	18V/10A/180W	
IT6832A	32V/6A/192W	
IT6833A	72V/3A/216W	
IT6835A	50V/4A/200W	

IT6800A/B Single Channel Programmable DC Power Supply Built-in communication interface: RS232 / USB / GPIB	
Model	Specification
IT6832B	32V/6A/192W
IT6833B	72V/3A/216W
IT6835B	50V/4A/200W

IT6800A / B Dual range programmable DC power supply Built-in communication interface: RS232 / USB	
Model	Specification
IT6861A	20V/5A/100W 8V/9A/72W
IT6862A	32V/3A/96W 12V/6A/72W
IT6863A	72V/1.5A/108W 32V/3A/96W
IT6872A	35V/4A/140W 15V/7A/105W
IT6873A	0-75V,2A/0-32V,4A
IT6874A	0-150V,1.2A/0-60V,2A

Built-in communication interface: RS232 / USB / GPIB	
Model	Specification
IT6861B	20V/5A/100W 8V/9A/72W
IT6862B	32V/3A/96W 12V/6A/72W
IT6863B	72V/1.5A/108W 32V/3A/96W
IT6872B	35V/4A/140W 15V/7A/105W
IT6873B	75V/2A/150W 32V/4A/128W
IT6874B	150V/1.2A/180W 60V/2A/120W

IT6800 High Performance DC Power Supply Optional communication interface: GPIB / RS232 / USB	
Model	Specification
IT6821	18V/5A/90W
IT6822	32V/3A/96W
IT6823	72V/1.5A/108W
IT6831	18V/10A/180W
IT6832	32V/6A/192W
IT6833	72V/3A/216W
IT6834	150V/1.2A/180W



IT6700H High Voltage DC Power Supply P163
Built-in communication interface: USB / RS232

Model	Specification
IT6722	80V/20A/400W, with GPIB
IT6722A	80V/20A/400W
IT6723B	150V/20A/850W
IT6723C	32V/110A/850W
IT6723	80V/40A/850W
IT6723G	600V/5A/850W
IT6723H	300V/10A/850W
IT6724C	32V/110A/1500W
IT6724	80V/40A/1500W
IT6724B	150V/20A/1500W
IT6724H	300V/10A/1500W
IT6724G	600V/5A/1500W
IT6726B	160V/40A/3KW
IT6726C	32V/220A/3KW
IT6726H	300V/20A/3KW
IT6726G	600V/10A/3KW
IT6726V	1200V/5A/3KW

IT6700 DC Power Supply

Model	Specification
IT6720	60V/5A/100W
IT6721	60V/8A/180W

IT6100B High Accuracy DC Power Supply P165
Built-in communication interface: USB / RS232

Model	Specification
IT6121B	20V/5A/100W
IT6122B	32V/3A/96W
IT6123B	72V/1.2A/86W
IT6132B	30V/5A/150W
IT6133B	60V/2.5A/150W
IT6162B	20V/50A/1000W
IT6164B	30V/40A/1200W 60V/20A/1200W

IT6100 DC Power Supply P166
Optional communication interface: USB / RS232 / GPIB

Model	Specification
IT6151	5.2V/60A/312W
IT6152	20V/27A/540W
IT6153	30V/18A/540W
IT6154	60V/9A/540W

IT6300 Triple Channels DC power supply P167

Model	Specification
IT6302	30V/3A/90W*2CH Optional communication interface: USB/RS232 5V/3A/15W*1CH Optional communication interface: USB/RS232
IT6322	30V/3A/90W*2CH Optional communication interface: USB/GPIB/RS232 5V/3A/15W*1CH Optional communication interface: USB/GPIB/RS232

Built-in communication interface: USB / RS232

Model	Specification
IT6322A	30V/3A/90W*2CH 5V/3A/15W*1CH
IT6332A	30V/6A/180W*2CH 5V/3A/15W*1CH
IT6333A	60V/3A/180W*2CH 5V/3A/15W*1CH

Built-in communication interface: USB / RS232 / GPIB

Model	Specification
IT6322B	30V/3A/90W*2CH 5V/3A/15W*1CH
IT6332B	30V/6A/180W*2CH 5V/3A/15W*1CH
IT6333B	60V/3A/180W*2CH 5V/3A/15W*1CH

Built-in communication interface: USB / LAN

Model	Specification
IT6322C	30V/3A/90W*2CH 5V/3A/15W*1CH
IT6332C	30V/6A/180W*2CH 5V/3A/15W*1CH
IT6333C	60V/3A/180W*2CH 5V/3A/15W*1CH
IT6341C	6V/16A/80W*1CH 16V/5A/80W*1CH

Source Measure Unit P168

IT2800 Graphical Source Measure Unit
Built-in communication interface: Digital IO/USB/LAN

Model	Specification
IT2801	1000V/1A/20W*1CH NEW
IT2805	200V/1.5A/20W*1CH NEW
IT2806	200V/3A DC/ 10A Pulse/20W*1CH NEW

Power meter P177

IT9100 Power Meter
Built-in communication interface: USB /RS232 / Ethernet
communication interface
Front USB interface

Model	Specification
IT9121	600V/20A AC power meter (with harmonic measurement)
IT9121C	600V/50A
IT9121E	600V/20A
IT9121H	1000V/20A
IT-E185	Power meter test fixture

Battery tester P179

IT5100 Battery tester
Built-in communication interface: USB / LAN // front USB interface

Model	Specification
IT5101	-300V~-+300V/3mΩ~3000Ω
IT5101E	-300V~-+300V/300mΩ~3Ω
IT5101H	-1000V~-+1000V/3mΩ~3000Ω



Automotive Electronics Test Solutions



IT6000C Bidirectional Programmable DC Power Supply



IT8900A/E High Performance High Power DC Electronic Load



IT6400 Series Bipolar DC Power Supply / Battery Simulator



IT6500 Series Wide-range High-power DC Power Supply



IT-M3400 Bidirectional DC Power Supply



EV Test Solutions



IT7900P Regenerative Grid Simulator



IT6000C Bidirectional Programmable DC Power Supply



IT8000 Series Regenerative DC Electronic Load



Battery Test/ Simulation Solutions



ITS5300 Battery Charge&Discharge Test System



IT6400 Series Bipolar DC Power Supply / Battery Simulator



IT6000C Bidirectional Programmable DC Power Supply



IT5100 Battery Tester



IT-M3900C Bidirectional DC Power Supply

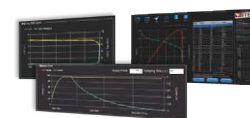

BSS2000 Battery Simulation Software
FCS3000 Fuel Cell Simulation Software

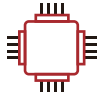

**Semiconductor /
IC Test Solutions**



IT6400 Series Bipolar
DC Power Supply / Battery Simulator



IT6100B High Speed
High Precision Programmable
DC Power Supply



IT-M3200 High Precision
Programmable DC Power Supply



IT2800 Series
Power Meter / uA Level Power Test



IT6500 Series Wide-range
High-power DC Power Supply



IT6000C Bidirectional
Programmable DC Power Supply



**Power Supply
Test Solutions**



IT7800 High Power
Programmable AC/DC Power Supply



IT6000D Series High Power
Programmable DC Power Supply



IT-M7700 High Performance
Programmable AC Power Supply



IT8700P Multi-channel
Programmable DC Electronic Load



IT8200 Series
AC / DC Electronic Load



**Industrial
Equipment
Test Solutions**



IT6000B Series
Regenerative Power System



IT-M3300 Series
Regenerative DC Electronic Load



IT8000 Series
Regenerative DC Electronic Load



IT7900P High Performance
Regenerative Grid Simulator



IT8900A/E High Performance
High Power DC Electronic Load



IT-M3140 Series
High Voltage DC Power Supply

Solar / Inverter Solutions



SAS1000
Solar Array Simulation Software



IT6000C Bidirectional
Programmable DC Power Supply



IT-M3600
Regenerative Power System



BSS
Solar Battery Test Software



IT7900P Regenerative
Grid Simulator



IT8700P Multi-channel
Programmable DC Electronic Load

IoT Solutions



IT6400 Series Bipolar
DC Power Supply / Battery Simulator



IT6000C Bidirectional
Programmable DC Power Supply



IT-M3600
Regenerative Power System



IT8200 Series
AC / DC Electronic Load



IT-M3200 High Precision
Programmable DC Power Supply



IT8500G+ Series
Programmable DC Electronic Load

Research / Education Solutions



IT6300 Series
Triple Channels DC power supply



IT6900 Series
Wide-range Programmable
DC Power Supply



IT-M3100D Ultra-compact
Wide Range DC Power Supply



IT8800 Series
High Power DC Electronic Load



IT6800A/B Dual-range
Programmable DC Power Supply



IT8400 High Performance
High Power DC Electronic Load



Get the latest information—Visit ITECH's website online

The screenshot displays the ITECH website interface. At the top, there is a navigation menu with links for Product, Solutions, Support, Download, Community, and Company. A prominent banner for the IT6000 series power supplies is featured, highlighting its output range (2250V/2040A/1152kW) and high power density (18kW in 3U size). Below the banner, there are icons for various product categories like DC Power Supply, AC Power Supply, and Electronic Load. On the right side, a 'Technical Support' section is highlighted with a red dashed box, containing a 'Product registration' form. The form includes fields for Phone, Mobile, Email, Address, Country, Serial number, and Model. A red dot and dashed line connect the 'Product registration' label to the form fields.

★ You can enjoy six-month extended warranty after registration within three months of purchase

The product overview provided in this catalog is for reference only; it is neither suggestions nor recommendation, and not a part of any contract. Due to the continual updating of our products, we reserve the right to change technical specifications and product specifications without notice. For more information, please feel free to visit www.itechate.com.



The logo for alldata, featuring a stylized bar chart with orange and blue bars above the word "alldata" in a bold, lowercase, sans-serif font. Below "alldata" is the text "EASTERN EUROPE" in a smaller, uppercase, sans-serif font.

www.alldataee.com



ITECH Web



ITECH Facebook



ITECH LinkedIn